



# GALaxy IV Traction Elevator Controller Manual

MAGNETEK M1000 AC DRIVE



A **VANTAGE** Company

GAL Manufacturing Corporation LLC  
50 East 153rd Street  
Bronx, NY 10451  
**Technical Support: 1-877-425-7778**

## **Foreword**

GAL Manufacturing has developed this manual with usability and safety in mind. General and specific safety notices and precautions are defined in the manual. However, GAL Manufacturing cannot be responsible for any injury to persons or damage to property (including the elevator equipment) resulting from negligence, misuse of the equipment, misinterpretation of instructions included in this manual, or due to any other cause beyond the control of GAL Manufacturing.

All drawings, illustrations, and information herein are the property of GAL Manufacturing and must not be made public or reproduced by any individual or entity other than the purchaser hereof without the express written permission of GAL Manufacturing.

# Table of Contents

---

<b>GALaxy IV Traction Elevator Controller Manual</b> .....	i
<b>Foreword</b> .....	ii
<b>Table of Contents</b> .....	iii
<b>Section 1 - Product Description</b> .....	1-1
1.1 Product Code Compliance .....	1-1
1.2 Specifications .....	1-1
1.3 Physical Layout of the Controller .....	1-1
1.3.1 Controller Top Cabinet .....	1-3
1.3.2 Controller Bottom Cabinet .....	1-5
1.4 Selector System .....	1-8
1.4.1 Tapeless Selector System .....	1-8
1.4.2 Absolute Position System (APS) Selector .....	1-9
1.4.3 Primary and Secondary Speed Feedback .....	1-10
1.5 Modes of Operation .....	1-10
1.5.1 General Operating Sequence .....	1-10
1.5.2 Reset Mode .....	1-11
1.5.3 Safety String Open Mode .....	1-11
1.5.4 Controller Inspection Mode .....	1-12
1.5.5 Car Top Inspection Mode .....	1-12
1.5.6 Access Mode .....	1-12
1.5.7 Independent Service Mode .....	1-12
1.5.8 Load Weighing Bypass Mode .....	1-13
1.5.9 Attendant Service Mode .....	1-13
1.5.10 Code Blue Hospital Service Mode .....	1-13
1.5.11 Fire Service Phase I Mode .....	1-13
1.5.12 Fire Service Phase I Alternate Return Mode .....	1-14
1.5.13 Fire Service Phase II Mode .....	1-14
1.5.14 Emergency Power Mode .....	1-15
1.5.15 Earthquake Mode .....	1-15
1.5.16 Stalled Mode .....	1-15
1.5.17 Automatic Mode .....	1-15
<b>Section 2 - Installation</b> .....	2-1
2.1 General Information .....	2-1
2.2 Selection of an Installation Site .....	2-1
2.3 Environmental Considerations for Installation .....	2-1
2.4 Wiring Guidelines and Instructions .....	2-2
2.4.1 Wiring Schematics .....	2-2
2.4.2 Proper Field Wiring .....	2-2
2.4.3 Ground Wiring .....	2-2
2.4.4 Hoistway Wiring .....	2-2
2.4.5 Elevator Car Wiring .....	2-3
2.4.6 Machine Room Wiring .....	2-3
2.5 Requirements for a Running Platform During Initial Startup .....	2-3
2.6 Normal and Emergency Terminal Slowdown Limits .....	2-3
2.6.1 Normal Terminal Slowdown Limits .....	2-3
2.6.2 Emergency Terminal Slowdown Limits .....	2-3
2.7 Directional Limit Switches .....	2-4
2.8 Final Limit Switches .....	2-5
2.9 Selector Installation .....	2-5
2.9.1 APS (Absolute Position System) Selector Installation .....	2-5
2.9.1.1 Installation of the Encoded Tape .....	2-5
2.9.1.2 APS Selector Floor Position Setup (Hoistway Learn) .....	2-16

2.9.1.3	Verify that the APS Selector is Installed Correctly and Communicating.....	2-16
2.9.1.4	Setting the APS Adjustable Variables .....	2-16
2.9.1.5	Zero the Hoistway .....	2-16
2.9.1.6	Setting Hoistway Floor Levels with APS Selector .....	2-18
2.9.2	Tapeless Selector Installation .....	2-20
2.9.2.1	Tapeless Selector 7 .....	2-20
2.9.2.2	Tapeless Selector 5 .....	2-26
<b>Section 3 - GALaxy Adjustment .....</b>		<b>3-1</b>
3.1	Procedure for Initial Power-up of Controller .....	3-1
3.1.1	Checking Main Line Voltage .....	3-1
3.1.2	Checking Controller Voltages .....	3-1
3.1.3	Verifying Operation of the Main CPU .....	3-2
3.2	Start-up Procedures .....	3-2
3.2.1	Requirements for a running platform during initial startup.....	3-2
3.2.2	Check Inspection Speed .....	3-9
3.2.3	Complete the Installation of Equipment .....	3-9
3.3	Adjustment Procedures .....	3-10
3.3.1	Verify Inspection Operation.....	3-10
3.3.2	Verify the Main CPU Velocity Feedback .....	3-11
3.3.3	Verify the Encoder Direction for the Main CPU .....	3-11
3.3.4	Match Feedback Velocity and Direction .....	3-11
3.3.5	Verify Safety Processor Velocity and Direction Feedback .....	3-12
3.3.6	Verify NTS Processor Velocity and Direction Feedback .....	3-12
3.3.7	Hoistway Learn Procedure.....	3-12
3.3.8	Adjust the Elevator.....	3-14
3.3.8.1	Automatic Run.....	3-14
3.3.8.2	Fine Tune the Ride Quality .....	3-14
3.3.8.3	Adjust the Stop.....	3-16
3.3.8.4	Adjust the Start.....	3-17
3.3.8.5	Load Weigher Setup .....	3-17
3.3.8.6	Empty Car Setup for Load Weigher .....	3-18
3.3.8.7	Full Load Setup for Load Weigher.....	3-18
3.3.8.8	Load Weigher Calibration Sequence.....	3-18
3.3.8.9	Adjust Load Weigher Pretorque .....	3-19
3.3.8.1	Adjust Position Lock.....	3-20
3.3.9	Adjust Safety Processor, NTS Processor, and Main CPU Limit Velocity Speed Clamps.....	3-20
3.3.9.1	Learn the Safety Processor, NTS Processor, and Main CPU Limit Velocity Speed Clamps.....	3-21
3.3.9.2	Manually Adjust the Safety Processor and NTS Processor Limit Velocity Speed Clamps .....	3-22
3.3.9.3	Manually Adjust the Main CPU's Limit Velocity Speed Clamps .....	3-23
3.3.9.4	Verify Inspection Velocity Clamp on Safety Processor.....	3-23
3.3.10	Reduced Stroke Buffer ETS Limits Setup.....	3-24
3.3.10.1	Manual Setup of ETS Limit Velocities .....	3-25
3.3.11	Verify Proper Operation of All Safety Circuits and Signal Devices .....	3-25
3.3.12	Perform Required Tests .....	3-25
<b>Section 4 - Troubleshooting .....</b>		<b>4-1</b>
4.1	General Information .....	4-1
4.2	Microprocessor CPU .....	4-1
4.3	Input / Output Boards.....	4-1
4.4	Run Sequence.....	4-2
4.5	The Safety Processor and Safety PAL.....	4-2
4.5.1	The CPU outputs that are controlled by the Safety PAL .....	4-3
4.5.2	The inputs monitored by the Safety Processor and Safety PAL.....	4-3
4.5.3	Outputs controlled by the Safety Processor.....	4-3
4.5.4	PIC and PAL Inhibit LEDs .....	4-5
4.5.5	MCU and COM LEDs.....	4-6
4.5.6	Troubleshooting Safety Processor and Safety PAL Faults .....	4-6

4.6	Fault Log .....	4-6
4.7	Main CPU Inputs and Outputs .....	4-7
4.8	Safety Processor Inputs and Outputs .....	4-15
4.9	NTS Processor Inputs and Outputs .....	4-16
4.11	APS Selector Inputs and Outputs .....	4-17
4.12	Relocate I/Os.....	4-18
4.13	GALileo Enhanced Diagnostics .....	4-18
4.13.1	GALileo Trace Screen.....	4-19
<b>Section 5 – LCD Interface .....</b>		<b>5-1</b>
5.1	Operating the LCD Interface .....	5-1
5.1.1	Interface Operator Panel .....	5-1
5.1.2	LCD Interface Main Menu .....	5-2
5.1.3	Elevator Status.....	5-2
5.1.4	Set Calls and Lockouts.....	5-3
5.1.5	Car Call Test .....	5-3
5.1.6	Inputs & Outputs .....	5-4
5.1.7	Job Statistics.....	5-4
5.1.8	Adjustable Variables.....	5-4
5.1.9	Car Timers .....	5-4
5.1.10	Date and Time .....	5-4
5.1.11	Diagnostics .....	5-5
5.1.12	Software Utilities .....	5-5
5.1.13	Power-Up Mode.....	5-6
5.1.14	Update / Verify Program .....	5-6
5.1.15	Select Video Display .....	5-6
5.1.16	Service Activation Timers.....	5-6
5.1.17	Display Hoistway Table.....	5-7
5.1.18	DZ & DZ Offset, Sel Cnt.....	5-7
5.1.19	FL & FL Offset Count.....	5-7
5.1.20	Reset Update Count Trig, Pulse Count Update Data .....	5-7
5.1.21	Elevator Setup .....	5-7
5.1.22	Match Feedback Velocity & Direction.....	5-7
5.1.23	Auto Learn Hoistway.....	5-8
5.1.24	Inspection Learn Hoistway .....	5-8
5.1.25	Learn Limit Velocities.....	5-8
5.1.26	Manually Setting Main CPU Speed Clamps .....	5-8
5.1.27	Inspection Open – Close Door .....	5-8
5.1.28	Lift Brake on Inspection .....	5-8
5.1.29	Loadweigher Setup.....	5-8
5.1.30	Load Weigher View/Modify .....	5-8
5.1.31	Calibrate Load Weigher .....	5-9
5.1.32	Counterweight & Buffer Test.....	5-9
5.1.33	Overspeed Test .....	5-9
5.1.34	Reset / View Faults .....	5-9
5.1.35	View Fault Log .....	5-9
5.1.36	Clear Fault Log .....	5-9
5.1.37	Reset Gripper Menu.....	5-9
5.2	LCD Menu Diagrams .....	5-10
5.2.1	Main Menu .....	5-10
5.2.2	Elevator Status.....	5-11
5.2.3	Set Calls and Lockouts.....	5-14
5.2.4	Car Call Test .....	5-15
5.2.5	Lockout Front Car Calls.....	5-16
5.2.6	Inputs and Outputs.....	5-17
5.2.7	Relocate I/Os .....	5-18
5.2.8	Add I/O Relocation .....	5-19

5.2.9	Job Statistics .....	5-20
5.2.10	Adjustable Variables .....	5-21
5.2.11	Car Timers .....	5-22
5.2.12	Date and Time .....	5-23
5.2.13	Diagnostics .....	5-24
5.2.14	View System Status Log .....	5-25
5.2.15	Group Comm Status .....	5-26
5.2.16	Group Can Comm Status .....	5-27
5.2.17	Car Can Comm Status .....	5-28
5.2.18	Machine Room Can Comm Status .....	5-29
5.2.19	Safety Can Comm Status .....	5-30
5.2.20	Drive Comm Status .....	5-31
5.2.21	APS CAN Comm Status .....	5-32
5.2.22	Software Utilities .....	5-33
5.2.23	Power-Up Mode .....	5-34
5.2.24	Power-Up Mode → Update / Verify Program .....	5-35
5.2.25	SD Card Read / Write Data .....	5-36
5.2.26	Network Card Setup .....	5-37
5.2.27	Preset Limit Velocities .....	5-38
5.2.28	Trace Setup .....	5-39
5.2.29	Send Floor Table to APS .....	5-40
5.2.30	Select Video Display .....	5-41
5.2.31	Service Activation Timer .....	5-42
5.2.32	Set Month/Day Timers .....	5-43
5.2.33	Clear Timers .....	5-44
5.2.34	Copy Day of Week Timers .....	5-45
5.2.35	View / Modify Timer Status .....	5-46
5.2.36	Set Timer Service .....	5-47
5.2.37	Set Day of Week Timers .....	5-48
5.2.38	Display/Modify Hoistway Tables .....	5-49
5.2.39	DZ & DZ Offset, Selector Count .....	5-50
5.2.40	FL & FL Offset Count .....	5-51
5.2.41	Reset Update Count, Pulse Count Update .....	5-52
5.2.42	Elevator Setup .....	5-53
5.2.43	Match Feedback Velocity & Direction .....	5-54
5.2.44	Learn Hoistway .....	5-55
5.2.45	Learn Limit Velocities .....	5-58
5.2.46	Open / Close Door .....	5-59
5.2.47	Lift Brake On Inspection .....	5-60
5.2.48	Load Weigher Setup .....	5-61
5.2.49	Car Buffer Test .....	5-64
5.2.50	Overspeed Test .....	5-65
5.2.51	Reset / View Faults .....	5-66
5.2.52	Reset Gripper / EBK Fault .....	5-67
<b>Section 6 – System Faults &amp; Detailed Faults .....</b>		<b>6-1</b>
6.1	System Faults .....	6-1
6.2	Detailed Faults Data and Description .....	6-132
6.2.1	Detailed Fault I/O Data Example .....	6-152
6.2.2	Detailed Fault I/O Data Form .....	6-155
<b>Section 7 – Adjustable Variables .....</b>		<b>7-1</b>
7.1	Main CPU Adjustable Variables .....	7-1
7.1.1	Car Motion Submenu .....	7-1
7.1.2	Car Brake Submenu .....	7-6
7.1.3	Modified Motion Submenu .....	7-10
7.1.4	Car Timers Submenu .....	7-12
7.1.5	Car Options Submenu .....	7-17

7.1.6	Service Options Submenu .....	7-25
7.1.7	Emergency Services Submenu .....	7-32
7.1.8	Group Dispatch Submenu .....	7-37
7.1.9	Group Options Submenu .....	7-42
7.1.10	CC & COP Lights Submenu .....	7-51
7.1.11	HC & IR Call Lights Submenu .....	7-59
7.1.12	CB, VIP HSec Hall Lights Submenu .....	7-67
7.1.13	System Options Submenu .....	7-72
7.2	Safety Processor Adjustable Variables .....	7-78
7.3	NTS Processor Adjustable Variables .....	7-82
7.4	APS Selector Adjustable Variables .....	7-86
<b>Section 8 – Appendix A .....</b>		<b>8-1</b>
8.1	Testing Precheck .....	8-1
8.2	Learn Limit Velocities .....	8-2
8.3	Emergency Terminal Speed Limiting Device .....	8-2
8.3.1	Testing ETSLD At The Bottom Terminal Landing .....	8-2
8.3.2	Testing ETSLD At The Top Terminal Landing .....	8-3
8.4	Emergency Terminal Stopping device .....	8-4
8.4.1	Testing ETSD At The Bottom Terminal Landing .....	8-4
8.4.2	Testing ETSD At The Top Terminal Landing .....	8-4
8.5	NTSD – Normal Terminal Stopping Device .....	8-4
8.5.1	Test The Top and Bottom Normal Limits .....	8-5
8.5.2	Testing NTSD At The Bottom Terminal Landing .....	8-5
8.5.3	Testing NTSD At The Top Terminal Landing .....	8-5
8.6	Ascending Car Overspeed .....	8-6
8.6.1	Test Ascending Car Overspeed From Governor Switch .....	8-6
8.6.2	Test Ascending Car Overspeed Stopping With Emergency Brake Only .....	8-7
8.6.3	Test Ascending Car Overspeed Detection From Main Processor .....	8-7
8.7	Unintended Movement .....	8-8
8.7.1	Test Unintended Movement .....	8-8
8.8	Speed Control on Inspection .....	8-8
8.8.1	Check Inspection Speed Limit .....	8-8
8.9	Speed Control on Access .....	8-9
8.9.1	Test Access Speed Limit .....	8-9
8.10	Speed in Leveling / Truck Zone .....	8-9
8.10.1	Test Leveling Speed Limit .....	8-9
8.11	Inner Landing Zone Limits .....	8-10
8.11.1	Test Inner Landing Zone Limits .....	8-10
8.12	Protection Against Traction Loss .....	8-10
8.12.1	Test Protection Against Traction Loss .....	8-10
8.13	Emergency Power .....	8-11
8.13.1	Test Emergency Power .....	8-11
8.13.2	Power Loss Brake Lift .....	8-11
8.13.3	Test MBC Contactor .....	8-11
8.13.4	Testing The Communication From The Controller To The UPS .....	8-11
8.13.5	Testing The UPS Battery Capacity .....	8-12
8.13.6	Procedure To Electrically Pick The Main And Emergency Brake .....	8-12
8.14	Buffer Test .....	8-12

# SYMBOLS USED IN THIS MANUAL



## CAUTION

This manual uses the CAUTION symbol to identify procedures and practices that may result in personal injury and/or equipment damage, if not followed correctly.



## DANGER

This manual uses the DANGER symbol as an alert to a danger of electrocution or an acute electrical shock. The DANGER symbol provides elevator personnel with a warning of severe personal injury or potential fatality that can result if safety precautions are not observed.



## NOTE / INFORMATION

In this manual, this symbol identifies information helpful to elevator personnel when carrying out a specific procedure or task.



## NOT APPLICABLE / DOES NOT EXIST

When this symbol appears inside a table, it indicates that a value or property is not defined, or is nonexistent, for the item listed.



# WARNINGS AND CAUTIONARY NOTES



Installation and wiring must be in accordance with the national electrical code, all local codes, and all elevator safety codes and standards. The 3-phase AC power supply to the equipment must originate from a properly fused disconnect or circuit breaker that is properly designed and sized for the specific controller requirements and the "Short Circuit Current Rating" listed on the controller. **Improper motor branch circuit protection will void warranty and may create a hazardous condition.**



Wiring to the controller terminals must be installed in a careful, neat manner. Stranded wire conductors must not have strands left out of the terminals. Leaving strands of wire out of the terminals can create a potential short circuit. All terminals and cable connectors must be seated properly. (See the **IMPORTANT** notice on the next page.)



Elevator control products must be installed by elevator personnel who have been trained in the construction, maintenance, repair, inspection, and testing of elevator equipment. The elevator personnel must comply with all applicable safety codes and standards. This equipment is an O. E. M. product designed and manufactured to comply with ASME A17.1-2016/CSA B44-16 Safety Code for Elevators and Escalators. It is the responsibility of the installer to ensure that the installation is performed safely and that the installation complies with all applicable codes.



Proper grounding is vitally important to the safe and successful operation of this system, and proper grounding should be installed to comply with all applicable codes. A separate ground wire should be installed from the building earth ground to the earth ground terminal in each controller. Proper conductor size must be utilized for grounding. In order to minimize resistance to ground, the shortest possible length should be used for the ground conductor.



Do not install the controller in a hazardous area where excessive vapors and chemical fumes are present. Do not install the controller in a dusty area. Do not install the controller in a carpeted area. The space in which the controller equipment is installed should be temperature controlled, moisture free, and should be maintained within a temperature range of 32° F and 110°F. The space in which the controller equipment is installed should be kept clean. The controller should be kept dry and should not be exposed to moisture or water condensation. Make sure the power supply voltage feeding the controller equipment does not fluctuate by more than +/- 10%.



Every safety precaution, whether or not specifically stated in this document, must be implemented when installing, adjusting, or servicing elevator equipment. All safety precautions must be followed to ensure the safety of elevator personnel and the general public.



Use only the correct rated fusing for controller protection. **Use of improperly rated fusing will void the warranty.**



# IMPORTANT NOTICE



Most of the field connections to GALaxy controls are made using stranded wire. When inserting this stranded wire into the terminals – especially those for EPD's (Electrical Protective Devices) – care must be taken to ensure that all the strands are properly inserted into the terminals. Improper stripping and insertion may leave strands outside of the terminals. Strands not properly inserted into the terminals may make contact with wires from an adjacent terminal.

The danger associated with an occurrence as described above has led GAL Manufacturing to recommend that, for all connections to the Electrical Protective Devices listed in ASME A17.1-2016/CSA B44-16, Requirements 2.26.2.1 through 2.26.2.39, elevator personnel must follow the guidelines listed below:

- Inspect all terminals used to connect Electrical Protective Devices. Ensure that the cage clamp is fully open before inserting a wire into the terminal block.
- Perform corrective action for wires with stray strands by one of the following methods:
  - Reconnect the wire with all wire strands correctly installed into the terminal. Visually verify that **no wire** strands are outside of the terminal. The conductor should be stripped and inserted completely into the terminal in such a manner that no more than two millimeters of bare wire is visible; or
  - Attach a ferrule to the end of field wire for safety devices (as pictured below in Figures 0-1 and 0-2) and insert the ferrule into the terminal; or
  - Use an acceptable method such as tinning.
- After removal and replacement of any of these field wires, the actual Electrical Protective Device should be checked for proper operation.



**Figure 0-1**  
**Crimp Tool for Ferrule**



**Figure 0-2**  
**Stranded Wire with Ferrule Attached**

## Section 1 - Product Description

---

The GALaxy IV Traction Elevator Controller is a computer-based system offering superior performance, flexibility, and reliability. The controller is designed for quick installation and ease of troubleshooting. **It is extremely important for elevator personnel to become familiar with the procedures in this manual.** The manual provides a detailed reference for controller installation, and elevator personnel should read it thoroughly before attempting to install the equipment.

### 1.1 Product Code Compliance

---

- CSA B44.1-14/ASME A17.5-2014
- ASME A17.1-2016/CSA B44-16

### 1.2 Specifications

---

#### Standard Features:

- Inspection Operation (Car Top & Controller)
- Access Operation
- Independent Service
- Fire Service Phase I
- Fire Service Phase I Alternate Return
- Fire Service Phase II
- Emergency Power
- Earthquake Service
- Onboard Diagnostics LEDs
- Onboard LCD Interface
- Motor Protection Timers
- Door Motor Protection Timer
- Field Adjustable Parameters
- Elevator Duty Rated NEMA Motor
- GALileo Enhanced Diagnostics

#### Environment:

- 32°F to 110°F Ambient Temperature
- 12,000 Feet Maximum Altitude
- 95% Maximum Humidity

#### Optional Features:

- Selective Rear Doors
- Attendant Service
- Code Blue Hospital Service
- Security
- Remote Diagnostics
- Emergency Power

### 1.3 Physical Layout of the Controller

---

Figure 1-1 shows the general layout of the GALaxy IV Traction Elevator Controller. The control boards, including the Main CPU, are housed in the top cabinet. The bottom cabinet houses the solid-state drive and the power connections. The dynamic braking resistor enclosure is located to the left of the top cabinet.



Figure 1-1: General Layout of the Controller

### 1.3.1 Controller Top Cabinet

---

Figure 1-2 shows a typical layout of the components inside the top cabinet. These components are listed below.

- 1) **Main I/O Board:** The 1102 Main Control Board contains input and output devices, controller switches, fuses and field wiring terminal connections. The Main I/O Board also includes the Safety Processor, the Safety PAL, and the NTS Processor.
- 2) **Main CPU Board:** The 1100 CPU Board is a dual core 32-bit CPU. It executes the main control system programs. The main core runs the car operation and the secondary core runs the group operation.
- 3) **LCD Interface:** The 1005 LCD Interface Board or the 1101 LCD/VGA Interface Board provides a user interface to all controller adjustments, adjustable parameters, and diagnostic information.
- 4) **Power Supply Board:** This board provides power to the controller CPU and its peripheral boards. It is a 5 Volt DC regulated power supply rated at 6 Amps with over-voltage and short circuit protection.
- 5) **PI Driver Board:** This board is the driver for CE or E-Motive Position Indicator Displays.
- 6) **Main Brake Power Board:** This board provides DC power for the Main Brake Relay Board.
- 7) **Main Brake Relay Board:** This board includes the Run and the Brake contactors which provide two electro-mechanical devices to remove power from the main brake.
- 8) **Emergency Brake Relay Board:** This board includes the Run and the Brake contactors which provide two electro-mechanical devices to remove power from the emergency brake.
- 9) **Emergency Brake Power Board:** This board provides DC power for the Emergency Brake Relay Board.
- 10) **Group I/O Side Panel:** This is a side panel providing mounting space for group operation I/O. The group I/O panel can be removed and placed in any car or a separate enclosure.
- 11) **Car I/O Side Panel:** This is a side panel providing mounting space for additional car I/O.
- 12) **I/O Board:** This is a typical I/O expansion board that provides input/output interface to elevator buttons, switches, lights, and other devices. The board may use either 24VAC, 120VAC, or 24VDC, depending on device requirements.
- 13) **Dynamic Braking Resistor:** When the controller is equipped with dynamic braking resistors, these resistors are mounted in the louvered cabinet attached to the side of the top cabinet.

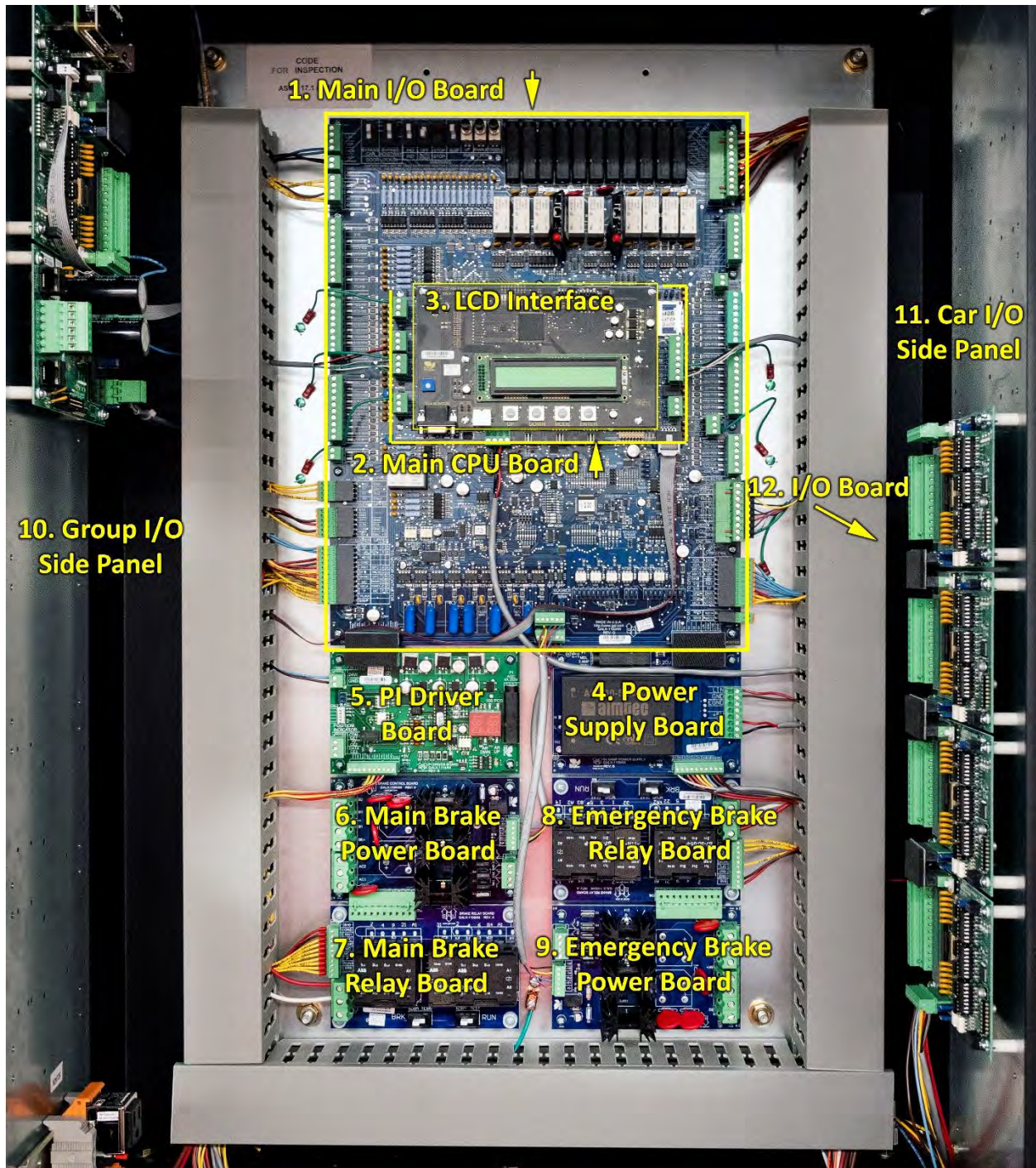

Figure 1-2: Typical Layout of the Controller Top Cabinet

### 1.3.2 Controller Bottom Cabinet

---

Figure 1-3 shows the typical layout of the components in the bottom cabinet. These components are listed below.

- 1) **System Transformer:** The System Transformer transforms the line voltage to 230 VAC, 115 VAC, and 24 VAC for the low voltage signals and other controller functions.
- 2) **Brake Transformer:** The brake transformer transforms the line voltage to 145 VAC or 290 VAC to allow a closer match to the DC Brake voltage. This transformer is used when the line voltage is above 208 VAC.
- 3) **Power Terminal Block:** This terminal block provides the connection terminals for line power input wiring and motor power wiring.
- 4) **Line Filter:** The line filter prevents high frequency noise from returning to the line power.
- 5) **AC Filter:** This component filters high frequency noise from 115 VAC Controller power.
- 6) **Circuit Breakers:** Circuit breakers for L1, L2, BK1, BK2 and BK3 controller power.
- 7) **Signal Terminal Block:** This terminal block provides interconnection terminals for the earth ground and other signal wires to the top controller box.
- 8) **Drive:** Main drive unit.
- 9) **Motor Contactors:** DC or AC rated motor contactor sized for each specific job.
- 10) **Regen:** When the controller is equipped with a regenerative drive this regen is mounted in the bottom cabinet.

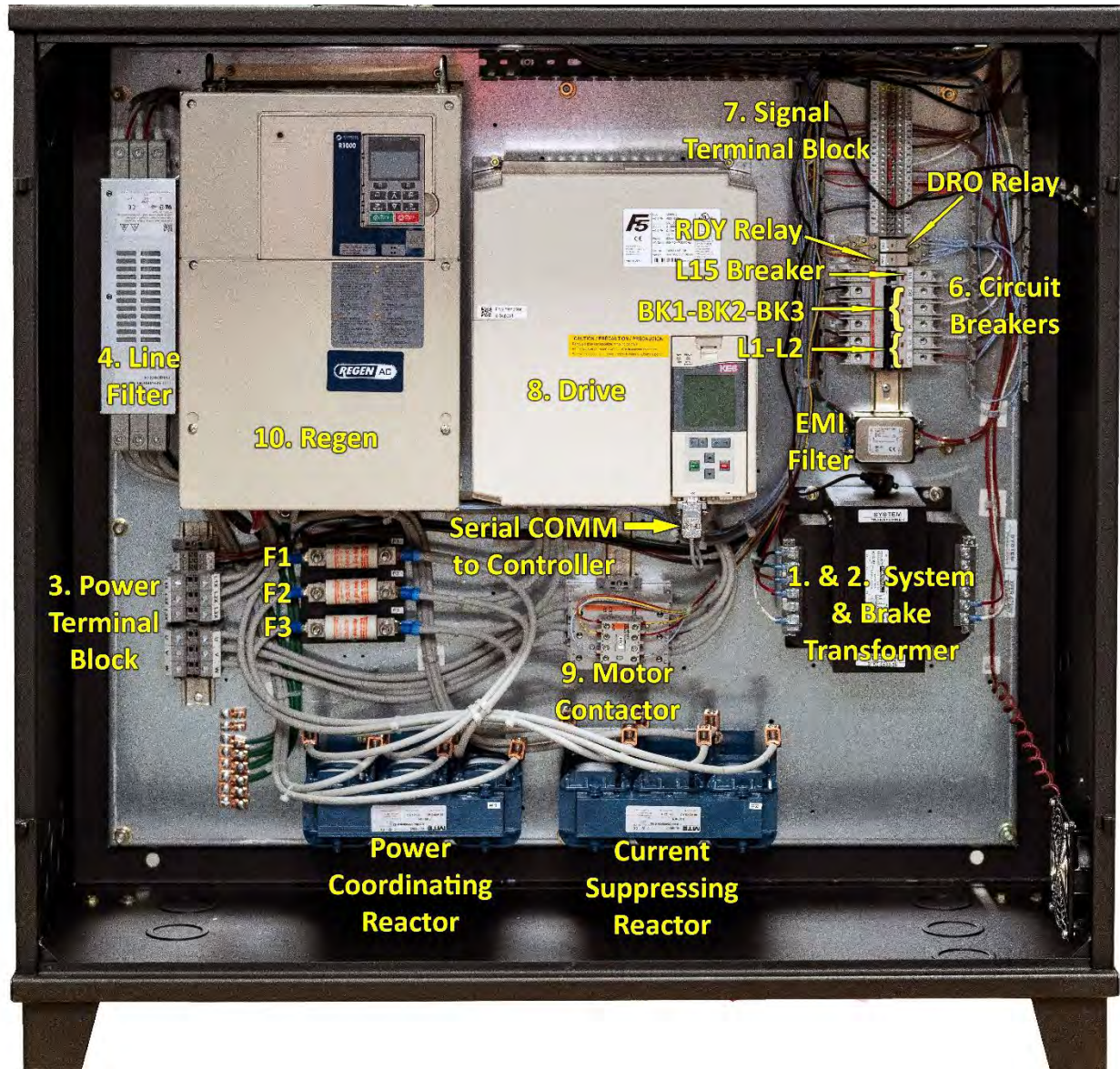

Figure 1-3: Typical Layout of the Controller Bottom Cabinet





Figure 1-4: Magnetek M1000 AC Drive Mounted in Bottom Cabinet

## 1.4 Selector System

The selector system for the GALaxy controller can be a tapeless system or an Absolute Position System with an encoded touchless tape.

### 1.4.1 Tapeless Selector System

The tapeless “selector 7” system uses an absolute encoder mounted on the governor and a selector mounted on top of the car. The selector on top of the car is comprised of a selector “door zone” unit and a selector “terminal slowdown” unit. The terminal slowdown magnets are mounted on the rail with a specially designed rail bracket. The rail bracket is pre-drilled so that the alignment of the slowdown magnets matches the alignment of the sensors on the selector “terminal slowdown” unit. The selector “door zone” unit is used for exact floor position when stopping and re-leveling the car. The sensors on the selector “door zone” unit are activated by 8” floor magnets placed at each floor. These 8” floor magnets are placed directly on the rail and do not require rail brackets. The absolute encoder uses a CAN Open serial protocol to send an accurate position that is used for the primary speed feedback and position of the car. The encoder is coupled to a rotating shaft on the governor. If the governor on the job does not have a rotating shaft, it must be replaced with one that does.

The tapeless “selector 5” is similar to the tapeless “selector 7”. However, the door zone and terminal slowdown sensors in the tapeless “selector 5” are mounted in one unit on the car top. The tapeless “selector 5” requires brackets for the door zone magnets at each floor.

A block diagram of the tapeless selector system is shown in Figure 1-6.

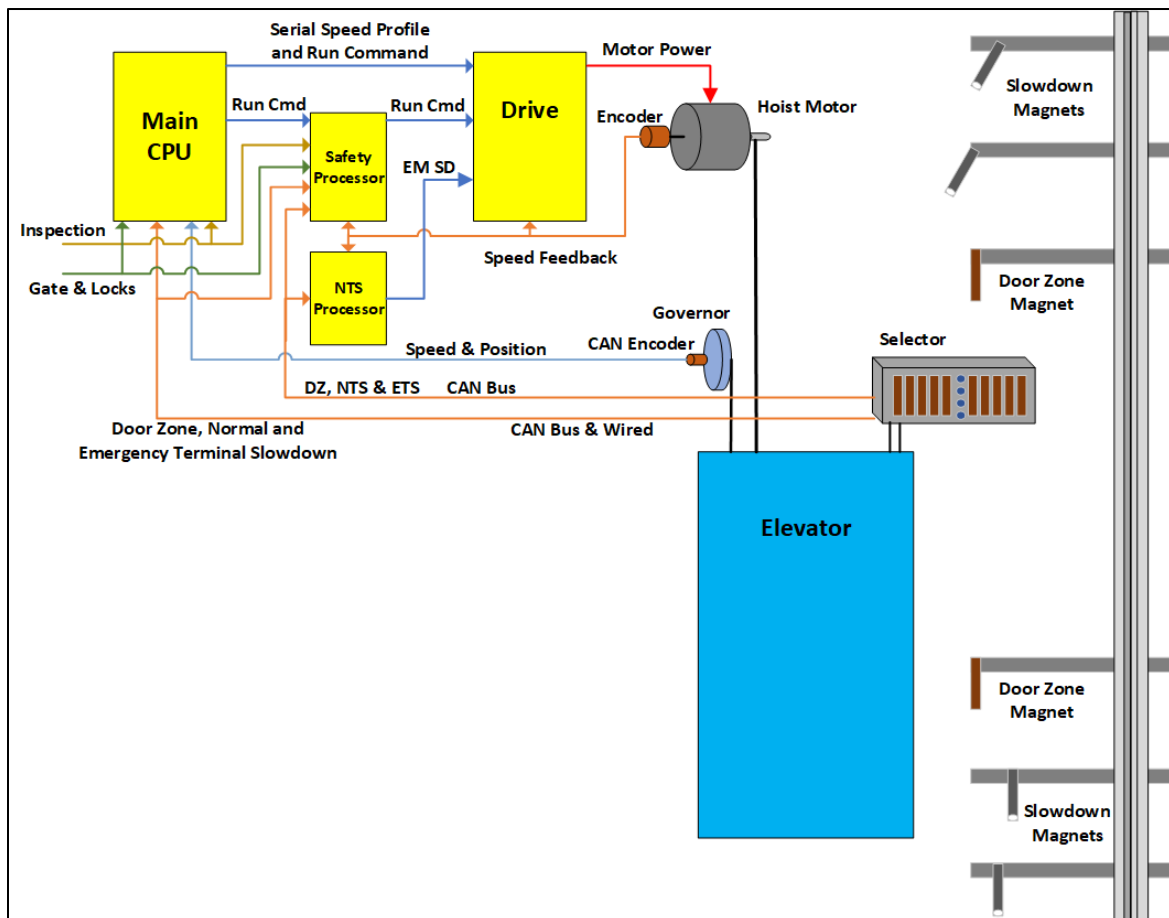

Figure 1-6: Traction Control System with a Tapeless Selector

### 1.4.2 Absolute Position System (APS) Selector

The Absolute Position System Selector uses an encoded tape that is read by two independent cameras. The device is SIL3 rated to supply position and velocity data over two independent CAN bus channels. The selector interface has two independent microprocessors, Processor 1 and Processor 2, that learn and record the hoistway data independent of the Main CPU. These two processors provide redundant DZ, UN and DN outputs. Processor 2 also provides the NTS processor with velocity and slowdown input positions. The APS Processor 1 uses the upper camera and CAN channel A. The APS Processor 2 uses the lower camera and CAN channel B.

The ETS limits are magnetic switches mounted to the APS selector and are actuated by magnets mounted to rail brackets. A block diagram of the Absolute Position System is shown in Figure 1-7.

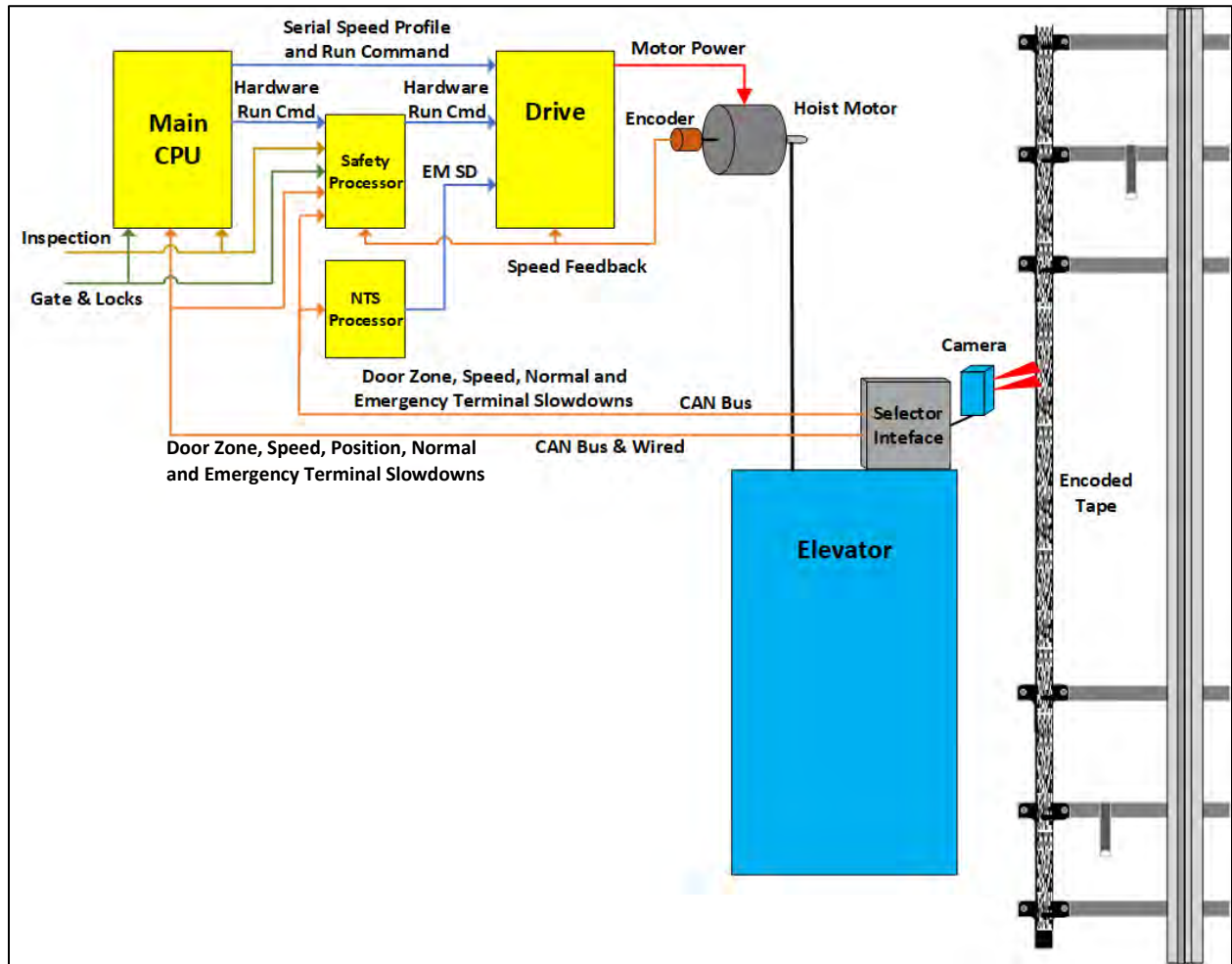

Figure 1-7: Traction Control System with an APS Selector

### 1.4.3 Primary and Secondary Speed Feedback

---

On the CAN open tapeless system, the Main CPU receives position feedback from the CAN encoder mounted on the governor and calculates the primary velocity feedback from the change in position. The resolution of the tapeless selector system can be adjusted (Car Motion Sub Menu: Encoder PPR). It is recommended to adjust the system to provide a resolution of approximately 0.005 inches or 200 pulses per inch. The NTS processor and the Safety Processor receive pulses from the machine mounted encoder to calculate a secondary velocity.

On the APS Selector system, the encoded tape and the upper camera are utilized to provide the primary position and velocity feedback to the Main CPU through CAN channel A. The APS selector system provides 0.5mm resolution or 50.8 pulses per inch. The NTS processor receives information from the encoded tape and the lower camera through CAN channel B to calculate a secondary velocity feedback. The Safety Processor receives pulses from the machine mounted encoder to calculate a third velocity feedback.

With all selector systems, the Safety Processor uses velocity feedback to verify that the car is traveling at a safe speed when the Emergency Terminal Stopping Device limits are activated, when the car doors are open, and when running on inspection. If the Safety Processor detects a velocity limit error, it will immediately turn off the PIC enable output and drop the SFC relay to remove power from the driving machine and brake. The NTS processor uses velocity feedback to verify that the car is traveling at a safe speed when the Normal Terminal Stopping Device limits are activated. If the NTS Processor detects a velocity limit error, it will turn off the NTS outputs to the drive causing the drive to initiate a timed slowdown.

## 1.5 Modes of Operation

---

### 1.5.1 General Operating Sequence

---

Normal elevator operation, Automatic Mode, is selective-collective. When the elevator is traveling upwards to answer calls, all up hall calls at floors above the car are answered in the order as the car travels up, regardless of the order in which the calls were registered. Upon reaching each landing with a car call or hall call registered, the car and hall doors at that floor are automatically opened.

The doors stay open for a dwell time that is field adjustable. There are three different dwell times depending on whether it is a lobby call, car call, or hall call. The door will close before the set dwell time has elapsed if a passenger presses the door close button. The door will reopen before it is fully closed if the door open button is pressed, if a passenger pushes on the safety edge, if the photo-eye light beam is interrupted, if a hall call for that floor in the direction of travel is registered, or if the car call for that floor is registered. The door will close when the door opening condition is eliminated. When the door has fully closed, the calls are answered.

When all up hall calls and car calls above the car have been answered, the elevator reverses direction and travels downward to answer car calls and down hall calls placed below the car. The calls are answered as previously described for up calls. When all calls below a down car are answered, the car reverses direction to repeat the cycle. In short, an elevator traveling up will bypass down hall calls, and an elevator traveling down will bypass up hall calls.

In buildings with more than one elevator grouped together, the actual time of arrival, “real time”, is used to estimate how long each elevator will take to answer a hall call. The elevator that can respond the fastest takes the call. Real time-based dispatching permits the controllers to quickly respond to actual demand for elevator service. Some of the criteria used to estimate the time of arrival are listed below.

- Actual elevator floor to floor run times
- Actual run time to the floor whether it is a multi-floor run or a one floor run

- Whether the elevator is in or out of service
- Whether the elevator is in load weigh bypass mode
- The direction and position of each elevator in the group
- The average door cycle time at each stop
- Status of each elevator, accelerating, full speed, decelerating, actual time in motion
- Number of stops required due to car calls
- Number of stops required due to previously assigned hall calls
- System demand

The above performance criteria are continuously measured and stored for improved accuracy in the dispatching algorithm. All of the above data is continuously scanned, and the hall calls are reassigned if the conditions change and another car can respond faster. The ability to measure actual hall waiting time virtually eliminates long wait times and improves the average hall call waiting intervals throughout the building.

### 1.5.2 Reset Mode

---

Reset mode is initiated when the elevator power is first turned on, or when the system is reset. When the reset mode is initiated, the controller program is automatically loaded, and internal tests are run to ensure that both the car and controller are electrically operational before putting the car into service. The car will not move until reset mode is completed. Some of the internal tests that the controller performs are listed below.

- Is the safety string made up?
- Is the elevator on inspection?
- Is the door close limit open?
- Are the interlocks in the closed state?
- Is the Hoistway position correct?

If all the safeties are made up, and the elevator is on automatic operation, and it is at floor level, the elevator will go into automatic mode. If the elevator is not at floor level, it will run slow speed down to the nearest floor, level into the floor, and reset the floor position count.

### 1.5.3 Safety String Open Mode

---

Safety string open mode is initiated when a safety is open. Some of the safety string devices are listed below:

- Governor Overspeed Switch
- Top Final Limit
- Bottom Final Limit
- Pit Switch
- Emergency Exit Switch
- Safety Operated Switch
- Car Top Stop Switch
- Firefighters' Stop Switch
- In Car Stop Switch
- Controller Stop Switch
- Rope Gripper Contact
- Drive Ready Relay (SFD)

When the safety string is made back up, the elevator will go back to reset mode.

#### 1.5.4 Controller Inspection Mode

---

The controller inspection mode is initiated by placing the “INSP” switch on the 1102 board in the inspection position (down). Controller inspection mode permits operation of the car from the machine room. This mode performs the following operations:

- Enables the controller inspection “ENABLE”, “UP” and “DOWN” push buttons
- Door locks are active and must be closed to move the car.
- Pressing the controller “ENABLE” and “UP” pushbuttons causes the-elevator to move at inspection speed in the up direction.
- Pressing the controller “ENABLE” and “DOWN” pushbuttons causes the elevator to move at inspection speed in the down direction.

#### 1.5.5 Car Top Inspection Mode

---

This inspection mode is initiated by placing the inspection switch on top of the car in the inspection position. Inspection mode permits operation of the car from the car top inspection station. This mode performs the following operations:

- Disables access top and access bottom hall switches.
- Disables the controller "ENABLE", "UP" and "DOWN" push buttons.
- Door locks are active and must be closed to move the car.
- Enables the car top inspection station "SAFE", "UP" and "DOWN" push buttons
- Pressing the inspection station "UP" and "SAFE" pushbuttons causes the elevator to move at inspection speed in the up direction.
- Pressing the inspection station "DOWN" and "SAFE" pushbuttons causes the elevator to move at inspection speed in the down direction.

#### 1.5.6 Access Mode

---

The access mode is initiated by placing the key operated access switch located in the car operating panel to the on position. Access mode allows entrance into the hoistway by qualified and authorized elevator personnel for equipment inspection and service. Access to the top of the car is possible from the top landing, and access to the pit is possible from the bottom landing. Enabling this mode permits the following operation:

- Enables the access key switches at the top and bottom landing in the entrance door jambs.
- Bypasses the gate switch to allow car movement with the car door open.
- Bypasses the top or bottom landing hall door lock, depending on which terminal access switch is being actuated.
- Turning the access key switch to the up position causes the elevator to move at access speed in the up direction.
- Turning the access key switch to the down position causes the elevator to move at access speed in the down direction.

#### 1.5.7 Independent Service Mode

---

The independent service mode is initiated by placing the key operated independent switch located in the car operating panel to the on position, or by placing the controller toggle switch “IND” to the down position. Independent mode permits operation of the car with an operator. This mode performs the following operations:

- Hall initiated calls are ignored.
- Hall lanterns and gongs are disabled.
- The doors open automatically and stay open until closed by the operator.

- Closing the doors requires constant pressure on the door close button.
- When the car door is closed, the car answers the nearest registered car call in the direction of travel.

### 1.5.8 Load Weighing Bypass Mode

---

The load weighing bypass mode is initiated when the car is loaded to a predetermined percentage of full capacity, by closing a connection between terminals “LC” and “LW”, or from serial communication from a load weighing device. Load weigh bypass mode allows the car to answer car calls and lighten the load before answering any more hall calls. This mode performs the following operations:

- Hall initiated calls are ignored.
- All other elevator functions operate as if on full automatic service.

### 1.5.9 Attendant Service Mode

---

The attendant service mode is initiated by placing the key operated attendant switch located in the car operating panel to the on position. Attendant mode permits operation of the car with an attendant. This mode performs the following operations:

- The doors open automatically and stay open until closed by the attendant.
- Closing the doors requires a momentary pressure on the door close button, or the up or down buttons located in the car operating panel.
- Hall initiated calls are answered unless there is constant pressure on the bypass button.
- Hall lanterns and gongs are enabled.
- The direction of preference can be specified by momentary pressure on the up or down buttons located in the car operating panel.

### 1.5.10 Code Blue Hospital Service Mode

---

Code blue hospital service mode is initiated by turning one of the code blue switches, located at each floor where medical emergency service is required, to the on position. A car is selected to respond to the code blue call. That car will perform the following:

- Cancel all car calls
- Any hall calls previously assigned will be transferred to another car.
- If traveling toward the code blue call, it will proceed nonstop to the code blue call floor.
- If traveling away from the code blue call, it will slow down and stop at the nearest floor, maintain doors closed, reverse direction and proceed nonstop to the code blue call floor.
- If at a floor other than the code blue call floor, the elevator will close the doors and proceed nonstop to the code blue call floor.
- Once at the code blue call floor, the doors will open and remain open.
- The code blue in car switch located in the car operating panel must then be turned to the on position. If the code blue in car switch is not turned to the on position within 60 seconds from the time the doors reach full open on the code blue call floor, the car will revert back to normal operation.
- Upon activation of the key switch, it will allow the car to accept a car call for any floor, close the doors, and proceed nonstop to the floor desired.
- The return of the code blue in car key switch to the normal position will restore the car to normal service.

### 1.5.11 Fire Service Phase I Mode

---

Fire service phase I is initiated when the primary smoke sensor is activated, or the fire key switch located in the hall station on the primary return floor is turned to the on position. The primary return floor is usually

the lobby floor, but could be another landing, if it better serves the needs of emergency personnel when fighting a fire or performing rescues. When fire service phase I is enabled:

- The fire emergency return light illuminates and the fire buzzer sounds.
- The emergency stop switch is disabled when the door closes.
- The car travels to the primary return floor without answering any calls, then parks with the door open. The fire buzzer turns off, but the fire emergency return light stays illuminated.
- If the car is at a landing with the doors open, the doors will close, and the car will return non-stop to the primary return floor.
- If the car is traveling away from the primary return floor, the car will stop at the next landing, the doors will not open, and the car proceeds immediately to the primary return floor.
- Turning the fire service key switch to the bypass position will restore the elevator to normal service.
- The elevator will perform per ASME A17.1 requirement 2.27.3 unless otherwise specified.

### 1.5.12 Fire Service Phase I Alternate Return Mode

---

Fire service phase I alternate return is initiated when the smoke sensor in front of the elevator at the primary return floor is activated. When fire service phase I alternate return is enabled:

- The fire emergency return light illuminates and the fire buzzer sounds.
- The emergency stop switch is disabled when the door closes.
- The car travels to the alternate return floor without answering any calls, then parks with the door open. The fire buzzer turns off, but the fire emergency return light stays illuminated.
- If the car is at a landing with the doors open, the doors will close, and the car will return nonstop to the alternate return floor.
- If the car is traveling away from the alternate return floor, the car will stop at the next landing, the doors will not open, and the car proceeds immediately to the alternate return floor.
- Turning the fire service key switch to the bypass position will restore the elevator to normal service.
- The elevator will perform per ASME A17.1 requirement 2.27.3 unless otherwise specified.

### 1.5.13 Fire Service Phase II Mode

---

To initiate fire service phase II, the car must first have been placed in fire service phase I and, as a result, be parked at the designated level with the door fully open. Following this, the key operated fire service phase II switch, located in the car operating panel must be placed in the on position. Fire service phase II permits operation of the car by a fire fighter. This mode performs operations in accordance with ASME A17.1 requirement 2.27.3 as follows:

- The doors open only with constant pressure on the door open button, after they have been fully closed.
- The doors close only with constant pressure on the door close button, after they have been fully opened.
- Hall lanterns and gongs are disabled. Safety edge and electric eye are disabled.
- All registered car calls can be canceled with momentary pressure on the call cancel button located in the car operating panel.
- All hall calls are disabled.
- To remove the car from fire service phase II the car must be at the fire return landing with the doors in the fully open position and the phase II switch turned to the off position.
- See ASME A17.1 requirement 2.27.3 for specific operation of fire service phase II.



### 1.5.14 Emergency Power Mode

---

Emergency power mode is initiated when a connection is made between terminals “FEP” and “EMP”. This mode performs the following operations:

- All cars are returned to the bottom floor one at a time and remain there with their doors open.
- If a car is selected to run it will go back into normal operation.
- Removing the connection between terminals “FEP” and “EMP” will remove the cars from emergency power operation.

### 1.5.15 Earthquake Mode

---

Earthquake mode is initiated upon activation of a seismic switch or counterweight derailment switch. This mode performs the following operations:

- If in motion, and the seismic switch is activated, the car will decelerate into slow speed, proceed to the nearest available floor, open the doors and shut down.
- If in motion, and the counterweight derailment switch is activated, and the car is moving away from the counterweight, then the car will decelerate into slow speed, and proceed to the nearest available floor, open the doors and shut down.
- If in motion, and the counterweight derailment switch is activated, and the car is moving toward the counterweight, then the car will perform an emergency stop, then move at slow speed away from the counterweight to the nearest available floor. After stopping at the nearest floor, the doors will open, and the car will shut down.

### 1.5.16 Stalled Mode

---

Stalled mode is initiated when the elevator has been in run mode longer than the field adjustable anti-stall timer. This mode performs the following operations:

- Shuts down the elevator.
- Does not allow the elevator to restart until elevator is put on inspection or main line switch is cycled.
- The door open button remains active.

### 1.5.17 Automatic Mode

---

Since this is the normal operating mode, the controller automatically enters this mode if none of the previously described modes are activated, and if no fault is detected. The following operations are performed in automatic mode:

- The car operates in selective-collective control sequence when answering calls.
- Hall calls and car calls are functional.
- Hall lanterns and gongs are operational.
- Simplex Cars Park at the last call answered unless simplex lobby parking has been enabled in the program. In a multi-car group, a car is always parked at the lobby if no other demand exists.
- The doors remain closed when the car is parked.

## Section 2 - Installation

---

### 2.1 General Information

---

This section provides basic guidelines and recommendations for the proper installation of the controller equipment. These guidelines should be used as general instructions. They are not intended to usurp local codes and regulations.

### 2.2 Selection of an Installation Site

---

There are several factors that elevator personnel should consider when choosing a location for installing this product. The elevator controller should be installed at a location that provides the most convenient access for adjustment, inspections, and repairs. If at all possible, elevator personnel should have an unobstructed view of the machine when standing in front of the controller. A safe and adequate workspace around the controller must be provided. Work areas must be free of any items that might interfere with the proper routing of conduits or hinder the opening of cabinet doors. All clearances, workspaces, lighting, and guarding around the controller must comply with governing codes.

### 2.3 Environmental Considerations for Installation

---

The controller package is provided with a standard type 1 enclosure. This type of controller should be installed in a clean, dry, and non-corrosive environment. Ideally, the equipment room should be temperature controlled between 70° F and 90° F. However, control equipment will function properly within an ambient temperature range of 32° to 110° F. If temperatures remain at the upper and lower extremes of this range for an extended period of time, the life expectancy of the control equipment may be reduced. It is important to always keep the controller dry, clean, and free of any dust and debris.

The control system is designed to have a high immunity to electrical noise, radio frequency radiation, and magnetic interference. However, high levels of these items could cause interference with certain parts of the control system.

The power supply feeding the controller should have a fluctuation of no greater than + or - 10%.

## 2.4 Wiring Guidelines and Instructions

---



See the **IMPORTANT NOTICE** on page “x” of this manual

### 2.4.1 Wiring Schematics

---

A complete set of wiring schematics and connection diagrams will be provided for each job. Each set of wiring schematics and connection diagrams are job specific. The job name and number will be listed in the bottom right corner of each page of these documents.

### 2.4.2 Proper Field Wiring

---

Most of the field connections to GALaxy controls are made using stranded wire. When inserting this stranded wire into the terminals – especially those for EPD’s (Electrical Protective Devices) – care must be taken to ensure that all the strands are properly inserted into the terminals. Improper stripping and insertion may leave strands outside of the terminals. Strands not properly inserted into the terminals may make contact with wires from an adjacent terminal.

The danger associated with an occurrence as described above has led GAL Manufacturing to recommend that, for all connections to the Electrical Protective Devices listed in ASME A17.1-2016/CSA B44-16, Requirements 2.26.2.1 through 2.26.2.39, elevator personnel must follow the guidelines listed below:

- Inspect all terminals used to connect Electrical Protective Devices. Ensure that the cage clamp is fully open before inserting a wire into the terminal block.
- Perform corrective action for wires with stray strands by one of the following methods:
  - Reconnect the wire with all wire strands correctly installed into the terminal. Visually verify that **no wire** strands are outside of the terminal. The conductor should be stripped and inserted completely into the terminal in such a manner that no more than two millimeters of bare wire is visible; or
  - Attach a ferrule to the end of field wire for safety devices (as pictured in Figures 0-1 and 0-2) and insert the ferrule into the terminal; or
  - Use an acceptable method such as tinning.
- After removal and replacement of any of these field wires, the actual Electrical Protective Device should be checked for proper operation.

### 2.4.3 Ground Wiring

---

Proper grounding of the power supply, controller, elevator car, and hoistway is required. Separate conductors should be run for EG (earth ground) and GND terminals. These terminals and conductors are detailed on the wiring schematics.

### 2.4.4 Hoistway Wiring

---

All hoistway wiring is detailed on the wiring schematics and connection diagrams. The number of required hoistway conductors is listed in the connection diagrams. A job specific “pull sheet” is also included in the connection diagrams.

### 2.4.5 Elevator Car Wiring

---

All elevator car wiring is detailed on the wiring schematics and connection diagrams including the wiring to the car station, door operator, car top selector, and inspection station. The number of required traveling cable conductors is listed in the connection diagrams. A job specific “pull sheet” is also included in the connection diagrams.

### 2.4.6 Machine Room Wiring

---

All machine room wiring is detailed on the wiring schematics and connection diagrams including the main power supply wiring, motor wiring, brake wiring (traction only), and field wiring.

## 2.5 Requirements for a Running Platform During Initial Startup

---

The GALaxy IV Quickstart provides the requirements for a running platform during initial startup. There is a specific GALaxy IV Quickstart for each drive and machine type. The instructions and procedures in the GALaxy IV Quickstart should be used to provide a running platform during initial startup. The “Start-up Procedures” are also described in section 3.2 of this manual.

## 2.6 Normal and Emergency Terminal Slowdown Limits

---

There are two sets of slowdown switches used, the Normal Terminal Slowdown Limits (including UN/DN, UT1/DT1, UT2/DT2, UT3/DT3, etc.) and Emergency Terminal Slowdown Limits (including UTS, DTS and ETS top and bottom). Note that the Normal Terminal Slowdown Limits are not considered part of an electrical protective device and can be read from an encoded tape instead of using physical switches.

### 2.6.1 Normal Terminal Slowdown Limits

---

The Normal Terminal Limits are used to cause the car to slowdown and stop at or near the terminal landing if the car actuates the limit at a speed higher than the setup speed for that limit. The NTS processor monitors the speed of the car, independently of the Main CPU. When the limits are actuated, if the speed is too high, the NTS Processor will turn off an output to the drive to cause the drive to initiate a timed emergency slowdown. In addition, software on the Main CPU, that is running independently to the speed profile software, will clamp the speed command to the drive at the preset clamp velocity of each normal terminal slowdown limit.

### 2.6.2 Emergency Terminal Slowdown Limits

---

The Emergency Terminal Slowdown limits are used to prevent the car from striking the buffer at a speed greater than the rated buffer striking speed and to also slow down and stop the car if the Normal Terminal Slowdown devices do not slow down the car.

UTS and DTS emergency slowdown limit switches are used on all traction cars as the emergency terminal stopping device. On cars with reduced stroke buffers an ETS limit is used as a verification limit at both the top and bottom of the hoistway for redundancy. The Safety Processor monitors these switches as the slowdown speed verification points. If the car actuates the limit at a speed greater than the preset speed parameter, power is immediately removed from the motor and brake for an emergency stop independent of the main CPU. UTS and DTS limits are used on all traction controllers as a secondary check to verify the car’s preset position when the car is at floor level at the top or bottom landing.

The distance that the limits are placed from the terminal landing depends on the speed of the car. Table 2-1 shows the recommended slowdown limit distances based on the contract speed of the car. The distances listed represent the distance from the terminal landing when the slowdown switch is actuated. All distances are shown in inches. When using the Absolute Position System (APS) selector, the slowdown limit positions are automatically calculated by the GALX-1133 selector interface board. If the calculated slowdown values are not adequate, the distances can be modified from the LCD Interface under the “APS Selector Adj Var” menu.

 The distances listed in Table 2-1 are recommended “initial” values. These distances may need to be changed during the final adjustment procedures.

FPM	UT/ DT	UT1/ DT1	UT2/ DT2	UT3/ DT3	UT4/ DT4	UT5/ DT5	UT6/ DT6	UTS/ DTS	UTS/ DTS/ETS (Reduced Stroke buffer)
50	5"							4"	4"
75	9"							7"	7"
100	12"							10"	10"
150	21"							17"	17"
200	30"							22"	22"
250	45"							32"	32"
300	25"	50"						37"	37"
350	33"	65"						48"	48"
400	41"	83"						60"	60"
450	51"	102"						74"	74"
500	56"	113"						83"	83"
600	52"	105"	157"					114"	114"
700	70"	140"	209"					151"	151"
800	67"	135"	202"	269"				192"	192"
900	77"	153"	230"	306"				220"	220"
1000	75"	149"	224"	299"	373"			267"	267"
1100	89"	179"	268"	358"	447"			319"	319"
1200	88"	176"	264"	352"	440"	528"		375"	375"
1300	94"	188"	282"	376"	470"	564"		404"	404"
1400	93"	186"	279"	371"	464"	557"	650"	464"	464"

**Table 2-1: Slowdown Distances from Terminal Landings**

## 2.7 Directional Limit Switches

The up and down directional limit switches, UN and DN, should be set to open two inches past the terminal floor levels. When the UN limit is open, the controller prevents car movement in the up direction. When the DN limit is open, the controller prevents car movement in the down direction.

## 2.8 Final Limit Switches

The top and bottom final limit switches should be set to open four inches past the terminal floor levels. These limit switches must be mechanical switches.



For the procedure for a running platform during initial start-up, refer to the GALaxy IV Quickstart Guide for M1000 AC Geared Induction or the GALaxy IV Quickstart Guide for M1000 PMAC Gearless, or, see Section 3.2.1 of this manual.

## 2.9 Selector Installation

### 2.9.1 APS (Absolute Position System) Selector Installation

#### 2.9.1.1 Installation of the Encoded Tape



Always handle the encoded tape with care to make sure that the encoded surface of the tape is not damaged. Do not kink the tape or bend the tape in too tight of a radius. When installing the tape, make sure that no grease, dirt, or debris is on the encoded surface of the tape.

The general configuration of the APS (Absolute Position System) Selector is shown in Figure 2-1.

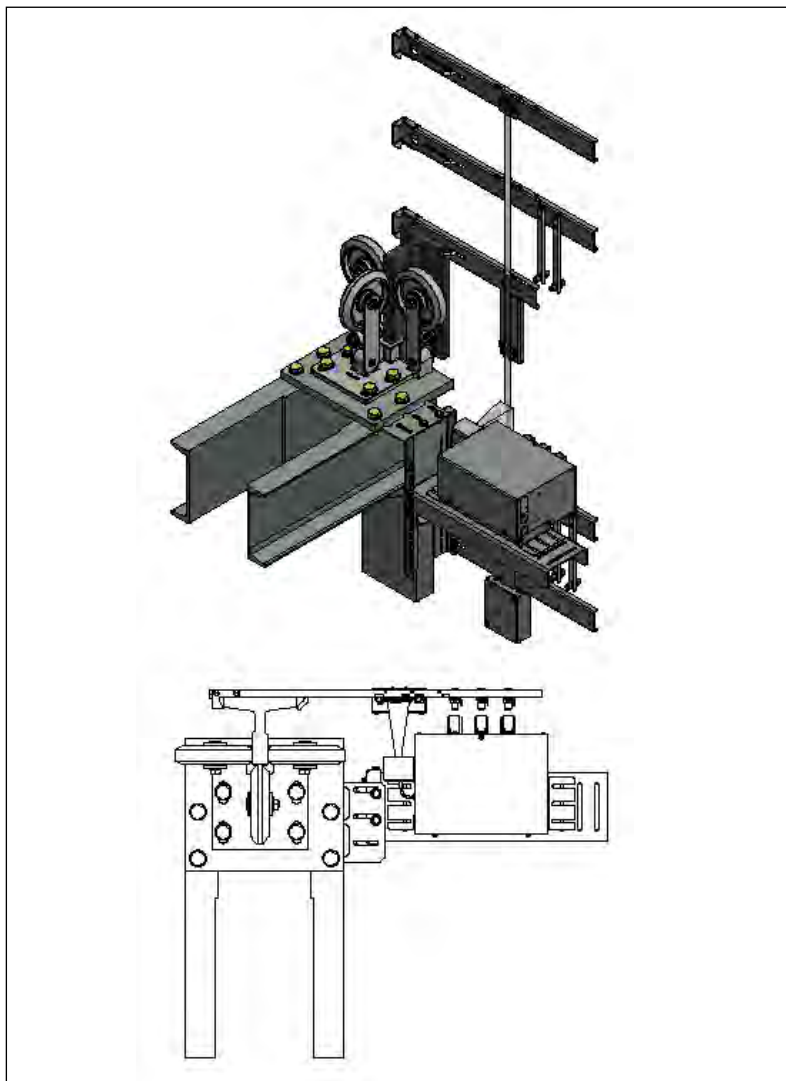

Figure 2-1: General Configuration of the APS Selector

**To install the APS Selector, follow steps 1 through 8 below:**

**Step 1: Install the top selector bracket and attach the encoded tape.**

- Mount the top J-hook selector bracket to the rail.
- Make sure the bracket is high enough that, when counterweight buffer is fully compressed, that the encoded tape is still within the field of view of the APS cameras, and that nothing on the car contacts the bracket.
- Attach the encoded tape to the top bracket keeping the encoded tape as close to the rail as possible. See Figure 2-2.
- Make sure to feed the tape through the front side of the bracket first (the side facing the car), and then bend it around the top of the bracket and lace it back down. Make sure that the encoded side of the tape faces the car and that the "LEFT" markings on the tape are on the left side. See Figures 2-3 and 2-4.
- Fasten the tape with the supplied bracket and screws.



**Figure 2-1: Encoded Tape Mounting – Top Bracket**

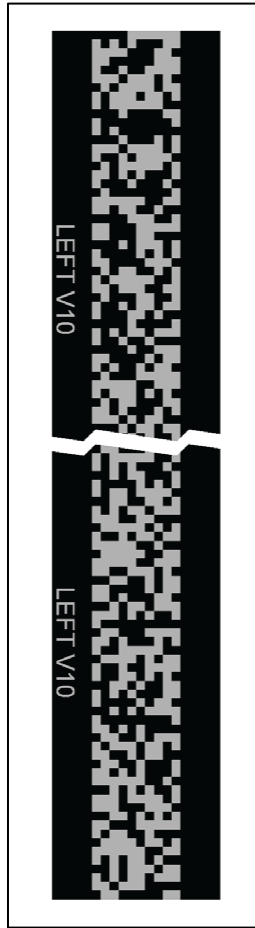

Figure 2-2: Front View of Encoded Tape

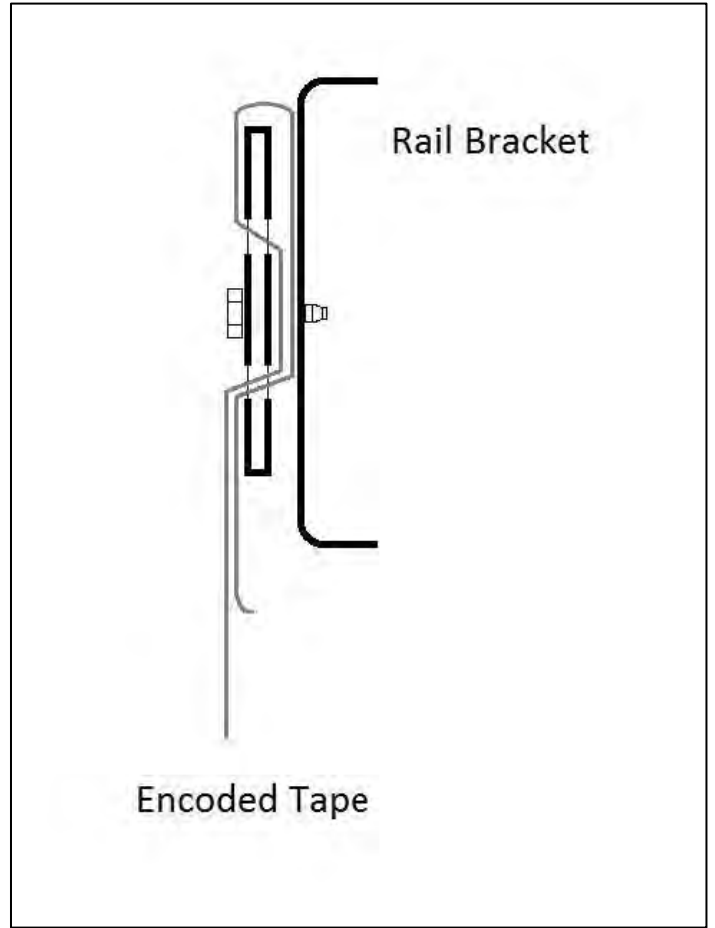

Figure 2-4: Side View of Top Bracket



**Step 2: Run down on inspection while unrolling the encoded tape.**

- Run down on inspection while unrolling the tape. See Figure 2-5.
- Make sure you do not kink the tape or bend it in too tight of a radius. The tape can be damaged, and it should be handled with care.
- Mount a J-hook selector bracket and guide clip with a door zone bridge for each floor. See Figure 2-6.
- When the elevator is at floor level the door zone bridge should be positioned at the midpoint between the two APS cameras. See Figure 2-14. The exact positioning of this bracket and guide clip will be set in section 2.9.2.4.
- Where there are tall floor heights or blind hoistways, mount J-hook selector brackets and guide clips **without** door zone bridges, at locations as needed, that will hold the encoder tape at the proper position with respect to the guide rails and APS camera. See Figure 2-7.
- Make sure your hands are clean and you do not leave any grease or dirt on the front of the tape.



Figure 2-5: Unroll the Encoded Tape



Figure 2-6: Guide Clip with Door Zone Bridge



Figure 2-7: Guide Clip without Door Zone Bridge

**Step 3: Install the bottom selector bracket and attach the encoded tape.**

- Mount the bottom selector bracket onto the car guide rail as shown in 6.
- Make sure the bracket is low enough that, when the car fully compresses car buffer, that the encoded tape is still within the field of view of the APS cameras, and that nothing on the car contacts the bracket. See Figure 2-8.
- Attach the encoded tape to the rail bracket with the slack tape switch.
- Make sure to feed the tape through the front side of the bracket (the side facing the car) first, and then bend it back up toward the back of the tape. See Figure 2-9.
- Push the bracket down until the springs are depressed to the mark in order to properly tension the encoded tape. See Figure 2-10.
- The slack tape switch should be properly installed and wired according to the wiring schematics and connection diagrams.



**Figure 2-8: Encoded Tape Mounting – Bottom Bracket**

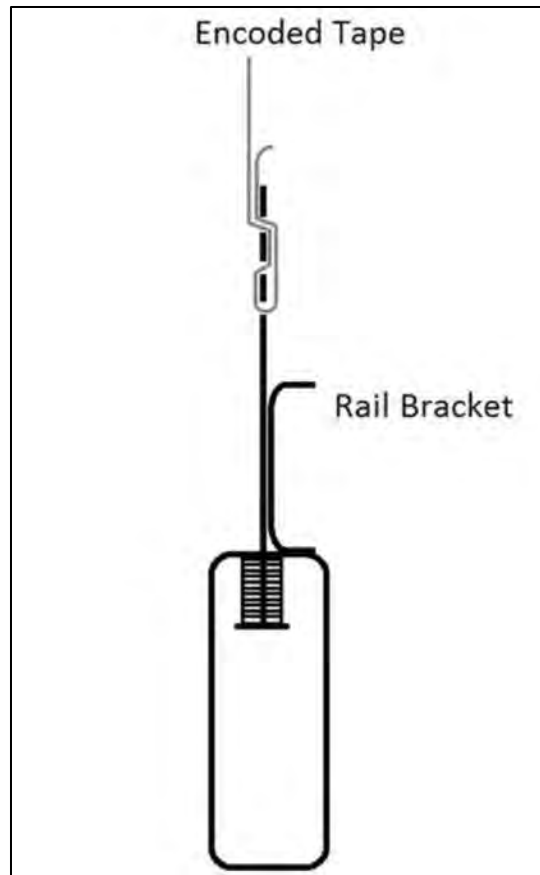

Figure 2-9: Side View of Encoded Tape Attachment to the Bottom Bracket

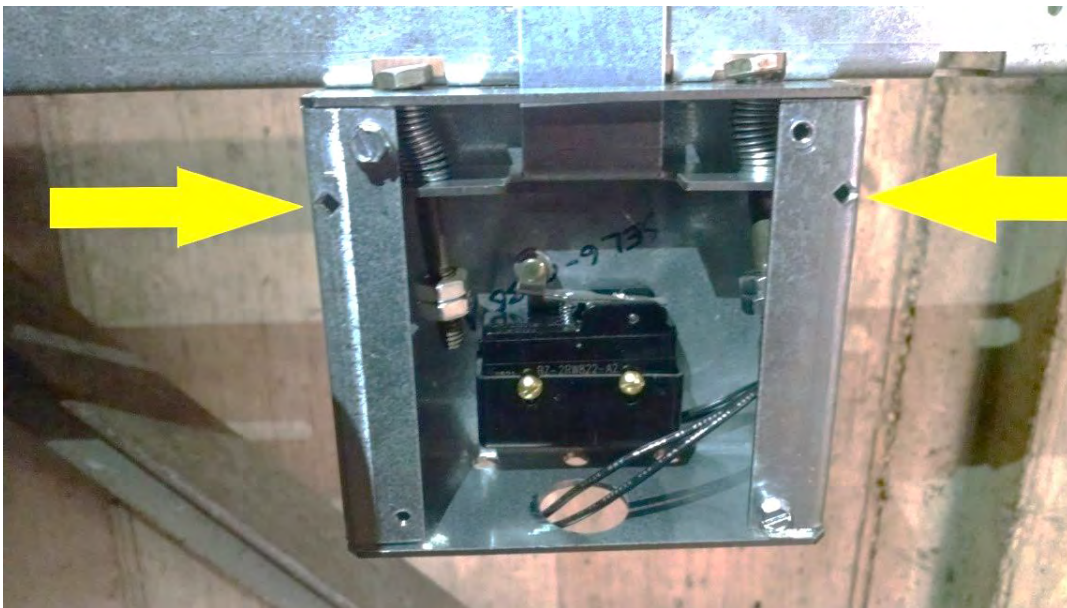
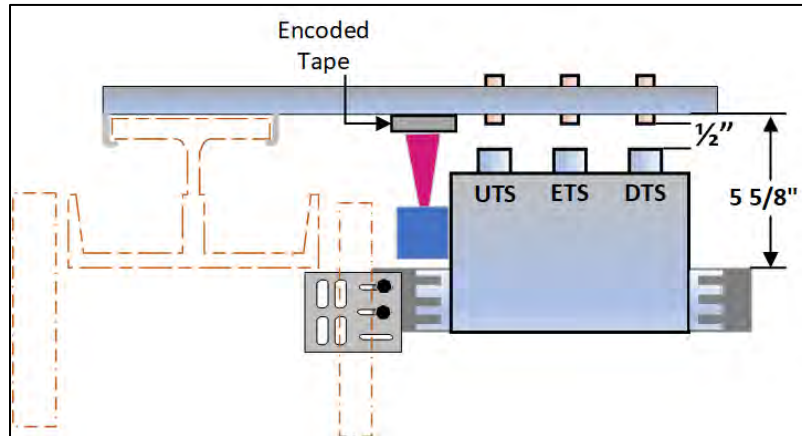

Figure 2-10: Lower Bracket with Springs Properly Compressed to the Marks

**Step 4: Install the selector mounting bracket.**

- Mount the selector mounting bracket to the cross head ensuring that the mounting is plumb and level.
- Use the roller guide base plate bolt to mount the top of the bracket. Use the bracket beam clamp to hold the bottom of the bracket to the flange of the crosshead channel.
- The edge of the bracket closest to the tape should be approximately 5 5/8 inches from the back of the rail. See Figures 2-11 and 2-12.
- The back face of the bracket that is closest to the crosshead should be mounted as close as possible to the crosshead channel.



**Figure 2-11: APS Selector Box and Mounting**

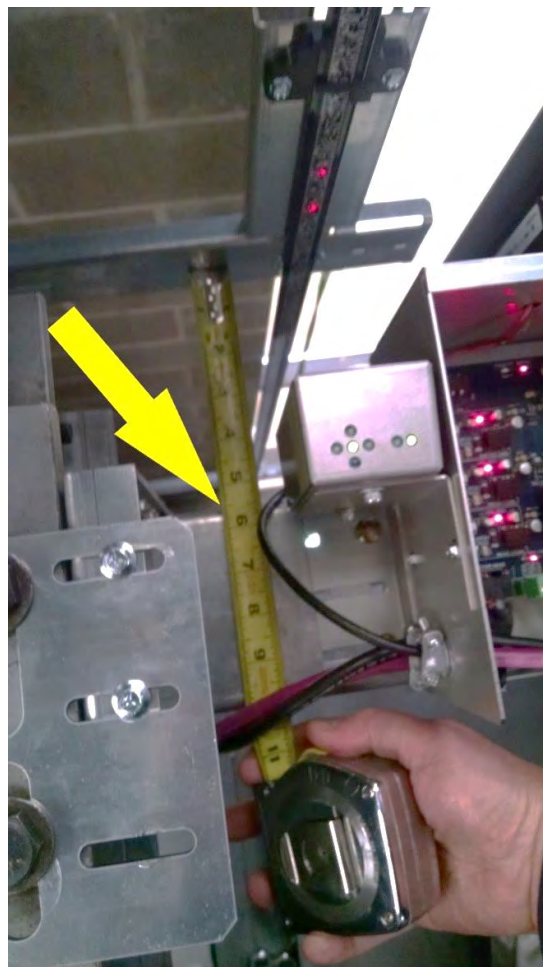

**Figure 2-12: Mounting Bracket 5 5/8" From Back of Rail**

**Step 5: Install the selector box.**

- Mount the selector box on the mounting bracket.
- The APS camera should be centered with the encoded tape.
- The face of the APS camera should be 4 inches from the face encoded tape. See Figure 2-13.

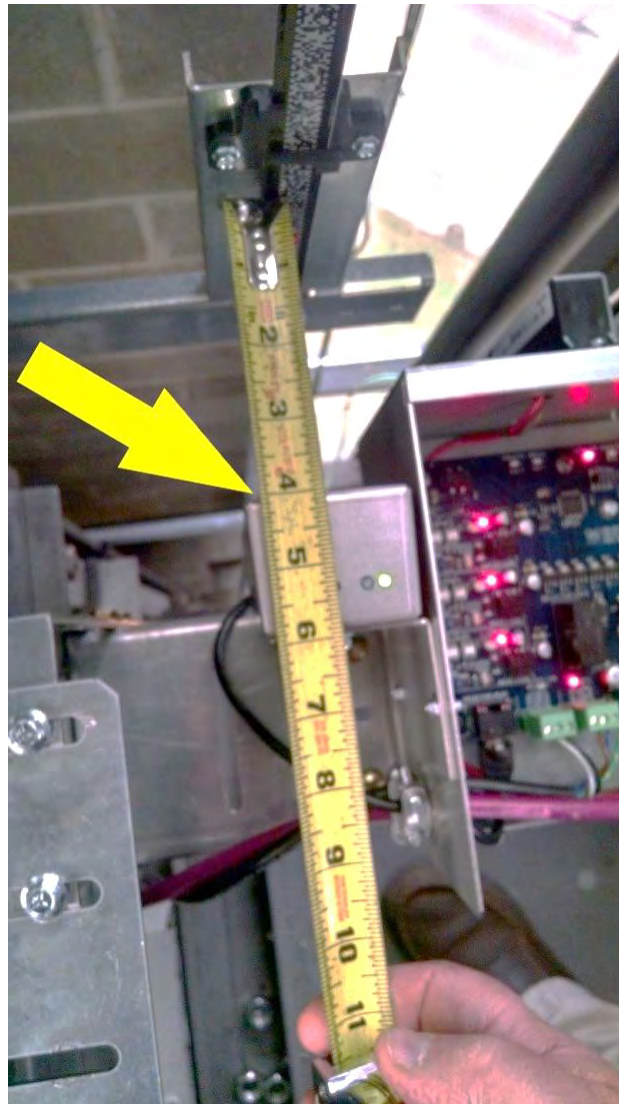

**Figure 2-13: APS Camera 4 Inches from the Encoded Tape**

**Step 6: Install brackets for UTS, DTS, and ETS actuating magnets.**

- Mount a J-hook bracket with a **GREEN** actuating magnet for the UTS magnetic limit switch at the proper distance from the top terminal landing. See Table 2-1 for the proper distance. See Figures 2-11 and 2-14 for the proper position on the J-hook bracket.
- Mount a J-hook bracket with a **RED** actuating magnet for the DTS magnetic limit switch at the proper distance from the bottom terminal landing. See Table 2-1 for the proper distance. See Figures 2-111 and 2-14 for the proper position on the J-hook bracket.
- If the elevator has a reduced stroke buffer, mount J-hook brackets with actuating magnets for the ETS magnetic limit switch at the proper distance from the top and bottom terminal landings using a **GREEN** actuating magnet at the top terminal landing and a **RED** actuating magnet at the bottom terminal landing. See Table 2-1 for the proper distance.
- The actuating magnets should be positioned in the proper lane and adjusted so that the end of the magnet is 1/2 inch from the face of the magnetic switch as the magnetic switch passes the actuating magnet. See Figure 2-11.

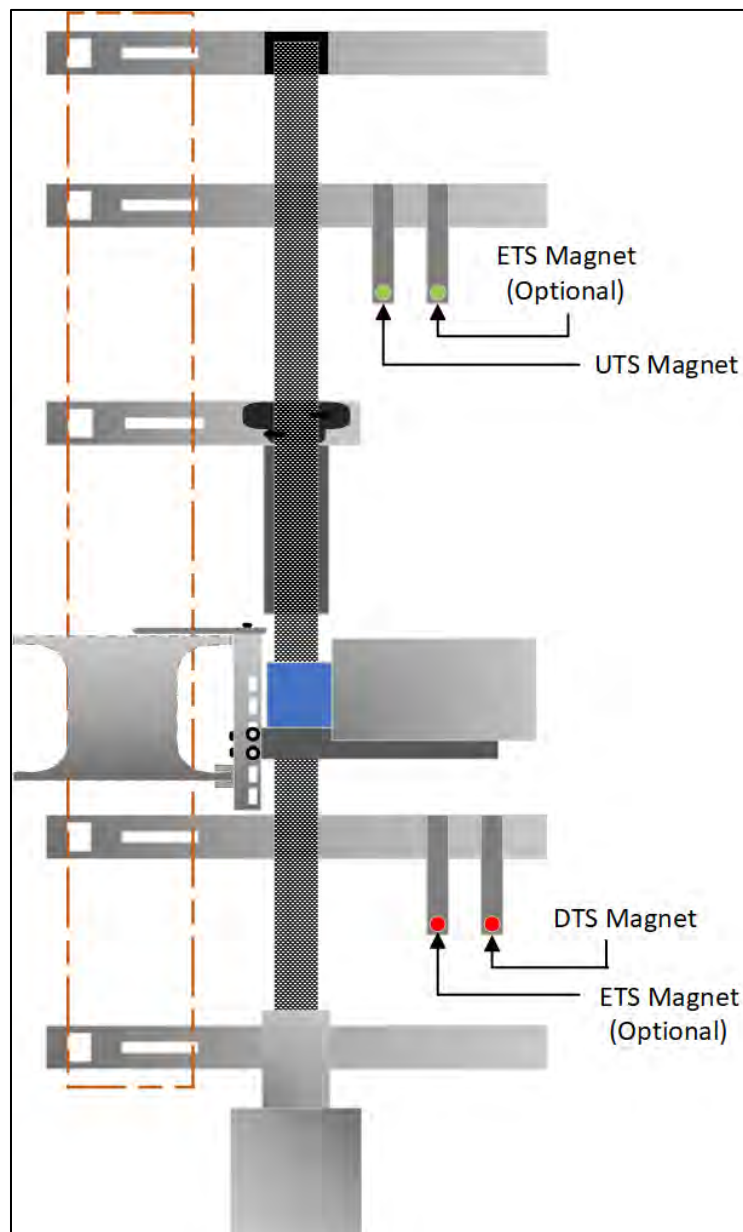
**Figure 2-14: Mounting Brackets for UTS, DTS, and ETS**

**Step 7: Wire the APS selector.**

- Figure 2-15 shows typical wiring connections for the APS selector.
- The APS selector should be wired according to the job specific wiring schematic and connection diagrams.

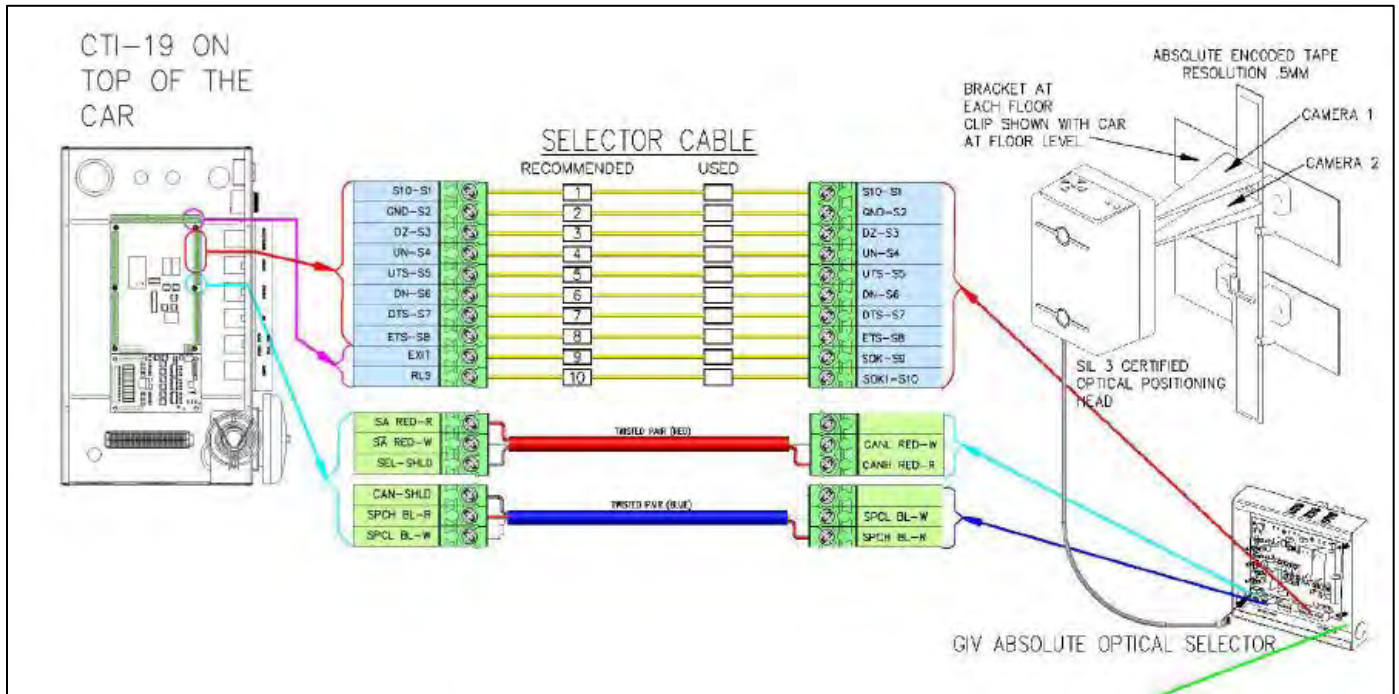

**Figure 2-15: Typical Wiring Connections for the APS Selector**

**i** Prior to performing “Step 8” below, the GALaxy controller must be installed, and the APS selector must be properly wired according to the wiring schematics. See Section 3 of this manual.

**Step 8: Perform a fine adjustment of the APS camera.**

- Make the fine adjustment of the camera using the LED array on the top of the APS camera. See Figure 2-16.
- Adjust the camera so only the green LED in the middle of the 4 red arrows is on. See Figure 2-18.
- Temporarily obstruct the field of view of the APS camera for 5 seconds, and then remove the obstruction. Two red alignment spotlights should appear on the encoded tape. These spotlights represent the center of the field of view of each APS camera. Adjust the camera so the spotlights are in the center of the encoded tape. See Figure 2-17.
- Level the APS camera with a leveling device. The APS camera must be parallel and square to the encoded tape.
- The PWR and STAT LED’s indicate the status of the APS. See Table 2-2.



Figure 2-16: LED Array on APS Camera

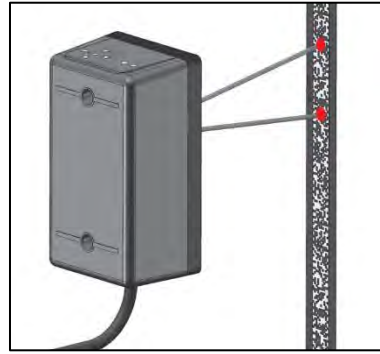

Figure 2-17: APS Camera Alignment Spotlights

LED	Color	Function	OFF	ON	Slow Blinking (1 Hz)	Fast Blinking (5 Hz)
PWR	Green	Supply voltage	No power	Power OK	--	--
STAT	Red	Status signal	No errors	Reading error	APS internal fault	Communication error

Table 2-2: APS Camera, PWR and STAT LED's

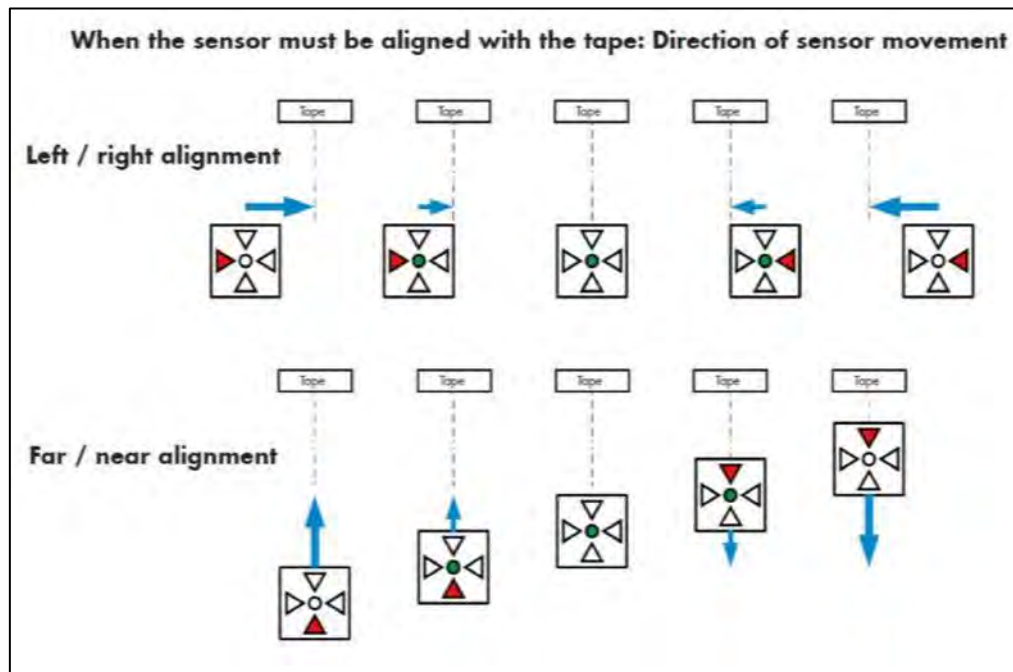

Figure 2-18: Fine Adjustment of the Camera Sensor



### 2.9.1.2 APS Selector Floor Position Setup (Hoistway Learn)

---

The hoistway learn procedure requires that the selector interface board communicates properly with the main CPU through the Safety CAN bus. The hoistway learn procedure also requires that the APS camera module communicates properly with both CPUs on the selector interface board and with the main CPU in the controller.



Proceed to Section 3 of this manual, and, once the “Prepare the Car for Hoistway Learn” section is reached in section 3.3.7, return to section 2.9.1.3.

### 2.9.1.3 Verify that the APS Selector is Installed Correctly and Communicating

---

From the Diagnostic menu on the LCD Interface, select the APS Selector Can Status. Verify that the APS Sel to Main CPU RxCnt is counting, and that the On-line status equals 1. APSM, on the display, refers to the communications to the main CPU, whereas, APS2 refers to the communications to Processor 2 on the selector interface board. Continue through the menu items to verify that the CntA value for APSM is not zero, that there are no Errors or Warnings, that the alignment is centered, and that the contrast shows OK. Also verify that the APS2 status shows that the RxCnt is counting and that the On-line status equals 1. Continue to verify that the CntB value for APS2 is not zero, that there are no Errors or Warnings, that the alignment is centered, and that contrast shows OK. Note that the RxCnt for the APS2 device will increment much slower than for the Main CPU.

### 2.9.1.4 Setting the APS Adjustable Variables

---

Set the following parameters in the “APS Selector Adjustable Variables” sub-menu prior to recording the floor positions.

- Set “Top Speed” to the contract speed of the job.
- Set “Number Valid Floors” to the number of floors with openings on this elevator.
- Set “Number of Limits” to the number of slow down limits required per terminal landing for the specific job speed. Refer to Table 2-1, “Slowdown Distances From Terminal Landings”. Example: 350fpm job would be set to 2 limits.
- Set UT/DT Dist. If set to zero, the distance is set automatically from the slowdown table in the manual. If this parameter is changed, it will not take effect until a learn operation is completed at the top and bottom floor. It is recommended to set this parameter to zero unless the slowdown distances need to be adjusted.
- Set UT1/DT1... UT3/DT3 if required. If set to zero, the distance is set automatically from the slowdown table in the manual. If this parameter is changed, it will not take effect until a learn operation is completed at the top and bottom floor. It is recommended to set these parameters to zero unless the slowdown distances need to be adjusted.
- Set Can Baud Rate to 0. 0 is 115.2K Baud. This parameter should not need to be changed.

### 2.9.1.5 Zero the Hoistway

---

After the APS selector parameters are setup, continue the following steps to zero the hoistway table. From the Elevator Setup menu, select Learn Hoistway and follow the flowchart shown in Figure 2-19. Notice that the number of valid floors, number of limits, and top speed will be verified. Be sure to select YES for First Time Setup and press enter. When the message, “Setup Active. Press Up or Dn to Scroll through” is displayed, press Mode to escape to the main menu. Proceed to section 2.9.1.6, “Setting Hoistway Floor Levels with APS Selector”, in the adjustment manual.

**LCD Interface  
Learn Hoistway Submenu**

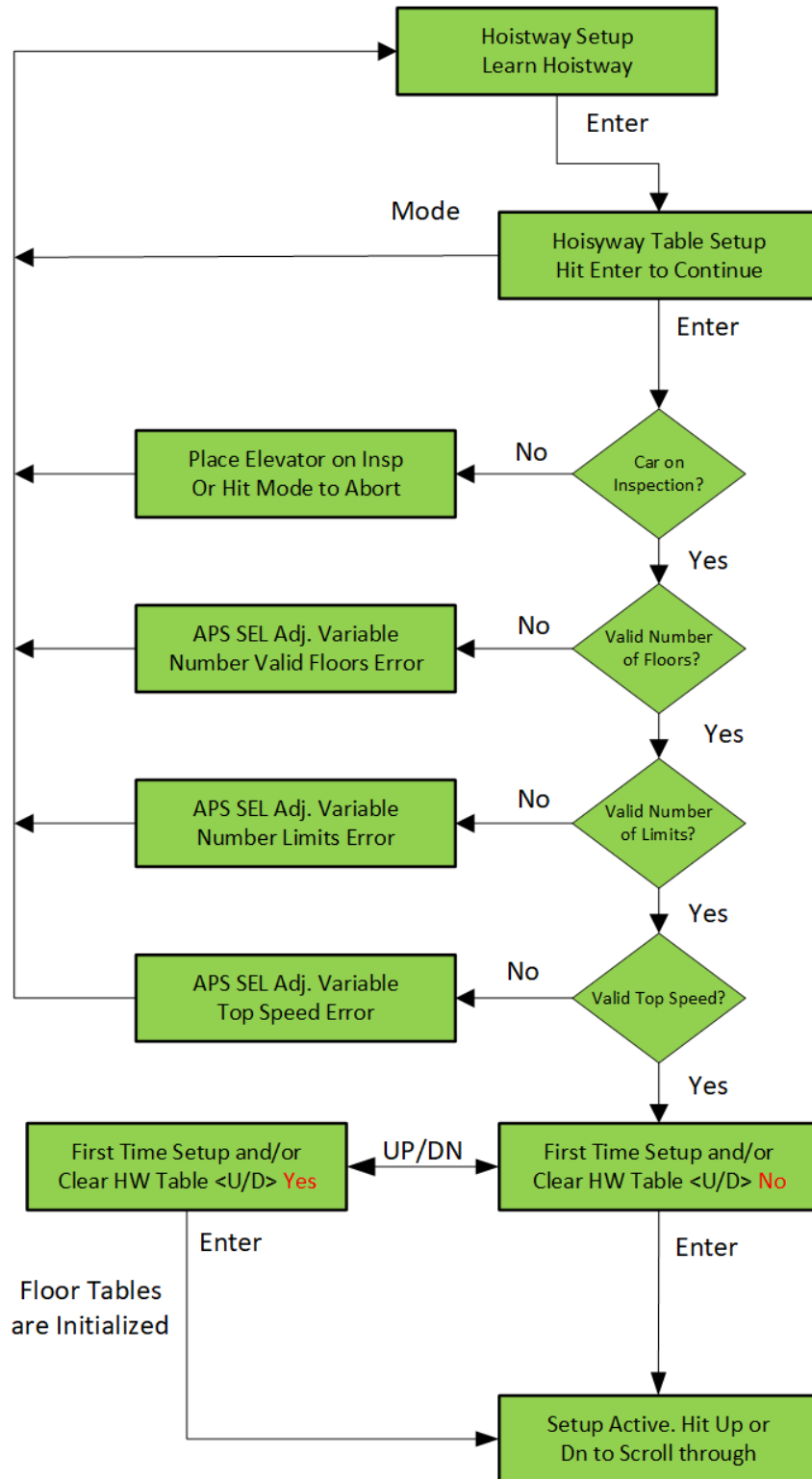

Figure 2-19: Flowchart for Learn Hoistway Submenu

### 2.9.1.6 Setting Hoistway Floor Levels with APS Selector

- Put the elevator on car top inspection.



Temporarily set the car door bypass switch to the BYPASS position. Setting the car door bypass switch to the BYPASS position will allow the car to be moved on car top inspection with the car door open. All safety precautions must be followed to ensure the safety of elevator personnel and the general public when moving the car on car top inspection with the car door bypass switch in the BYPASS position.

- Move the jumper on the GALX-1133AN selector board to the SETUP position. See Figure 2-20.

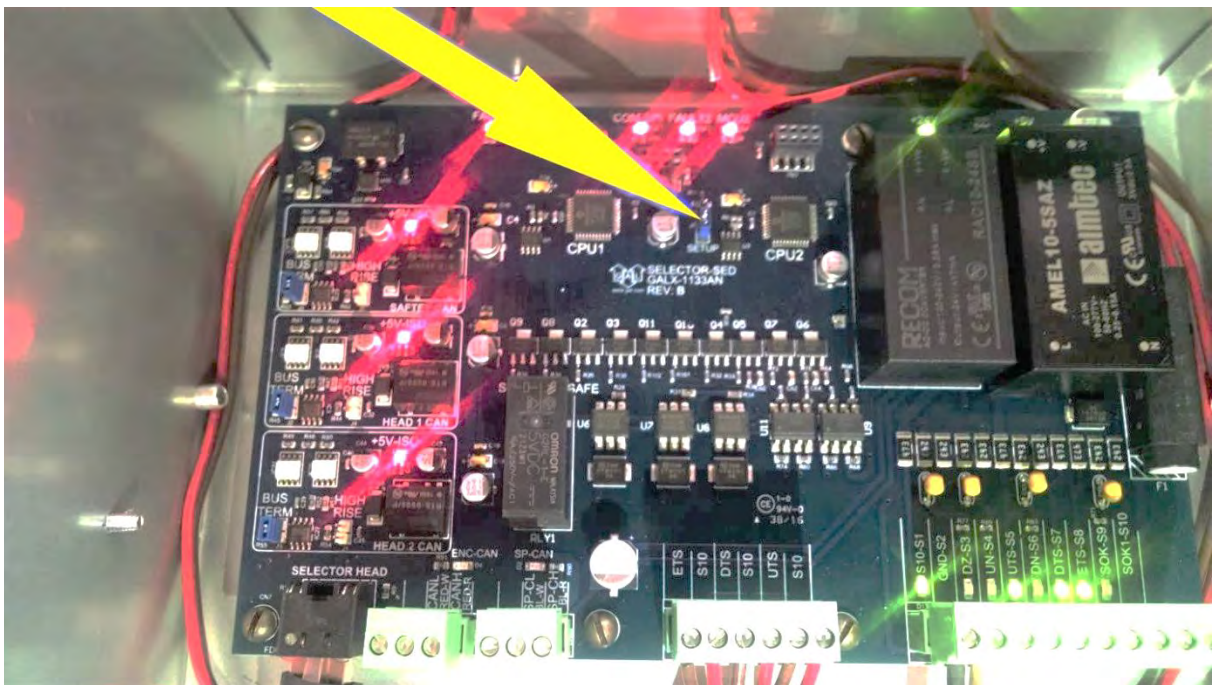

Figure 2-20: APS Selector Board Setup Jumper

- Move the car on inspection so that it is exactly level with a floor.



Pressing the door open button, while moving the car on inspection, will change the inspection speed to 3 fpm during the inspection run. This allows the car to be positioned at exactly floor level. The inspection speed will return to the value set for “Inspect Speed” in the “Car Motion” Sub Menu when the door open button is not pressed.

- Adjust the J-hook bracket and guide clip so the door zone bridge is positioned at the midpoint between the two APS cameras. If the alignment spotlights are not visible, temporarily obstruct the field of view of the APS camera for 5 seconds, and then remove the obstruction. Two red alignment spotlights should appear on the encoded tape. See Figures 2-17 and 2-21.



**Figure 2-21: APS Selector Alignment Spotlights**

- To record the floor position, press the buttons on the car operating panel in the following sequence.
  - Press the 2<sup>nd</sup> floor car call button
  - Press the 1<sup>st</sup> floor car call button
  - Press the 2<sup>nd</sup> floor car call button
  - Press the 1<sup>st</sup> floor car call button
  - Press the Door close button

The car call light for floors 1 and 2 will illuminate momentarily and then turn off. After the two car call lights turn off, press the following button on the car operating panel.

- Press the car call button for the floor where the car is currently located.

This car call light will flash on and off for approximately 5 seconds and then remain off. This indicates that the floor position was recorded successfully. If the car call light does not flash, but remains illuminated, the floor was not recorded successfully. If the floor position was not recorded successfully, verify that the APS SEL adjustable variables are set properly.



The 1<sup>st</sup> floor car call is the car call for the bottom terminal landing. The 2<sup>nd</sup> floor car call is the car call for the landing that is one floor above bottom terminal landing. The actual floor markings for these floors may not be “1” and “2”.

- Repeat this process until all valid floors have been recorded.
- Move the jumper on the GALX-1133AN board to the RUN position and exit the car.



Set the car door bypass switch to the OFF position.

- The hoistway learn is now complete.
- Position the car near a floor.
- Put the car in automatic operation with the AUTO DOOR switch set to the OFF position.
- The car should level into the floor. Proceed to section 3.7, “Final Adjustment”.

## 2.9.2 Tapeless Selector Installation

### 2.9.2.1 Tapeless Selector 7

The “Tapeless Selector 7” utilizes a governor mounted CAN Open encoder and encoder cable. The CAN Open encoder must be properly installed on a governor that has a rotating center shaft, and the encoder cable must be connected to the controller as shown in the wiring schematics and connection diagrams. The “Tapeless Selector 7” includes a leveling sensor box and a limit switch box that are to be mounted on top of the car.

The general configuration of the “Tapeless Selector 7” is shown in Figure 2-22.

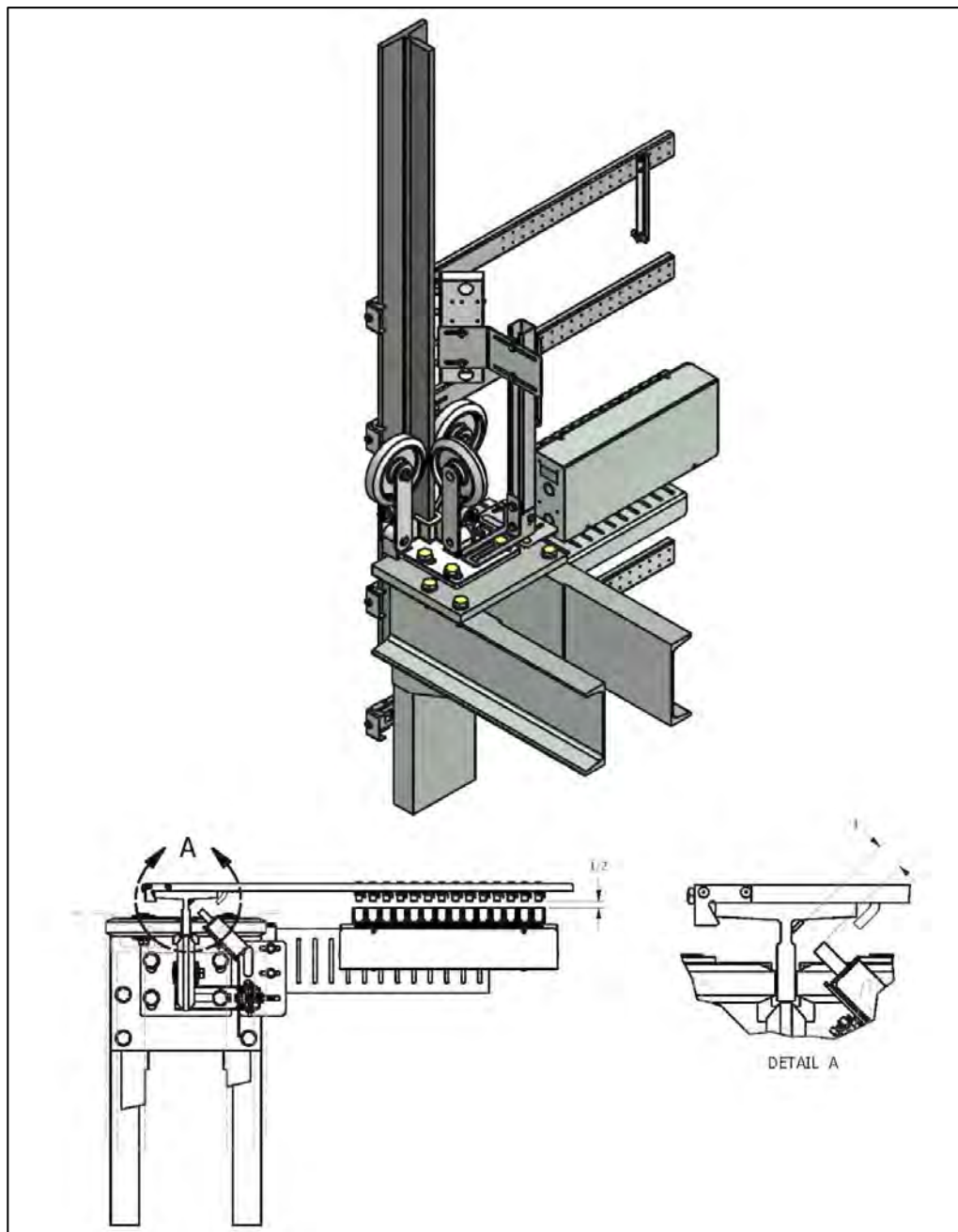
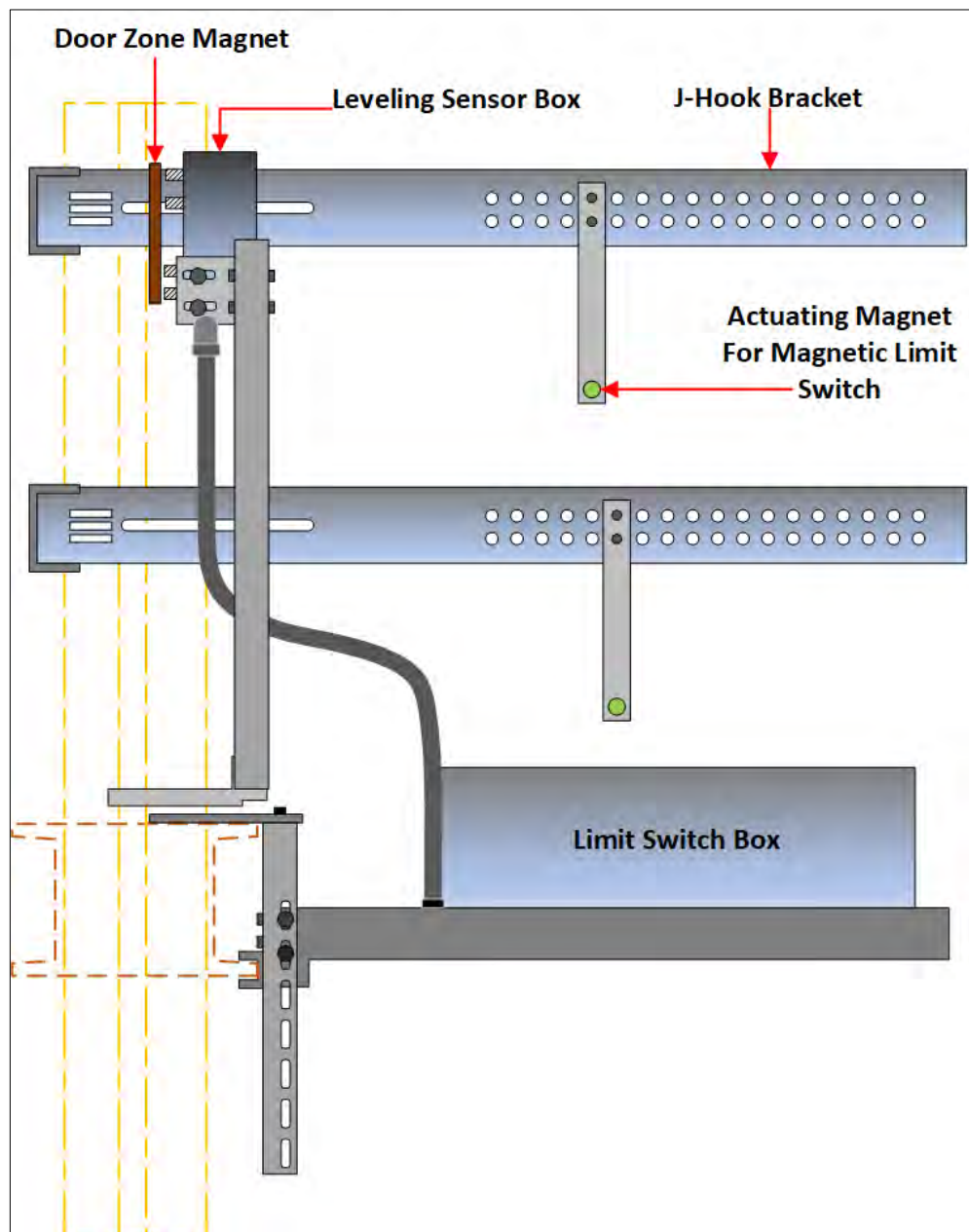

**Figure 2-22: General Configuration of the Tapeless Selector 7  
(Dimensions are in inches)**

**To install the Tapeless Selector 7, follow steps 1 through 4 below:**

**Step 1: Install the limit switch box.**

- Mount the limit switch box mounting bracket to the cross head ensuring that the mounting is plumb and level. See Figure 2-23.
- Use the roller guide base plate bolt to mount the top of the bracket. Use the bracket beam clamp to hold the bottom of the bracket to the flange of the crosshead channel.
- The edge of the bracket closest to the J-hook brackets should be approximately 3 inches from the back of the rail. See Figures 2-24.
- The back face of the bracket that is closest to the crosshead should be mounted as close as possible to the crosshead channel.
- Mount the limit switch box to the mounting bracket. The selector box should be positioned to allow for a distance of 1/2 inch from the face of the magnetic switch to the end of the actuating magnets that will be installed in step 3. See Figures 2-23 and 2-24.



**Figure 2-23: Tapeless Selector 7 Mounting Bracket Side View**

- The limit switch box includes magnetic switches for the following input signals.
  - UT, DT
  - UT1, UT2, UT3 (UT4, UT5, UT6 if required)
  - DT1, DT2, DT3 (DT4, DT5, DT6 if required)
  - UTS, DTS
  - UN, DN
  - ETS (if required)

These magnetic switches are actuated by magnets as the car approaches the terminal landings. These magnets are cylindrical in shape and are mounted to brackets that are positioned at the proper distance from the terminal landings. See Step 3.

The following items may vary depending on the speed of the elevator.

- The number of magnetic switches in the limit switch box
- The location of the magnetic switches in the limit switch box
- The size of the limit switch box

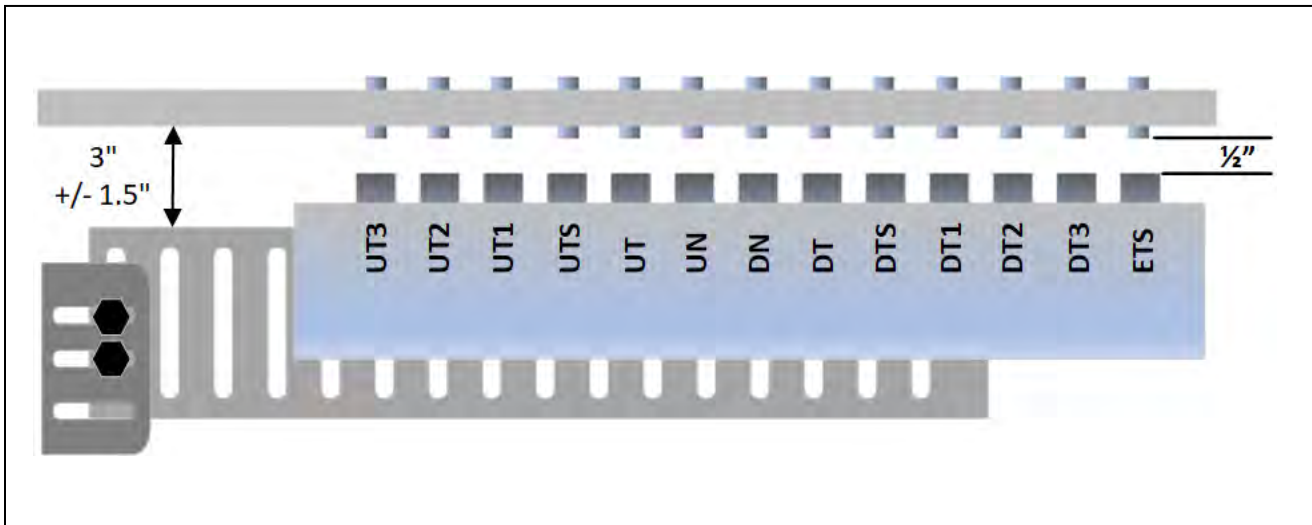

**Figure 2-24: Tapeless Selector 7 Limit Switch Box Top View**  
(Dimensions are in inches)

**Step 2: Install the leveling sensor box.**

- Mount the leveling sensor box using the Unistrut bracket and roller guide mounting bolts.
- The leveling sensor box includes sensors for inputs signals UL, DZU, DZD, and DL. See Figure 2-25.
- The leveling sensor box should be mounted such that the sensors are positioned at a 45-degree angle with respect to the face of the rail.
- Install the 8-inch floor magnets on the rail at every floor. The 8-inch floor magnet should be placed in the corner of the rail as shown in "Detail A" in Figure 2-26. When the car is at floor level, the centerline of the 8-inch floor magnet should be at the same height as the centerline of the UL and DL sensors.



It is important to limit the side-to-side movement of the car to 1/4" between the rails to maintain consistent floor levels and to prevent nuisance faults. After final adjustment, the 8-inch floor level magnets should be secured with an adequate amount of adhesive caulk in order to prevent movement.

- Adjust the leveling sensor box and the leveling sensors so that the ends of the sensors are 1-inch from the face of the magnet. See Figure 2-26. The UL and DL sensors are mounted in slotted holes to allow fine adjustment of the "floor level zone" in section 3.7.3. However, these sensors should be set in the middle of the adjustment slot as a starting point prior to final adjustment.

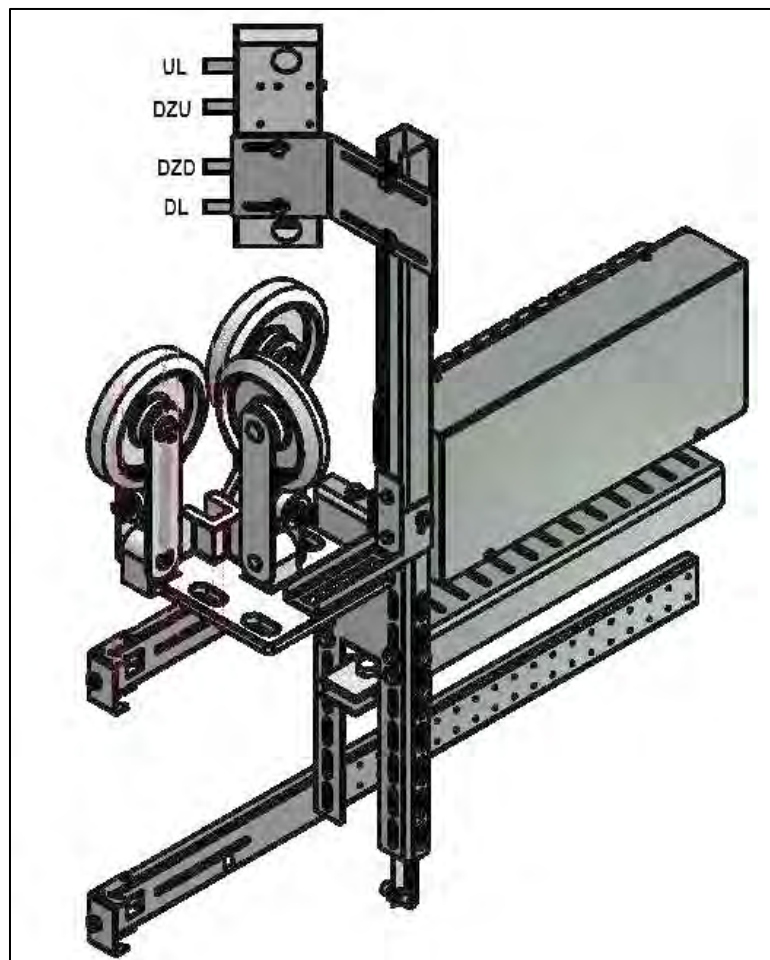

**Figure 2-25: Tapeless Selector 7 Leveling Sensor Box**



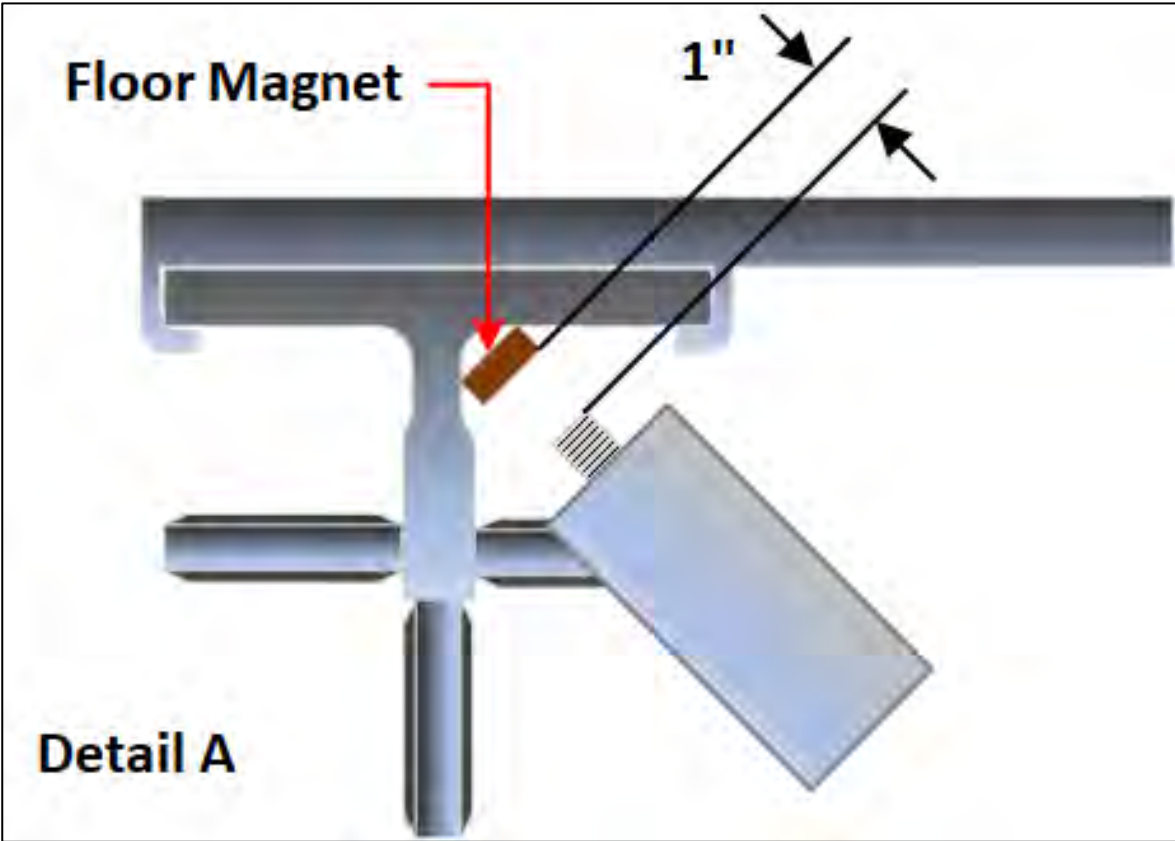

Figure 2-26: Tapeless Selector 7 Leveling Floor Magnet Placement  
(Dimensions are in inches)

**Step 3: Install brackets for the limit actuating magnets.**

- Mount a J-hook bracket with a **GREEN** actuating magnet for each magnetic limit switch at the proper distance from the top terminal landing. See Table 2-1 for the proper distance. See Figures 2-23 and 2-24 for the proper position of the actuating magnet on the J-hook bracket.
- Mount a J-hook bracket with a **RED** actuating magnet for each magnetic limit switch at the proper distance from the bottom terminal landing. See Table 2-1 for the proper distance. See Figures 2-23 and 2-24 for the proper position of the actuating magnet on the J-hook bracket.
- If the elevator has a reduced stroke buffer, mount J-hook brackets with actuating magnets for the ETS magnetic limit switch at the proper distance from the top and bottom terminal landings using a **GREEN** actuating magnet at the top terminal landing and a **RED** actuating magnet at the bottom terminal landing. See Table 2-1 for the proper distance.
- A J-hook bracket and **GREEN** actuating magnet, for the UN magnetic switch, should be positioned to activate the switch when the car is 2 inches above the top terminal floor level.
- A J-hook bracket and **RED** actuating magnet, for the DN magnetic switch, should be positioned to activate the switch when the car is 2 inches below the bottom terminal landing.
- The actuating magnets should be adjusted so that the end of the magnet is 1/2 inch from the face of the magnetic switch as the magnetic switch passes the actuating magnet. See Figure 2-24.

**Step 4: Wire the Tapeless Selector 7.**

- Figure 2-27 shows typical wiring connections for the Tapeless Selector 7.
- The Tapeless Selector 7 should be wired according to the job specific wiring schematic and connection diagrams.
- Proceed to section 3, "GALaxy IV Adjustment – Combivert F5 AC Drive".

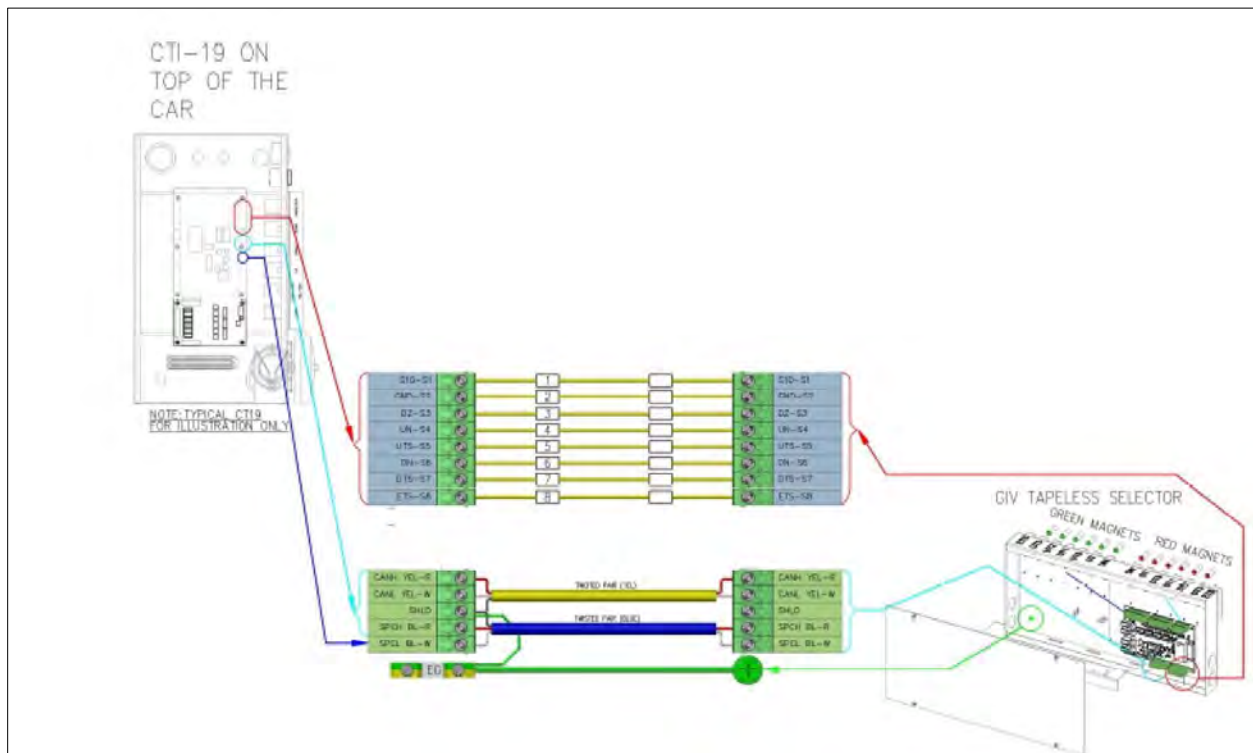

**Figure 2-27: Tapeless Selector 7 Wiring**

2.9.2.2 Tapeless Selector 5

The “Tapeless Selector 5” utilizes a governor mounted CAN Open encoder and encoder cable. The CAN Open encoder must be properly installed on a governor that has a rotating center shaft, and the encoder cable must be connected to the controller as shown in the wiring schematics and connection diagrams.

The “Tapeless Selector 5” is similar to the “Tapeless Selector 7”. However, the “Tapeless Selector 5” includes the leveling sensors within the limit switch box and requires a J-hook bracket at each floor for mounting the floor magnet. See Figures 2-28, 2-29, and 2-30.

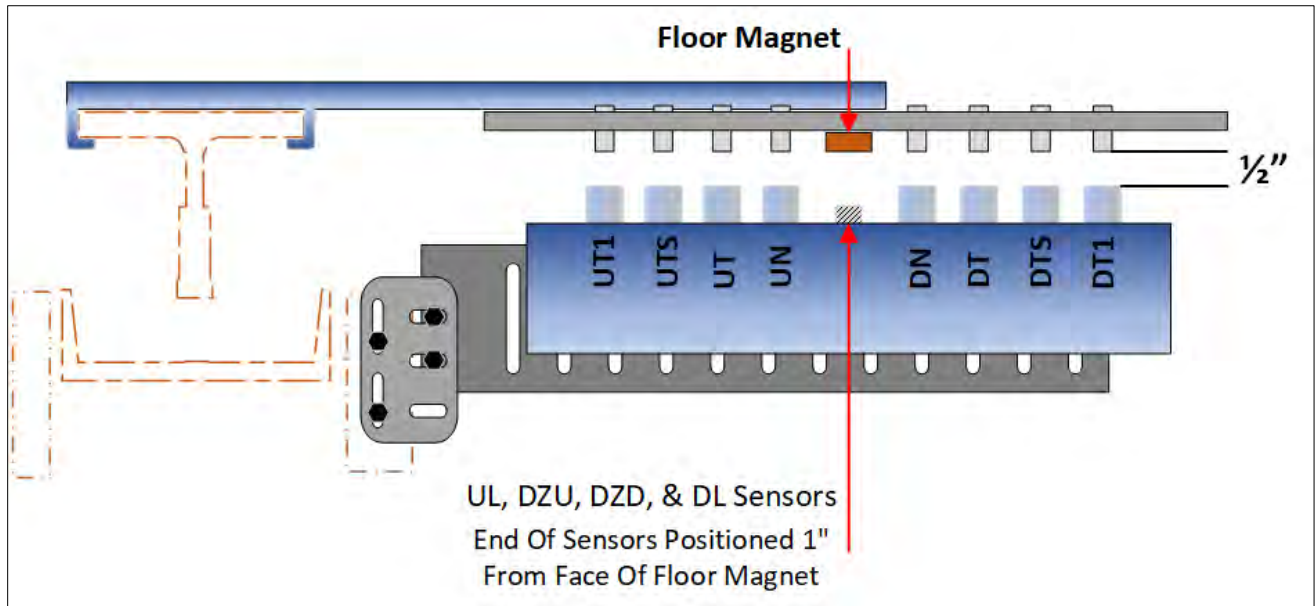

Figure 2-28: Tapeless Selector 5 Top View.  
(Dimensions are in inches)

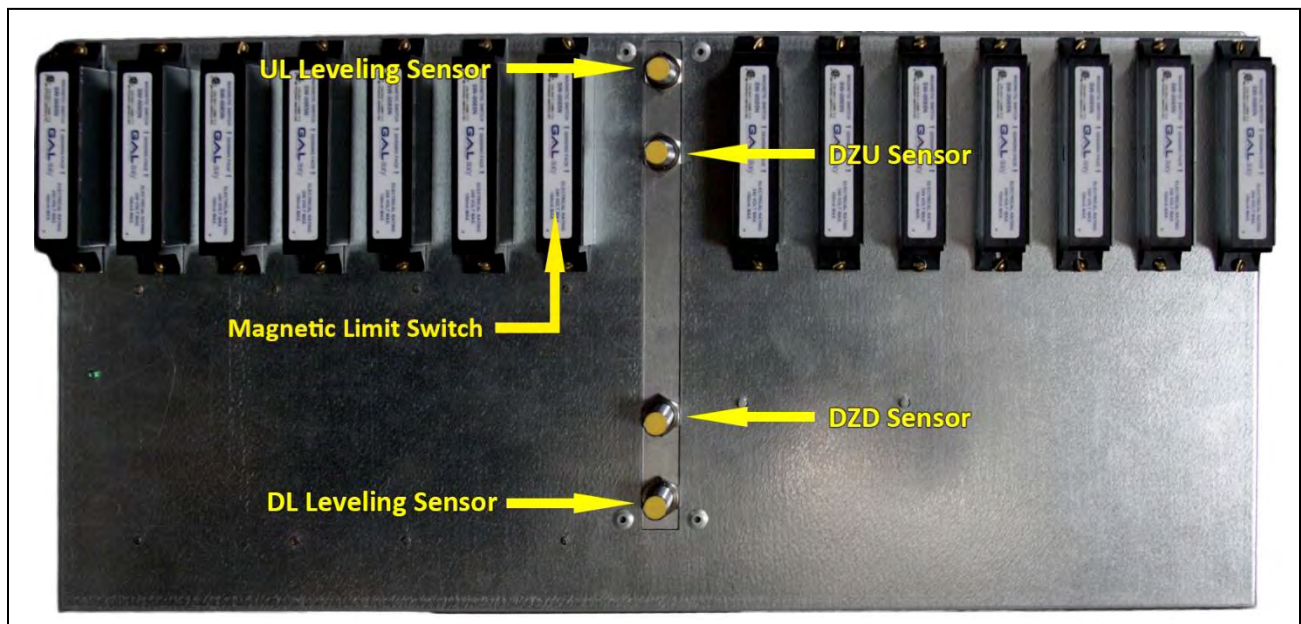

Figure 2-29: Tapeless Selector 5 Limit Switch Box With Leveling Sensors

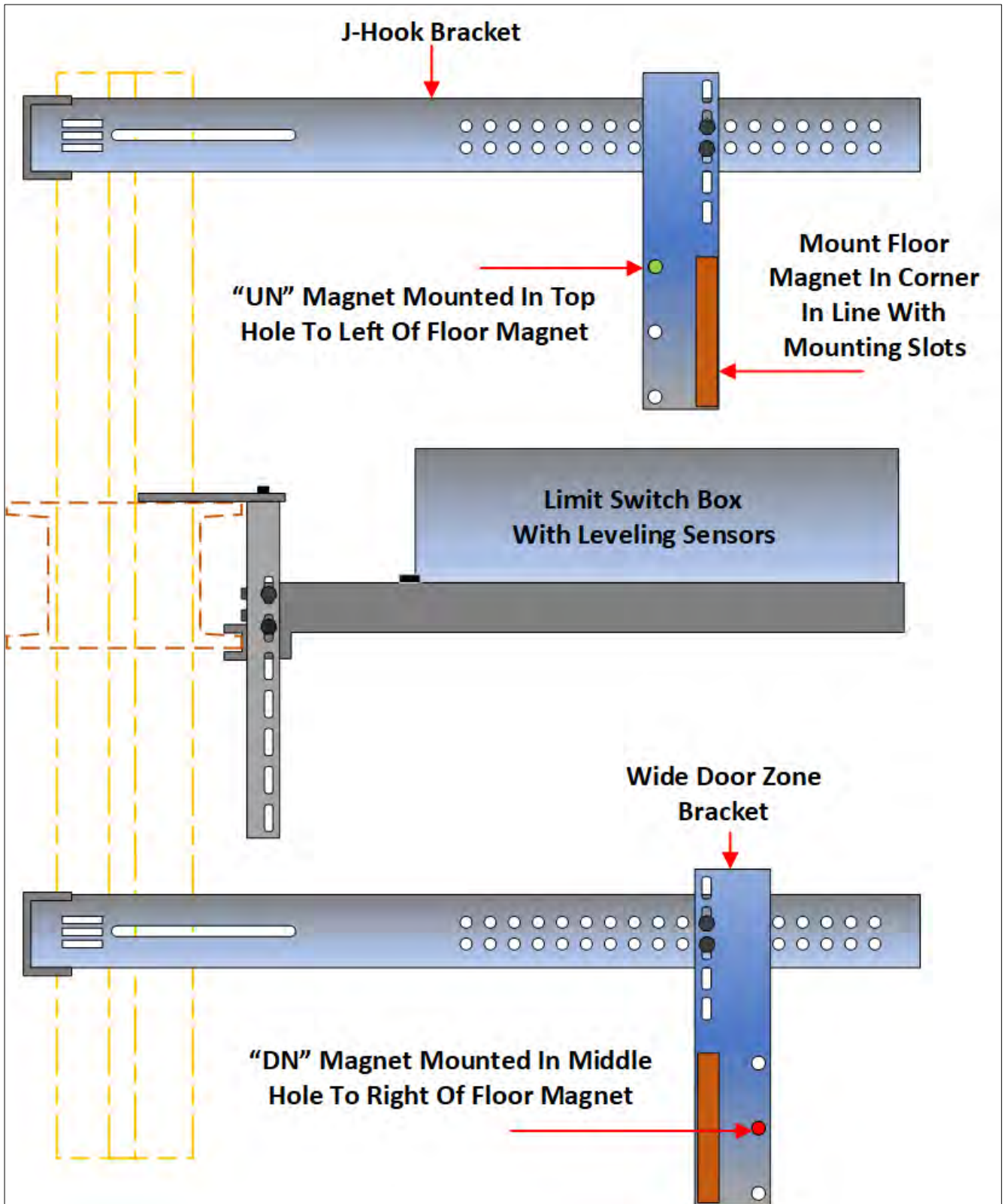

Figure 2-30: Tapeless Selector 5 Side View.  
Dimensions are in inches.

**To install the Tapeless Selector 5, follow steps 1 through 3 below:**

**Step 1: Install the limit switch box with leveling sensors.**

- Mount the limit switch box mounting bracket to the cross head ensuring that the mounting is plumb and level. See Figures 2-28 and 2-30.
- Use the roller guide base plate bolt to mount the top of the bracket. Use the bracket beam clamp to hold the bottom of the bracket to the flange of the crosshead channel.
- The back face of the bracket that is closest to the crosshead should be mounted as close as possible to the crosshead channel.
- Mount the limit switch box to the mounting brackets. The selector box should be positioned to allow for a distance of 1/2 inch from the face of the magnetic switch to the end of the actuating magnets that will be installed in step 3. See Figures 2-28 and 2-30.
- The limit switch box includes magnetic switches for the following input signals.
  - UT, DT
  - UT1 (UT2, UT3, UT4, UT5, UT6 if required)
  - DT1 (DT2, DT3, DT4, DT5, DT6 if required)
  - UTS, DTS
  - UN, DN
  - ETS (if required)

These magnetic switches are actuated by magnets as the car approaches the terminal landings. These magnets are cylindrical in shape and are mounted to brackets that are positioned at the proper distance from the terminal landings. See Step 3.

The following items may vary depending on the speed of the elevator.

- The number of magnetic switches in the limit switch box
- The location of the magnetic switches in the limit switch box
- The size of the limit switch box

See Figures 2-28, 2-29, and 2-30.

**Step 2: Install brackets for floor level magnets.**

- Mount a J-hook bracket at each floor for the floor level magnet. See Figures 2-28 and 2-30.
- Mount the narrow metal door zone brackets to each J-hook bracket for the intermediate floors.
- Mount the wide metal door zone brackets to the J-hook brackets for the top and bottom terminal floors. See Figure 2-30.
- Install an 8-inch floor level magnet on each door zone bracket.
- Adjust the leveling sensors so that the end of the sensors are 1 inch from the face of the floor magnet. See Figure 2-28. This distance may be adjusted in section 3.3.8.3 to provide the correct “floor level zone”.
- When the car is at floor level, the centerline of the 8-inch floor magnet should be at the same height as the centerline of the UL and DL sensors.

**Step 3: Install brackets for the limit actuating magnets.**

- Mount a J-hook bracket with a **GREEN** actuating magnet for each magnetic limit switch at the proper distance from the top terminal landing. See Table 2-1 for the proper distance. See Figures 2-28 and 2-30. for the proper position of the actuating magnet on the J-hook bracket.
- Mount a J-hook bracket with a **RED** actuating magnet for each magnetic limit switch at the proper distance from the bottom terminal landing. See Table 2-1 for the proper distance. See Figures 2-28 and 2-30 for the proper position of the actuating magnet on the J-hook bracket.
- If the elevator has a reduced stroke buffer, mount J-hook brackets with actuating magnets for the ETS magnetic limit switch at the proper distance from the top and bottom terminal landings using a **GREEN** actuating magnet at the top terminal landing and a **RED** actuating magnet at the bottom terminal landing. See Table 2-1 for the proper distance.
- A J-hook bracket and **GREEN** actuating magnet, for the UN magnetic switch, should be positioned to activate the switch when the car is 2 inches above the top terminal floor level. The UN actuating magnet should be mounted in the top hole of the wide door zone bracket at the top terminal landing. See Figure 2-30.
- A J-hook bracket and **RED** actuating magnet, for the DN magnetic switch, should be positioned to activate the switch when the car is 2 inches below the bottom terminal landing. The DN actuating magnet should be mounted in the middle hole of the wide door zone bracket at the bottom terminal landing. See Figure 2-30.
- The actuating magnets should be adjusted so that the end of the magnet is 1/2 inch from the face of the magnetic switch as the magnetic switch passes the actuating magnet. See Figure 2-28.

## Section 3 - GALaxy Adjustment

---

### 3.1 Procedure for Initial Power-up of Controller

---

#### 3.1.1 Checking Main Line Voltage

---

Prior to powering up the controller, making drive adjustments, or attempting to run the hoist motor, the following steps should be completed:

- Familiarize yourself with the wiring schematics.
- Familiarize yourself with the Magnetek M1000 AC Elevator Drive Technical Manual.



All safety precautions, including precautions related to electrical safety, must be followed to ensure the safety of elevator personnel and the general public.

- Before applying power to the controller, the following items should be verified by the **proper electrical authority**.
  - Verify that the disconnecting means is properly sized and is lockable.
  - Verify that the voltage supplying the elevator controller is correct as indicated on the “Controller Input” of the controller data tag.
  - Verify that the conductors supplying the disconnecting means are properly sized.
  - Verify that the conductors from the disconnecting means to the controller are properly sized.
  - Verify that power supply feeding the controller has the proper fuse protection or circuit breaker protection.
  - Verify that the power supply feeding the controller is properly grounded and that the grounding conductor is properly sized.

#### 3.1.2 Checking Controller Voltages

---

Turn the main line disconnect to the ON position. Check the voltage at points **L1**, **L2**, and **L3** on the DC drive. Verify that all three phases are present.

Check the voltage at fuses **L1** and **L2** on controller. If correct, then check the voltage at terminals **L1N** and **24VI** with respect to ground (**GND**). The voltage readings should be 120VAC for **L1N** and 24VAC for **24VI**. If these are correct, check the voltage at terminals **S10**, **L120**, & **L24** with respect to ground (**GND**). The voltage reading at terminals **S10** and **L120** should read 120VAC, and **L24** should read 24VAC. If any of these voltage readings are not correct, then check wiring diagram to determine the problem before continuing. Verify, from the schematic, the required voltages for **FEP** and **HCP** for this controller. Either supply can be wired for 24VAC or 120VAC. Verify the voltages on the terminals match the voltages on the schematic.

#### 3.1.3 Verifying Operation of the Main CPU

---

Verify that the “axy” of “GALaxy”, displayed on the 1005/1101 LCD Interface, is flashing. If the “axy” is flashing, then proceed to the next step. If the “axy” is not flashing, check voltages at the 5V to 0V terminals on the 1102 Main I/O Board, to ensure 5VDC is present across these terminals. If 5VDC is present and the “axy” on the 1005/1101 LCD Interface is not flashing, then contact factory.

### 3.2 Start-up Procedures

#### 3.2.1 Requirements for a running platform during initial startup

- 1) Wire Motor and Main Line Power as shown in the job connection diagrams.
- 2) Install and wire Governor as shown in the job connection diagrams.
- 3) Wire the motor encoder cable as shown in the job connection diagrams.
- 4) If controller is equipped with dynamic braking resistors, wire the DBR temperature sensor to the temperature sensor board.
- 5) Add temporary connections on the GALX-1102 Main I/O Board and Expansion I/O boards as shown in Figures 3-1, 3-2, 3-3, and 3-4.



All temporary connections must be removed before placing the elevator in service.

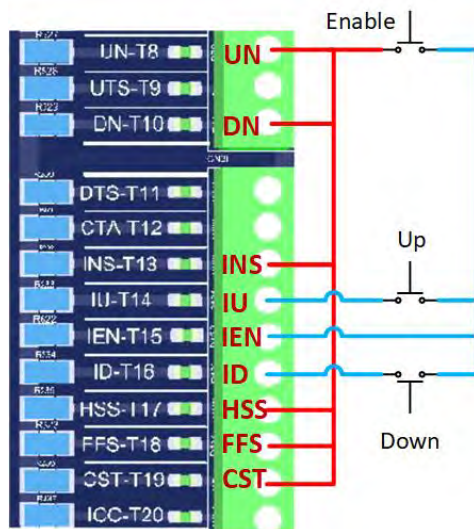

**Figure 3-1: GALX-1102AN Main I/O Board With Run Bug. See Figure 3-4 For Run Bug Stop Switch**

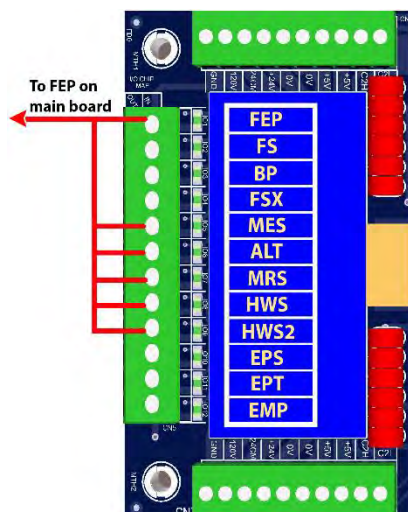

**Figure 3-2: Fire I/O Expansion Board**

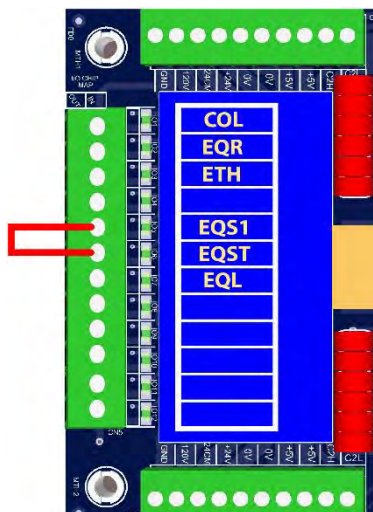

**Figure 3-3: Earthquake I/O Expansion Board (if used)**



- 6) Set the toggles switches on the GALX-1102 Main I/O Board as show in Figure 3-4.

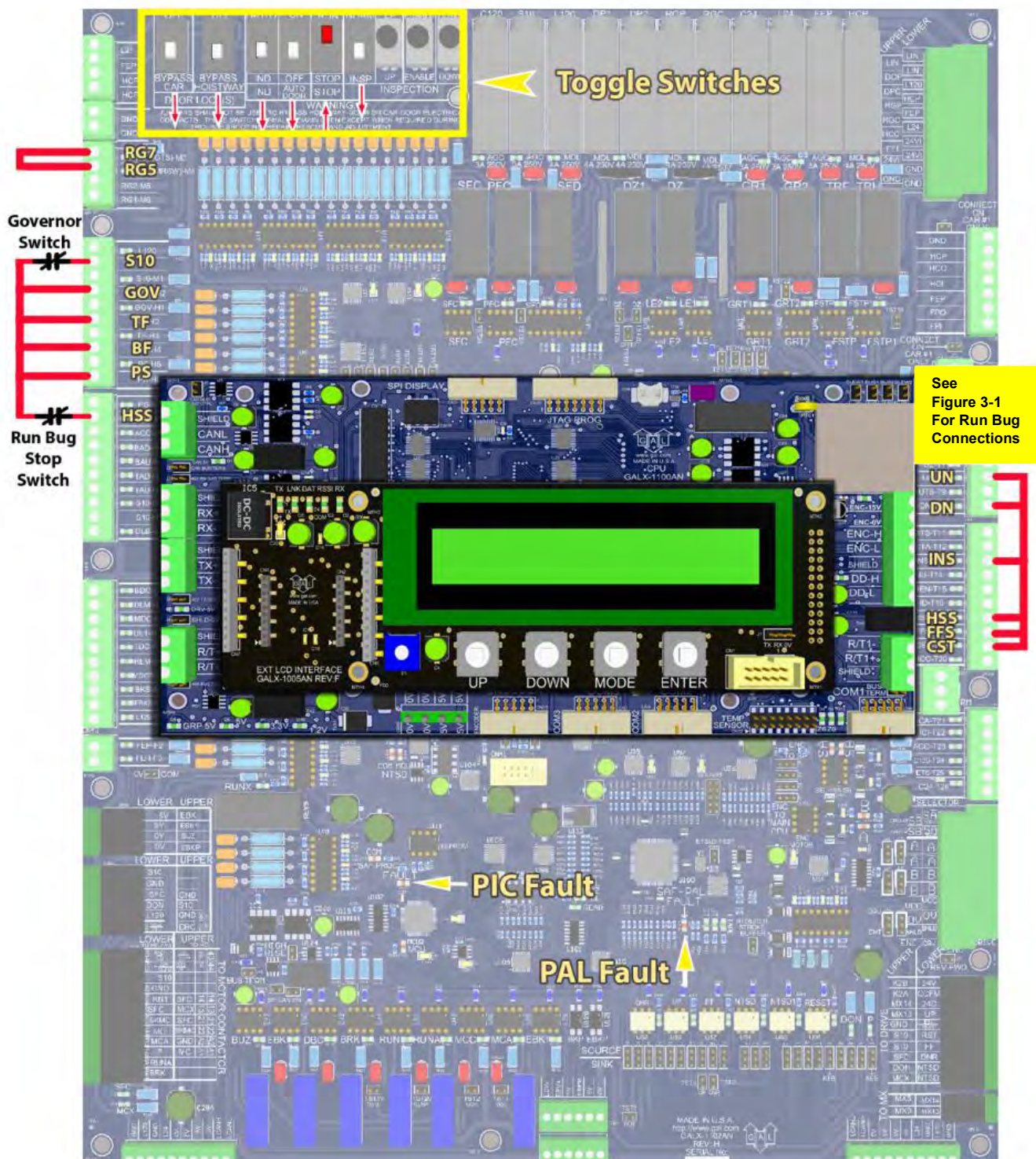

Figure 3-4: GALX-1102AN Main I/O

- 7) Check/set parameters in the controller LCD user interface. See “GALaxy IV Controller Settings” in Table 3-1.

**Preset the following parameters from the LCD User Interface “Adjustable Variables” menu.**

<b>Safety Processor Adjustable Variables Submenu (Motor Encoder Speed Feedback):</b>	
Top Speed (contract speed fpm)	INSP Velocity (set to 140)
Encoder RPM (set to value in drive parameter A1-CONTRACT MTR SPD)	Leveling Vel (set to 140)
Encoder PPR (set to value in drive parameter A1-CONTRACT MTR SPD)	ETS UP VEL (set to Top Speed – only used for reduced stroke buffer)
Encoder Type (set to 4 = incremental)	ETS DOWN VEL (set to Top Speed – only used for reduced stroke buffer)
Control Type (set to 2 = Tract DF)	Soft Stop Time (set to 3)
2 Stop (0 = Multi – Stop; 1 = 2 Stop)	PAL ETS UP Vel (set to Top Speed)
Rear Doors (0 = Front Only; 1 = Rear)	PAL ETS DN Vel (set to Top Speed)
UTS Velocity (set to Top Speed)	
DTS Velocity (set to Top Speed)	
<b>NTS Processor Adjustable Variables Submenu</b>	
Top Speed (contract speed fpm)	DT Velocity (set to Top Speed)
Encoder RPM (set to value in drive parameter A1-CONTRACT MTR SPD)	UT1 Velocity (set to Top Speed)
Encoder PPR (set to value in A1-ENCODER PULSES)	DT1 Velocity (set to Top Speed)
Encoder Type (set to 0 if using APS; set to 1 if using tapeless selector)	UTn Velocity (set to Top Speed)
UT Velocity (set to Top Speed)	DTn Velocity (set to Top Speed)
<b>Car Motion Submenu</b>	
<b>When Using Tapeless Selector:</b>	<b>When Using APS Selector:</b>
Top Speed (set to Contract Speed)	Top Speed (set to Contract Speed)
Inspect Speed (set to 25 FPM)	Inspect Speed (set to 25 FPM)
Encoder PPR (set to 10,000 PPR)	Encoder PPR (not Used)
Encoder RPM (set to governor RPM)	Encoder RPM (not used)
Motor RPM (set to value in drive parameter A1-CONTRACT MTR SPD)	Motor RPM (set to value in drive parameter A1-CONTRACT MTR SPD)
<b>System Options Submenu</b>	
Drive Baud Rate = 0 (19,200)	
Encoder Type = 0	

**Table 3-1: GALaxy IV Controller Settings**

- i** NOTE: For jobs with **Reduced Stroke Buffer**, the parameters associated the ETSLD (Emergency Terminal Speed Limiting Device), must be preset as described below.
- Verify that the Reduced Stroke Buffer jumper is installed on the MAIN I/O board.
  - Verify that the Safety Processor variable Buffer Type is set to 1=Reduced Stroke.
  - To preset the Safety PAL ETS up and down velocity set points, temporarily install the ETSLD Test jumper on the MAIN I/O board.
  - Set the Safety Processor variable ETS Setup Mode to 1=AdjPALets.
  - Preset the following parameters:
    - PAL ETS Up Vel (Set to top speed)
    - PAL ETS Dn Vel (Set to top speed)
  - Remove the ETSLD Test jumper from the MAIN I/O board.
  - Set the ETS Setup Mode parameter to 0=Norm.
  - Leave the Reduced Stroke Main I/O board jumper installed and leave the Safety Processor variable for Buffer Type set for reduced stroke.

**i** NOTE: For governor mounted encoders, to calculate the RPM, divide the contract speed of the car by the distance traveled in one revolution with the governor as shown below:

**RPM = Speed fpm/ (diameter GOV (in feet) \* pi)**

**For a 1 ft. diameter governor: RPM = 350/ (1\*pi) = 350/3.1415 = 111.4**

**For a 16 in diameter governor (16/12 = 1.33ft) : RPM = 350/ (1.33\* 3.1415) = 350/4.188 = 83.5**

Table 3-2 can be used in calculating the governor RPM. For the governor diameter for this project, identify the associated “Divisor” in **red** from Table 3-2. Divide the car speed by the “Divisor” to determine the governor RPM.

Gov. Diameter	Divisor
10"	<b>2.616</b>
11"	<b>2.877</b>
12"	<b>3.141</b>
13"	<b>3.402</b>
14"	<b>3.662</b>
15"	<b>3.926</b>
16"	<b>4.187</b>

**Table 3-2**



The **preset** values entered for the normal terminal limit velocities and the emergency terminal limit velocities are **temporary** settings. These values must be set as described in section 3.3.9 before the elevator is placed into service

- 8) Check/set parameters in the Magnetek M1000 drive. For geared traction with an induction motor see “Magnetek M1000 AC Geared Drive Settings for Start-up” in Table 3-3. For gearless traction with a PMAC gearless motor, see “Magnetek M1000 PMAC Gearless Drive Settings for Startup” in Table and 3-4.

**Preset the following parameters from the M1000 AC Drive dual operator for Geared Machine.**

<b>A1 Drive Submenu</b>	
CONTRACT CAR SPD	= CONTRACT CAR SPEED FT / MIN (OR FPM)
CONTRACT MTR SPD	= MOTOR RPM AT CONTRACT SPEED
ENCODER PULSES	= ENCODER PPR
<b>A4 Power Convert Submenu</b>	
INPUT L-L VOLTS	RMS L-L Applied to Drive
<b>A5 MOTOR Submenu</b>	
MTR RATED POWER	= NAMEPLATE (HP)
MTR RATED VOLTAGE	= NAMEPLATE (VOLTS)
MAX FREQUENCY	=NAMEPLATE (HZ)
MOTOR RATED FLA	= NAMEPLATE (AMPS)
NUMBER OF POLES	= NAMEPLATE VALUE or calculate using the following: number of poles = $[2 * 60 *(excitation\ frequency\ in\ hz) / (rated\ motor\ speed\ in\ rpm)]$
MTR RATED SPEED	= NAMEPLATE (RPM)
<b>U8 Basics Submenu</b>	
CONTROL METHOD	=CLOSED LOOP VECT

**Table 3-3: Magnetek M1000 AC Geared Drive Settings for Start-up**

**Preset the following parameters from the M1000 AC Drive dual operator for PMAC Gearless Machine.**

<b>A1 Drive Submenu</b>	
CONTRACT CAR SPD	= CONTRACT CAR SPEED FT / MIN (OR FPM)
CONTRACT MTR SPD	= MOTOR RPM AT CONTRACT SPEED
ENCODER PULSES	= ENCODER PPR
<b>A4 Power Convert Submenu</b>	
INPUT L-L VOLTS	RMS L-L Applied to Drive
<b>A5 MOTOR Submenu</b>	
PM MTR POWER	= NAMEPLATE (HP)
MTR RATED VOLTAGE	= NAMEPLATE (VOLTS)
MAX FREQUENCY	=NAMEPLATE (HZ)
PM MOTOR RATED FLA	= NAMEPLATE (AMPS)
PM MOTOR POLES	= NAMEPLATE VALUE or calculate using the following: number of poles = $[2 * 60 *(excitation\ frequency\ in\ hz) / (rated\ motor\ speed\ in\ rpm)]$
MTR RATED SPEED	= NAMEPLATE (RPM)
<b>U8 Basics Submenu</b>	
CONTROL METHOD	=PM CLOSEDLOOP VCT

**Table 3-4: Magnetek M1000 PMAC Gearless Drive Settings for Start-up**



NOTE: Other drive parameters have been preset in the factory and may need to be adjusted in the field. See Table 3-6 for additional “Magnetek M1000 AC Geared Drive Settings” and Table 3-7 for additional “Magnetek M1000 PMAC Gearless Drive Settings”.

- 9) Verify the PIC and PAL fault LED's are off. See the GALX-1102AN Main I/O Board in Figure 3-4. If these LED's are on, refer to Section 04 Troubleshooting.
- 10) Verify the settings of the main brake pick and hold voltages as described below.
  - Navigate to the "Adjustable Variables" menu, and "Car Brake" sub menu on the LCD Interface.
  - Set the "Brake Pick Volt", "Brake Hold Volt" and "Brk AC L-L Volt" to the proper values.
  - Verify these voltages at the brake board AC1/AC2/AC3 and BK+/BK- terminals once it is possible to pick the brake.
  - Verify proper operation of the main brake once it is possible to command a run.
- 11) If the elevator uses an emergency brake, verify the emergency brake pick and hold voltages as described below.
  - Navigate to the "Adjustable Variables" menu, and "Car Brake" sub menu on the LCD Interface.
  - Set the "EmBk Pick Volt", "EmBK Hold Volt" and "EMBk L-L VAC" to the proper values.
  - Verify these voltages at the brake board AC1/AC2/AC3 and BK+/BK- terminals once it is possible to pick the brake.
  - Verify proper operation of the emergency brake once it is possible to command a run.



- Verify that the elevator is safe to operate as a running platform and that all individuals are clear of moving machinery.
  - Make sure all hoistway and car doors are closed.
  - If at all possible, place the car in the middle of the hoistway.
- 12) Perform the M1000 AC Drive AUTOTUNE as described below.
    - Set “Inspect Speed” in the “Adjustable Variables Car Motion” submenu to 0.
    - Prevent the main machine brake from lifting.
    - Navigate to the C2-LOGIC INPUT submenu, in the M1000 AC drive dual operator, and set “Term S3 Func Sel” to “Term Not Used”, and set “Term S4 Func Sel” to “Term Not Used”.
    - Navigate to the U9-AUTOTUNE submenu and press “ENTER” on the dual operator.
    - Navigate to “Tuning Mode Select” and press “ENTER” on the dual operator.
    - Navigate to “Tune-No Rotate 1” and press “ENTER” on the dual operator.
    - Press the down arrow key on the dual operator and enter the following motor data.
      - Enter the Motor Nameplate Horsepower and press the down arrow key.
      - Enter the Motor Nameplate Voltage and press the down arrow key.
      - Enter the Motor Nameplate Current and press the down arrow key.
      - Enter the Motor Nameplate Frequency and press the down arrow key.
      - Enter the number of Motor Poles and press the down arrow key.
      - Enter the Nameplate Speed (full load rpm) and press the down arrow key.
      - Enter the Encoder Pulses Per Revolution and press the down arrow key.
      - Enter the Motor No Load Current (if not known, use default setting) and press the down arrow key.

- After entering the parameters above, the dual operator will display “Tuning Ready ?”.
  - Initiate an up or down inspection command until the procedure is complete.
  - While commanding up or down inspection, press “ENTER” on the dual operator.
  - When the procedure is complete, the dual operator will display “END” and “Tune Successful”.
  - Navigate to the C2-LOGIC INPUT submenu and set “Term S3 Func Sel” to “Drive Enable”, and set “Term S4 Func Sel” to “Motor Cont Fdbk”.
  - Set “Inspect Speed” in the “Adjustable Variables Car Motion” submenu to the desired value.
  - Return the main machine brake to its proper operating state.
- 13) **For PMAC Gearless motor**, perform the M1000 Drive “Initial Pole Estimate Procedure” as described below. For geared traction with induction motor proceed to step 15 below.
- Set “Inspect Speed” in the “Adjustable Variables Car Motion” submenu to 0.
  - Prevent the main machine brake from lifting.
  - Navigate to the C2-LOGIC INPUT submenu, in the M1000 AC drive dual operator, and set “Term S3 Func Sel” to “Term Not Used”, and set “Term S4 Func Sel” to “Term Not Used”.
  - Navigate to the U9-AUTOTUNE submenu and press “ENTER” on the dual operator.
  - Navigate to “InitPoleEstPrms” and press “ENTER” on the dual operator.
  - Press the down arrow key on the dual operator, and the dual operator will display “Tuning Ready ?”
  - Initiate an up or down inspection command until the procedure is complete.
  - While commanding up or down inspection, press “ENTER” on the dual operator.
  - When the procedure is complete, the dual operator will display “END” and “Tune Successful”.
  - Navigate to the C2-LOGIC INPUT submenu and set “Term S3 Func Sel” to “Drive Enable”, and set “Term S4 Func Sel” to “Motor Cont Fdbk”.
  - Set “Inspect Speed” in the “Adjustable Variables Car Motion” submenu to the desired value.
  - Return the main machine brake to its proper operating state.
  - After completing a successful “Initial Pole Estimate” procedure, perform the “Pole Position No Rotation” procedure described below.
- 14) **For PMAC Gearless motor**, perform the M1000 Drive “Pole Position No Rotation Procedure” as described below. For geared traction with induction motor proceed to step 15 below.
- Set “Inspect Speed” in the “Adjustable Variables Car Motion” submenu to 0.
  - Prevent the main machine brake from lifting.
  - Navigate to the C2-LOGIC INPUT submenu, in the M1000 AC drive dual operator, and set “Term S3 Func Sel” to “Term Not Used”, and set “Term S4 Func Sel” to “Term Not Used”.
  - Navigate to the U9-AUTOTUNE submenu and press “ENTER” on the dual operator.
  - Navigate to “PolePos-norotate” and press “ENTER” on the dual operator.
  - Press the down arrow key on the dual operator, and the dual operator will display “Tuning Ready ?”
  - Initiate an up or down inspection command until the procedure is complete.
  - While commanding up or down inspection, press “ENTER” on the dual operator.
  - When the procedure is complete, the dual operator will display “END” and “Tune Successful”.
  - Navigate to the C2-LOGIC INPUT submenu and set “Term S3 Func Sel” to “Drive Enable”, and set “Term S4 Func Sel” to “Motor Cont Fdbk”.
  - Set “Inspect Speed” in the “Adjustable Variables Car Motion” submenu to the desired value.
  - Return the main machine brake to its proper operating state.
- 15) Verify that the motor rotation direction and speed are correct. If the motor rotation direction and speed are not correct, perform the procedures describe below to correct the motor rotation direction and speed.

**For PMAC Gearless motor**, perform the following procedure.

- Initiate and up or down inspection command.
- If the motor runs slowly or uncontrolled and draws high current, change parameter C1-ENC 1 ROT DIRECT in the M1000 AC drive to the opposite setting, and perform the “M1000 AC Drive Pole Position No Rotation procedure” again. Verify that the motor rotation direction and speed are correct.
- If the motor speed is correct, but the motor rotates in the wrong direction, change parameter C1-ENC 1 ROT DIRECT in the M1000 AC drive to the opposite setting, change C1-MOTOR ROTATION to the opposite setting, and perform the “M1000 AC Drive Pole Position No Rotation procedure” again. Verify that the motor rotation direction and speed are correct

**For geared traction with an induction motor**, perform the following procedure.

- Run the elevator on inspection.
- If the motor runs slowly or uncontrolled and draws high current, change parameter C1-ENC 1 ROT DIRECT to the opposite setting in the M1000 AC drive. Verify that the motor rotation direction and speed are correct.
- If the motor speed is correct, but the motor rotates in the wrong direction, change parameter C1-ENC 1 ROT DIRECT to the opposite setting, and change C1-MOTOR ROTATION to the opposite setting in the M1000 AC drive. Verify that the motor rotation direction and speed are correct.

### 3.2.2 Check Inspection Speed

---

From the 1005/1101 LCD interface, navigate to the “Adjustable Variables” menu, “Car Motion” and set the “Inspect Speed = 25”.

Run the elevator on inspection and check the speed with a handheld tachometer.

The speed of the elevator should be 25 fpm. If the speed is not 25 fpm, adjust M1000 drive parameter A1 CONTRACT MTR SPD.

### 3.2.3 Complete the Installation of Equipment

---

Before beginning the adjustment process, the installation of all equipment should be completed including the following items. See Section 2 for the installation procedures.

- All field wiring, safety circuits, and safety devices should be installed.
- The APS or Tapeless selector system should be installed including the “door zone bridge” guide clips for the APS selector, or the door zone magnets for the Tapeless selector.
- All Normal and Emergency Terminal limit switches should be installed.
- All car doors and car door electric contacts or car door interlocks should be installed.
- All hoist doors and hoistway door interlocks should be installed.
- The car should be properly counterbalanced.

## 3.3 Adjustment Procedures

---



- Remove all temporary connections.
- Verify that all safety circuits and safety devices are installed and functioning properly.
- Verify that all car door electric contacts or car door interlocks are functioning properly.
- Verify that all hoistway door interlocks are functioning properly.
- Verify that all hoistway doors and car doors are closed.
- Verify that the elevator is safe to operate and that all individuals are clear from moving equipment.

### 3.3.1 Verify Inspection Operation

The car should be ready to run on inspection operation. Select the “Elevator Status” on the 1005/1101 LCD interface. The display should show “Out of Service” on the first line and “Inspection Mode” on the second. Scroll down the “Elevator Status” display until “SPB Vel” is shown. The “Svc=” will display one of the following types of inspection:

- “MR INS” (Machine Room Inspection)
- “CT INS” (Car Top Inspection)
- “ACCESS” (Access Operation)
- “IC INS” (In Car Inspection)
- “AUTO” (Not on Inspection)

The “inspection string” consists of contacts from the inspection switches and the gate and lock bypass switches in series as shown in Figure 3-5. Only one of the five inputs listed above should be on for the car to run.



**NOTE:** Any one of the following conditions will generate an inspection error.

- More than one inspection input is on
- No inspection input is on
- Gate or Lock Bypass switch in the BYPASS position when the car is not on car top inspection

To run the car on machine room inspection, set the machine room inspection switch to the INSP position. Select the “Elevator Status” on the 1005/1101 LCD interface. “MR INS” should be displayed. If the controller is not on machine room inspection, then verify all switch positions and wiring before proceeding

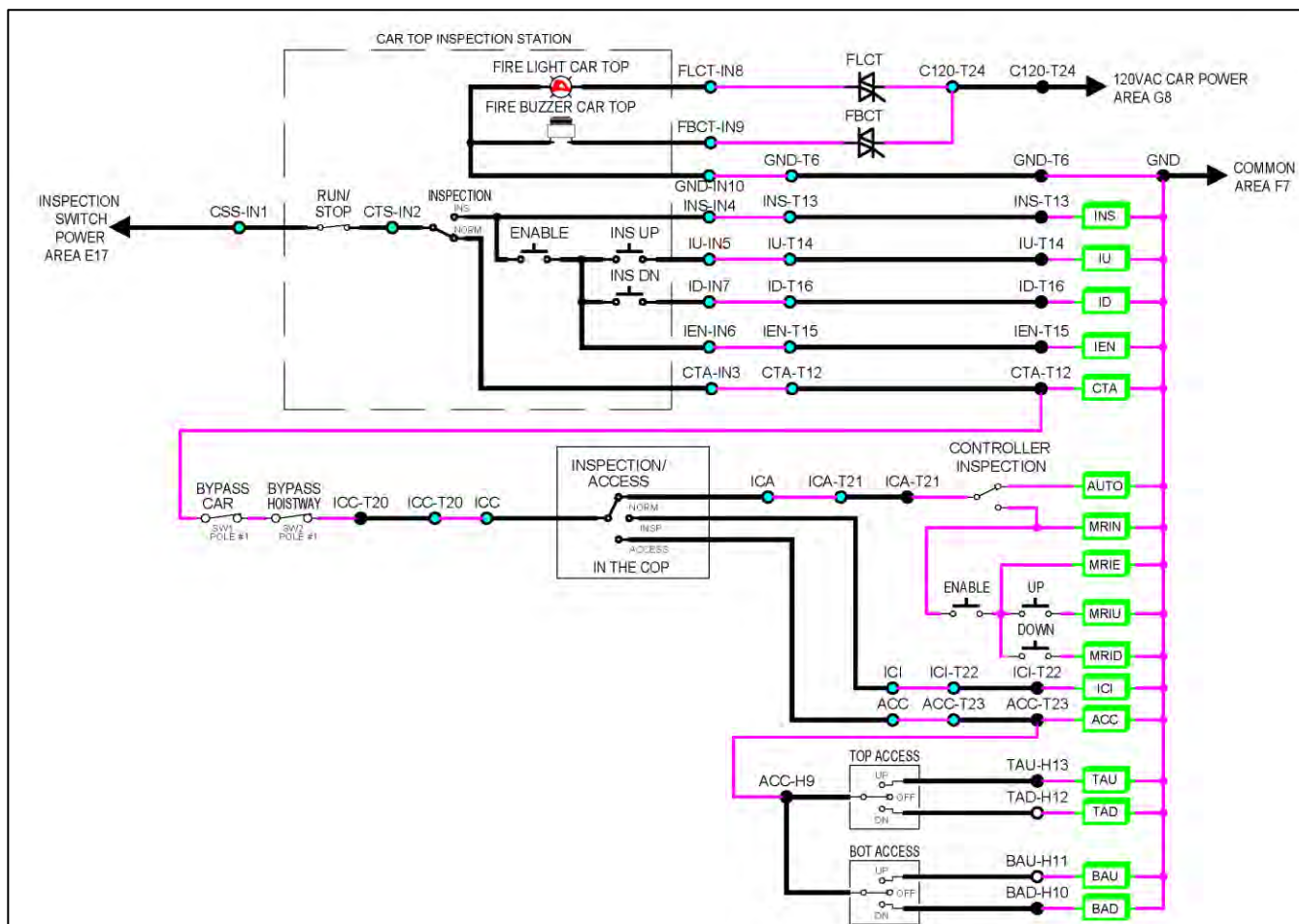

Figure 3-5: Inspection Circuit



### 3.3.2 Verify the Main CPU Velocity Feedback

---

- 1) From the 1005/1101 LCD interface, select the "Elevator Status" menu, and then scroll down or up until the display shows "Dmd" and "Vel". While running on inspection, monitor the controller demand speed "Dmd" and the speed feedback "Vel". These values should both display 25.
- 2) If using an APS selector, the "Dmd" and "Vel" should both display 25 fpm. If "Dmd" and "Vel" do not match, verify the proper installation of the APS selector. See section 2.9.1.3.
- 3) If using a Tapeless selector, verify that the "Dmd" and "Vel" feedback, on the 1005/1101 LCD, both display 25 fpm when the car is running on inspection operation. If "Dmd" and "Vel" do not match, check the Encoder RPM, PPR and TYPE parameters from the "Adjustable Variables" menu, and verify that these parameters are set properly. If the Encoder PPR and Type are set properly, the Encoder RPM value may need to be adjusted incrementally until the "Vel" matches the "Dmd" at 25 fpm (within +/- 2 fpm), when the car is running on inspection operation.
- 4) If the "Dmd" speed, the "Vel" speed, and the handheld tachometer (see section 3.2.2) speed all display 25 fpm when the car is running on inspection, proceed to section 3.3.3. If not, contact GAL Technical Support.

### 3.3.3 Verify the Encoder Direction for the Main CPU

---

- 1) From the LCD interface "Elevator Status" menu, scroll down or up to display "Dir" and "DP". While moving the car on inspection, monitor "Dir" (direction) and "DP" (pulse counts). "Dir" should display "Up" when the car is moving up, and "Dn" when the car is moving down. The value of "DP" should increment when the car is moving up and should decrement when the car is moving down.
- 2) If using an APS selector, the "Dir" should display "Up" when the car is moving up and "Dn" when the car is moving down. The value of "DP" should increment when the car is moving up and should decrement when the car is moving down. If the direction is incorrect or the pulse counts change in the wrong direction, the APS selector should be verified for proper installation. See section 2.9.1.3.
- 3) If using a Tapeless selector, the the "Dir" should display "Up" when the car is moving up and "Dn" when the car is moving down. The value of "DP" should increment when the car is moving up and should decrement when the car is moving down. If the direction is incorrect or the pulse counts change in the wrong direction, then the encoder direction to the controller must be changed. From the 1005/1101 LCD Interface, navigate to the "Adjustable Variables" menu, "Car Motion" and set the "Encoder Dir = 1" if already 0 or set to 0 if already 1. The car may get an unintended motion fault (gripper fault) when the parameter is changed. If so, then reset the unintended motion fault from the "Reset / View Faults" menu, "Reset Gripper / EBK Fault" submenu.

### 3.3.4 Match Feedback Velocity and Direction

---

- 1) Place the car on machine room inspection and position the car in the middle of the hoistway.
- 2) In the "Adjustable Variables", "Car Motion" submenu, set the "Inspect Speed" parameter to 50 fpm.
- 3) Navigate to the "Elevator Setup", "Match Feedback Vel & Dir" menu and press Enter.
- 4) Follow the instructions on the LCD interface. See section 5.2.43, Figure 5-43

### 3.3.5 Verify Safety Processor Velocity and Direction Feedback

---

- 1) After completing the “Match Feedback Vel & Dir” procedures in section 3.3.4, verify that the secondary velocity and direction feedback from the Safety Processor are correct.
- 2) From the 1005/1101 LCD interface, select the "Elevator Status" menu and then scroll down or up until the display shows "SPB Vel". The direction will show as a “U” or “D” next to the car speed. The speed displayed should match the car’s actual speed, and the displayed direction should match the car’s direction.
- 3) If the “SPB Vel” is not correct, increment or decrement the value of “Encoder RPM” in the “Safety Proc Adj Vars” submenu, until the “SPB Vel” is correct.
- 4) If the displayed direction is not correct, change the setting of “Encoder Dir” parameter in the “Safety Proc Adj Vars” submenu. If the parameter is 0, then set it to 1. If the parameter is 1, then set it to 0.

### 3.3.6 Verify NTS Processor Velocity and Direction Feedback

---

- 1) After completing the “Match Feedback Vel & Dir” procedures in section 3.3.4, verify that the third velocity and direction feedback from the NTS Processor are correct.
- 2) From the 1005/1101 LCD interface, select the "Elevator Status" menu and then scroll up or down until the display shows "NTS Vel". The direction will show as a “U” or “D” next to the car speed. The speed displayed, should match the car’s actual speed, and the direction should match the car’s direction.
- 3) If using a Tapeless Selector and the “NTS Vel” is not correct, increment or decrement the value of “Encoder RPM” in the “NTS Proc Adj Vars” sub menu, until the “NTS Vel” is correct. If using an APS selector, the “NTS Vel” should be correct. If the “NTS Vel” is not correct, verify the proper installation of the APS selector. See section 2.9.1.3.
- 4) If using a Tapeless Selector and the displayed direction is not correct, change the setting of the “Velocity Dir” parameter in the “NTS Proc Adj Vars” sub menu. If the parameter is 0, then set it to 1. If the parameter is 1, then set it to 0. If using an APS selector, the displayed direction should be correct. If the displayed direction is not correct, verify the proper installation of the APS selector. See section 2.9.1.3.

### 3.3.7 Hoistway Learn Procedure

---



If using an APS selector, return to section 2.9.1.3, “Verify that the APS Selector is Installed Correctly and Communicating”. Complete sections 2.9.1.3 through 2.9.1.6, “Setting Hoistway Floor Levels with APS Selector”. After completing section 2.9.1.6, return to this section, 3.3.7, and proceed to step 1 below.



If using a Tapeless selector, proceed to step 1 below.

- 1) Verify that the “UL”, “DL” and “DZ” inputs are functioning properly.
  - As the car approaches a floor level in the up direction, the “UL” input should turn on first, the “DZ” input should turn on second, and the “DL” input should turn on third.
  - As the car approaches a floor in the down direction, the “DL” input should turn on first, the “DZ” input should turn on second, and the “DL” input should turn on third.

- 2) Verify that the normal limits are functioning properly.
  - The “UN” input should turn off and stop the car in the up direction when the car is approximately 2 inches above the top terminal landing.
  - The “DN” input should turn off and stop the car in the down direction when the car is approximately 2 inches below the bottom terminal landing.
- 3) Verify that the limits at the terminal landings are functioning properly as the car approaches and leaves the terminal landings. See Table 2-1, “Slowdown Distances from Terminal Landings”, and the job schematics, for the limits required for a specific elevator.
  - As the car approaches the terminal landings the inputs for the limits should turn **OFF** in the correct sequence.
  - As the car leaves the terminal landings the inputs for the limits should turn **ON** in the correct sequence.
- 4) If using an APS selector, proceed to section 3.3.8, “Adjust the Elevator”.
- 5) If using a Tapeless selector, run the car down on inspection until it stops on the down normal limit. Verify that the “DN and DL” input LED’s are both off and that the “UL” and “DZ” LED’s are on.
- 6) Navigate to the “Elevator Setup” menu, “Learn Hoistway” submenu. The learn procedure can be performed automatically by selecting “Auto” from the menu items or performed manually by choosing “Insp” from the menu items. After choosing the learn method, follow the instructions displayed on the LCD interface. See section 5.2.44.1, “Learn Hoistway for Tapeless Selector”
  - In general, the car will run up from the “down normal limit” to the “up normal limit” at 30 fpm (this speed is fixed and cannot be changed). During this learn run, the DP count for each floor level and each limit switch will be stored in memory.
  -  **NOTE:** The car must run the entire hoistway without stopping.
  - When the elevator starts a hoistway learn, the display will change to show the car velocity and the position count. Verify that the position count is incrementing as the elevator moves up. Also, as the elevator passes each floor, the pulse count and distance for that floor should change and be stored. The pulse count for the terminal slowdowns will also be stored. The elevator will stop when it reaches the up normal limit.
- 7) Follow the instructions on the LCD interface by placing the car on inspection. The LCD will display “Hoistway Learn Complete”.

### 3.3.8 Adjust the Elevator

---



- Prepare the elevator to move on automatic operation.
- Verify that the “AUTO DOOR” switch is in the “OFF” position
- Verify that the machine room independent switch is set to the “IND” position.
- Verify that the elevator is safe to operate and that all individuals are clear from moving equipment.
- Verify that the elevator is secured from the general public.

#### 3.3.8.1 Automatic Run

---

- 1) Move the elevator on inspection until the “DZ” and “DL LEDs are on. Set the machine room inspection switch to the “NORM” position. The elevator should level down to floor level.
- 2) The elevator should now be idle at floor level and ready for an automatic run. The default parameter settings for the ride quality should be adequate for an initial run. From the 1005/1101 LCD interface, navigate to the "Set Calls and Lockouts" menu, "Setup Car Calls" submenu, and enter a car call. The elevator should run to answer the call. When the elevator levels in and stops at the floor, the doors will remain closed. At this point the acceleration and deceleration of the car should be smooth and stepless regardless of the distance of run.
- 3) Verify the high speed of the car, by making high speed runs while observing the “Elevator Speed” on the “Home” screen of the drive’s LCD display. The speed displayed on the drive should match the speed displayed on the 1005/1101 LCD interface, "Elevator Status" menu, "Dmd" and "Vel". This speed should also match the speed displayed on for the safety processor display "SPB Vel" and the NTS Processor “NTS Vel” (within +/- 2 fpm).
- 4) If the speed is slightly under or over contract speed, adjust the speed by changing the M1000 drive parameter A1 CONTRACT MTR SPD. If the A1 CONTRACT MTR SPD parameter is changed, re-verify the Main CPU velocity, the Safety Processor velocity, and the NTS processor velocity are correct. If these velocities are not correct, see sections 3.3.2, 3.3.5, and 3.3.6 for adjustment procedures.

#### 3.3.8.2 Fine Tune the Ride Quality

---

The main CPU provides a digital speed command, or S-curve profile, to the drive, and the drive controls the motor speed and torque in order to move the elevator at the commanded speed. The default controller and drive parameters should provide a smooth elevator ride quality with a moderate floor-to-floor performance time. For a more aggressive floor-to-floor performance time, adjustments can be made to the S-curve parameters in the “Adjustable Variables”, “Car Motion” sub menu.

Figure 3-6 shows a typical graph of the elevator’s S-curve profile. The S-curve parameters are listed on the graph within the portion of the S-curve controlled by the specific parameter. In general, the elevator’s floor-to-floor time can be changed by changing the value of the following parameters.

- Soft Start Jerk: Increase value to decrease floor-to-floor time
- Acceleration: Increase value to decrease floor-to-floor time
- Roll Over Jerk: Increase value to decrease floor-to-floor time
- Decel Jerk: Increase value to decrease floor-to-floor time
- Deceleration: Increase value to decrease floor-to-floor time
- Floor Targ Dis: Decrease value to decrease floor-to-floor time

As the S-curve parameters are adjusted to decrease the floor-to-floor time, the response and inertia values in the Quattro drive may need to be increased so that the drive will respond properly to the more aggressive speed command from the main CPU. In general, higher response and inertia values make the drive more responsive and lower response and lower inertia values make the drive less responsive. As the drive becomes more responsive, it will cause the motor to follow the S-curve more closely.

The response and inertia values in the M1000 drive can be increased by increasing the values of the following drive parameters.

- A1 RESPONSE
- A1 INERTIA

Increasing the response and inertia too much, may cause vibrations and audible noise in the motor.

If the car spots when approaching the floor, the cause is usually due to the car not tracking (the drive response is set too low) or the speed profile into the floor is too aggressive. First try to increase the response of the drive.

If the car still spots, increase the floor targeting distance and retest the ride. The default value for the floor targeting distance is 12 inches. Increase it by steps of 2 or 3 and continue retesting until the parameter is adjusted to 18. If no change is noticed, start again from 12 and decrease the value. The deceleration rate can also be reduced to help remove the spotting.

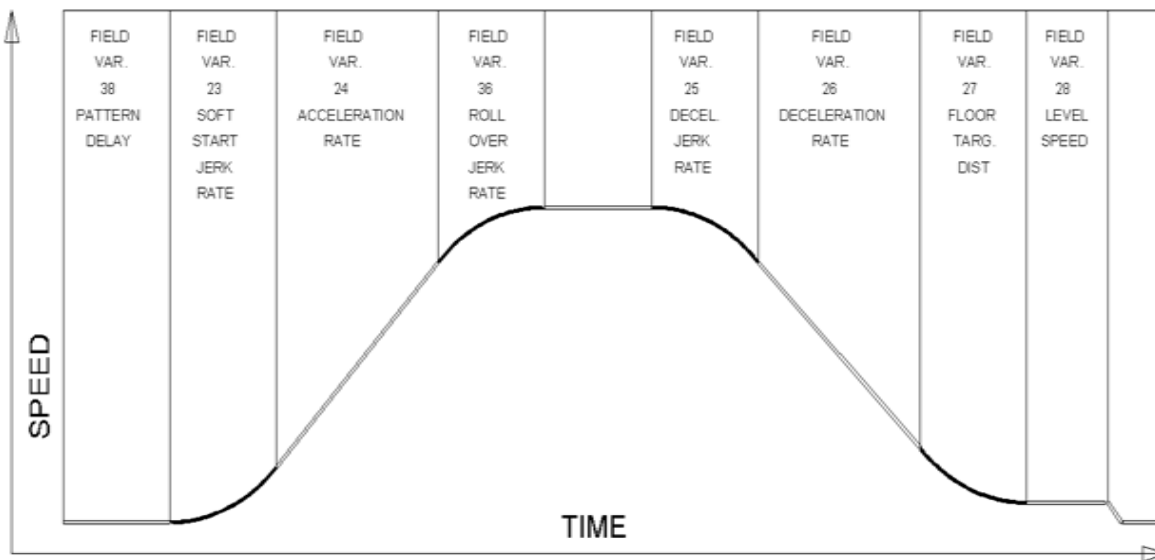

Figure 3-6: S-curve Profile

### 3.3.8.3 Adjust the Stop

---

When at floor level the “UL, DL, & DZ” input LEDs should be on. If the elevator continually tries to seek floor level by re-leveling up and down, try the following steps to correct the problem:

- Increase the overall response of the drive by increasing the value of A1 RESPONSE in the M1000 drive.
- Increase the response of the drive at leveling and re-leveling speeds by increasing the A1 INNERLOOP XOVER parameter.
- Reduce the leveling and re-leveling velocity parameters from the 1005/1101 LCD interface "Adjustable Variables" menu, "Car Motion", "Leveling Speed" and "Relevel Speed".
- If the car still oscillates, adjust the "floor level zone" on the selector.

For a Tapeless selector, the "floor level zone" is increased by moving the "UL" and "DL" sensors closer together.

For an APS selector, the “floor level zone” is increased by increasing the value of the “APS Dead Zone” parameter in the “Adjustable Variables”, “Car Motion” submenu in the 1005/1101 LCD interface.

To fine tune the floor level accuracy, determine if the controller is set to stop when "UL" and "DL" signals turn on, or if controller is set to stop off of a combination of the “UL” and “DL” signals and the position count. From the 1005/1101 LCD interface, navigate to the "Adjustable Variables" menu, "Car Motion" and view the "Stop On Pos Cnt" variable. If "Stop On Pos Cnt = 0", then the controller is set to stop when the "UL" and "DL" signals turn on. If "Stop On Pos Cnt = 1", then the controller is set to stop on a combination of the “UL” and “DL” signals and the position count.

With a Tapeless selector and with "Stop On Pos Cnt = 0", the floor levels should be set by accurately setting the floor level magnet at each floor. For proper operation, the floor magnets should be set to exactly floor level. After the floor levels are set properly, perform another hoistway learn procedure.

With an APS selector and with "Stop On Pos Cnt = 0", the floor levels should be set by accurately recording the floor position when using an APS selector.

If the “floor level zone” needs to be increased to prevent “nuisance” re-leveling, the floor level accuracy can be maintained by setting the “Stop on Pos Cnt =1” and performing the following adjustments. From the 1005/1101 LCD interface, navigate to the "Hoistway Tables" menu, "DZ & LZ Offset, Sel Cnt" and adjust "Dn Lev Dist" and "Up Lev Dist". The units for these variables are in "pulse counts". With "Stop On Pos Cnt =1" the car will continue to move for the "Dn Lev Dist" or "Up Lev Dist" after "UL" and “DL” turn on. Use the "Dn Lev Dist" and the "Up Lev Dist" parameters to make level changes at all floors. To make level changes at individual floors, perform the following adjustments. From the 1005/1101 LCD interface, navigate to the "Hoistway Tables" menu, "FL and FL Offset Count", and the offset count can be adjusted. These variables introduce an offset (+/-) to the stored floor count that was determined in the hoistway learn procedure.



NOTE: The number of pulse counts per inch can be viewed from the 1005/1101 LCD interface, "Hoistway Tables", "DZ & LZ Offset, Sel Cnt", "Pulses / Inch".



NOTE: For a Tapeless selector the floor magnet must be set properly at floor level, and for an APS selector the floor level must be accurately recorded. If too large of values are entered into "Dn Lev Dist", "Up Lev Dist", or "Offset", this will cause the car to drive past the floor and re-level.

If the car stops hard on the brake, then make the following adjustments. From the 1005/1101 LCD interface navigate to the "Adjustable Variables" menu, "Car Motion", and adjust both "Brake Drop Del" (brake drop delay) and "Soft Stop Time". These variables should be adjusted so that zero speed is observed at the end of the run prior to the brake setting. The controller should hold the car at zero speed for the duration of the "Soft Stop Time" which should continue while the brake is setting and for a short time after the brake sets.

The soft stop time MUST be set to at least 1.2 seconds LONGER than the brake drop delay. The "Soft Stop Time" setting in the 1005/1101 LCD interface should be compared with the setting in the "Safety Proc Adj Vars" menu, "Soft Stop Time". The setting of "Soft Stop Time" in the Safety Processor should be greater than the "Soft Stop Time" setting in the main CPU. A typical setting for the Safety Processor soft stop time is 3 seconds.

After the "Soft Stop Time" expires, the drive will ramp the motor torque down to zero, and the load will be transferred to the main brake. The M1000 drive parameter, A1 TrqLmtRedTim@Stp, can be adjusted to allow the torque to be gradually reduced after the "Soft Stop Time" has expired. Also, the "MC Drop Dly Tim" should be set to allow the MC contactor to de-energize after the A1 TrqLmtRedTim@Stp has expired.

#### 3.3.8.4 Adjust the Start

---

To provide a proper start, from the 1005/1101 LCD interface, navigate to the "Adjustable Variables" menu, "Car Motion" and adjust "Brake Pick Del" (brake pick delay), "Pattern Delay", and "Soft Start Jerk". Initially, set the brake pick delay to 0 and increase the pattern delay by 0.1 seconds until the controller picks the brake completely before the motor starts to move. If roll back occurs, then reduce the pattern delay until there is no roll back. Sometimes, the timing works out better if the brake pick delay is set to 0.1 second.

In order to provide a smooth start with no roll back and without feeling the car move under the brake, it may be necessary to utilize the motor pre-torque feature. There are two pre-torque options. The first option is using a load weigher device described in sections 3.3.8.5 through 3.3.8.9. The second option is using the M1000 "Position Lock" feature described in section 3.3.8.10.

After the adjustments have been made to provide a proper start, the car will start smoothly, with no roll back, and without feeling the brake. The "Soft Start Jerk" parameter can now be increased to provide a quicker transition from start to constant acceleration. Keep in mind that the larger the soft start number, the quicker the start. The ride should now be acceptable.

#### 3.3.8.5 Load Weigher Setup

---

Install, wire, and calibrate the load weigher as described by the load weigher manufacturer. The wiring of the load weigher is shown in the job schematics and connection diagrams.

Verify that the load weighing device is communicating to the main CPU by performing the following steps. From the 1005/1101 LCD interface, navigate to the "Diagnostics" menu, "Car Can Comm Status", "Car CTCAN to LW BD" and verify that "On-line = 1". If "On-line = 0" then verify wiring and installation of load weighing device.

### 3.3.8.6 Empty Car Setup for Load Weigher

---

From the 1005/1101 LCD interface, navigate to the "Elevator Setup" menu, "Load Weigher Setup", "Setup Load Weigher" and follow the instructions on the display as you go through the procedure. It is okay to exit the setup screen to place a call and then return to it while the setup is being performed.

Run the car to the bottom floor and press Enter on the 1005/1101 LCD interface, when prompted to do so, to start the automatic load weigher setup sequence. When the automatic sequence is activated, the car will run to each floor and measure the empty load value. The 1005/1101 LCD interface will indicate when the sequence is finished.

### 3.3.8.7 Full Load Setup for Load Weigher

---

**The empty car setup must be successfully completed to run the full load setup.**

Once the empty car setup is complete, run to the loading floor and set the "AUTO DOOR" switch to the "ON" position to allow weights to be loaded on the car. With the car fully loaded, set the "AUTO DOOR" switch to the "OFF" position and run the car to the bottom floor.

With the car at the bottom floor, follow the instructions on the 1005/1101 LCD interface to start the full load setup sequence. The car will automatically run to each floor and measure the full load value. When the full load measurement is complete, the car can be run to the loading floor and the weights removed.

After the weights are removed, cycle the doors to complete the procedure. From the 1005/1101 LCD interface, navigate to the "Elevator Setup" menu, "Load Weigher Setup", "View/Modify LW Setup" and verify the load weigher status, "LW Device Stat: ON OK". If the status is "ON OK", then the load weigher should be accurately measuring the car load in real time. The percent load will be displayed, "Load: \_%".

The percent load values for different service options can now be set. From the 1005/1101 LCD interface, navigate to the "Adjustable Variables" menu, "Service Options", and set the following variables:

- "Load Bypass"
- "Load Antinuisance"
- "Load Dispatch"
- "Load Overload"



NOTE: Setting the values of the variables above to 0% will disable that particular option.

### 3.3.8.8 Load Weigher Calibration Sequence

---

The load weigher is automatically calibrated once each week. If an error is detected during this calibration sequence, the load weigher and the pre-torque feature (if used) is disabled.

A load weighing calibration sequence can be manually activated by performing the following procedure. From the 1005/1101 LCD interface, navigate to the "Elevator Setup" menu, "Load Weigher Setup", "Load Weigher Calibration" and follow the instructions on the display.



### 3.3.8.9 Adjust Load Weigher Pretorque

---



NOTE: The motor pre-torque uses the load value obtained from the analog load weigher and will only work if the load weigher has been installed properly, and the "Load Weigher Setup" has been performed successfully.

On the M1000 drive set C1 Trq Comp Cmd Src to "Serial HPV". This will enable drive to accept the pre-torque signal from the controller. Set C5 Term A2 FuncSel to "Torque Comp".

Run the empty car to a middle floor. From the 1005/1101 LCD user interface, navigate to the "Adjustable Variables" menu, "Car Motion" and adjust the following parameters to the initial values listed:

- "Balanced Load = 40" (typically car is 40% counterbalanced, but verify counterbalance percentage for each specific job)
- "Torque Amount = 10"
- "Pattern Delay = 2.5"
- "Torque Ramp Tim = 0"
- "DON Start Ctrl = 1"
- "Brake Pick Del = 0.1"

The initial value of "Pattern Delay = 2.5", will allow roll back to be observed at the start of a run. Make a one floor run down and observe the roll back when the brake picks at the start of the run. Increase the "Torque Amount" variable and continue to monitor the roll back while performing one floor runs in the down direction. As the "Torque Amount" is increased, the roll back should be minimized until the drive holds the motor at zero speed for the entire "Pattern Delay" time. A typical value for the "Torque Amount" is 60%. If the value is too large, the car will roll forward during the "Pattern Delay" time.

The advanced pre-torque "Adv Pre-torque" parameter can be set to 1 on the controller "Car Motion", "Adjustable Variables" menu to allow the motor contactor to pick and the drive to pre-torque the motor when the door DPM limit turns on during the door close cycle.

If the "Torque Amount" on a down run requires a different value than a run up, setting the "Torque Down Amt" to a non-zero value separates the two adjustments. The "Torque Amount" becomes the torque amount on an up run and the "Torque Down Amt" on a down run.

After adjusting the pre-torque, the "Pattern Delay" timer should be re-adjusted to a value that allows the drive to hold the motor at zero speed momentarily after the main brake picks at the start of a run. If the "Pattern Delay" timer expires too soon, the motor will try to move before the brake picks. If the "Pattern Delay" timer is too long, the floor-to-floor flight time will be increased.



NOTE: The pattern delay must be at least 0.15 seconds (150 milliseconds). Setting the torque amount to 0.00 will disable the pre-torque feature. Also, if the load weighing calibration sequence detects a load weighing error, the pre-torque feature is automatically disabled.

### 3.3.8.1 Adjust Position Lock

---

Position Lock Operation can be used to prevent rollback on start without using a load weigher. To setup Position Lock, place the empty car in the middle of the hoistway so that during test the car does not end up on the finals.

Set the controller “Inspect Speed” = 0 and preset the following parameters in the drive:

- A1 SpCtrlGn@PosLck = 20.00 (IM) or 5.00 (PM)
- A1 SpCtrlTim@PosLck = 0.100
- A1 DC Brk TimeStart = 1.00
- A1 StrPosLckGain 1 = 5
- A1 StrPosLckGain 2 = 0.00

To Enable Position Lock set the following parameters in the drive.

- C1 Trq Comp Cmd Src = “Analog”
- C5 Term A2 FuncSel = “Not Used”

The A1 DC BRK TimeStart parameter should be set to approximately the same amount of time that the rollback occurs. From the 1005/1101 LCD user interface, navigate to the "Adjustable Variables" menu, "Car Motion" and set “Pattern Delay = 1.5”.



The motor will not acknowledge a speed reference until the A1 DC Brk TimeStart has expired.

Increase A1 StrPosLckGain 1 by increments of 5 until the rollback is removed. If you reach the maximum value and still have roll back or if the motor vibrates or oscillates, set the A1 StrPosLckGain 1 to 5 and increase the A1 StrPosLckGain 2 by increments of 5 until the rollback is removed.



If the motor starts to vibrate or make noise during Position Lock operation, lower both the A1 SpCtrlGn@PosLck and A1 SpCtrlTime@PosLck by increments of 5 until the vibration or noise is eliminated.

To fine tune the position lock, slowly lower the A1 DC Brk TimeStart to the smallest value before the rollback starts to reappear. Set the controller “Pattern Delay” 0.3 seconds less than the value of the A1 DC Brk TimeStart value. If the A1 DC Brk TimeStart = 0.9 seconds then set the “Pattern Delay” to 0.6 seconds.

### 3.3.9 Adjust Safety Processor, NTS Processor, and Main CPU Limit Velocity Speed Clamps

---

The Safety Processor, a processor chip located on the 1102 Main I/O board, monitors the speed of the elevator at the terminal landings independently from the main CPU. When the “UTS, DTS and ETS” limit switches are activated, the Safety Processor calculates the velocity of the elevator and compares that velocity with a stored velocity for each limit. If the velocity, when the switch activates, is greater than the limit velocity value, then the Safety Processor will generate a fault that stops the elevator by removing power from the driving machine and brake.

The ETS limit activates at both the top and bottom terminal locations to verify the UTS and DTS limits when reduced stroke buffer is used.

The NTS Processor monitors the velocity of the car and all the Normal Terminal Slowdown Limits from the selector on a separate serial CAN bus. If a normal terminal limit is activated and the car is traveling

faster than the limit velocity set point for that limit, the NTS processor will turn off the NTSD output to the drive causing the drive to initiate a timed emergency slowdown independent of the Main CPU speed profile and the Safety Processor.

The deceleration rate, jerk rate, and target speed are set by the M1000 drive parameters. After an emergency slowdown is initiated the car reaches the target speed, the car will continue at that speed until the terminal landing door zone or the normal limit is reached. If the command speed of the controller goes below the target speed, the drive will follow the command speed. Before testing the NTS operation, set the initial values for the drive as shown below to be certain that the car will slow down fast enough to stop at the terminal landing:

- A2 NTSD Decel Rate = 6 ft/sec<sup>2</sup>
- A2 NTSD DecJrkStart = 12 ft/sec<sup>3</sup>
- A2 NTSD DecelJrkEnd = 12 ft/sec<sup>3</sup>
- A1 NTSD Speed = 10 fpm
- C1 NTSD Mode = External - Input
- C2 Term S7 Func Sel = Not in NTSD

Once the slowdown operation is verified, the drive parameters can be decreased to allow for a smoother stop.

The Main CPU also monitors the speed of the car independently of the speed profile. It also checks the Normal Terminal Slowdown limits and Emergency Terminal Slowdown limits for the correct location in the hoistway and will clamp the speed profile at each terminal limit. If a limit is activated at a position that is not consistent with the learned value, the Main CPU will initiate a timed deceleration pattern at the “Em Decel Rate” until the “Recovery Speed” is reached. When the car reaches a door zone, it will decelerate at the “Em Decel Lev” rate and then stop level at the floor. If the velocity of the elevator is greater than the limit velocity set point when a limit is activated, the Main CPU will clamp the speed profile velocity value to the set point value (clamp value). The normal and emergency slowdown positions are learned during the hoistway learn procedure.

### 3.3.9.1 Learn the Safety Processor, NTS Processor, and Main CPU Limit Velocity Speed Clamps

---

To setup the limit velocity set point values for all three devices, navigate to the “Elevator Setup” menu on the 1005/1101 LCD interface and select the “Learn Limit Velocities” menu. Follow the directions on the screen to preset the limit values, set the car on independent with automatic doors turned off and then run the Learn Limit procedure.

The elevator will run to the top landing and then run one floor down, delay a short time, run back to the top floor and then record the limit velocities. The elevator will then run two floors down and again return to the top floor to record the values. The car will continue to increase the number floors to run down and the again run up until contract speed is reached. After learning the velocities for all the limits in the up direction, the car will then do the same procedure to the bottom floor to learn the velocities for the limits in the down direction.

Once the down direction limit velocities are learned, all the limit velocity values will be stored in memory. After a successful “learn” process, the 1005/1101 LCD display will show “Limit Velocity Learn Complete”.

Verify that the values learned and stored for the following parameters are valid.

- “Safety Proc Adj Vars” menu
    - UTS Velocity
    - DTS Velocity
    - ETU Velocity (if used)
    - ETD Velocity (if used)
  - “NTS Proc Adj Vars” menu
    - UT Velocity
    - DT Velocity
    - UT1 Velocity (if used)
    - DT1 Velocity (if used)

Continue verifying the values for each “UTn Velocity” and “DTn Velocity” for the number of “n” limits as determined by the car speed.
  - “Elevator Setup” menu, “Set DT/UT Slowdown Clamp”
  - “Elevator Setup” menu, “Set DT1/UT1 Slowdown Clamp” (if used)
- Continue verifying the values for “Elevator Setup” menu, “Set DTn/UTn Slowdown Clamp” the number of “n” limits as determined by the car speed.

If the process fails or is interrupted, the display will show “Limit Velocity Learn Failed” or “Limit Velocity Learn Interrupted”. A limit learn failure would be the result of the following conditions.

- The car did not reach contract speed during a run.
- The limits switches are set too far from the terminal landing.
- A fault occurred during the learn process.

If the learn was not successful, check the fault log for faults and make the necessary corrections.

### 3.3.9.2 Manually Adjust the Safety Processor and NTS Processor Limit Velocity Speed Clamps

---

An alternate method for manually setting the Safety Processor and NTS Processor Limit Velocity Speed Clamps is detailed below.

To manually set the speed clamps on the Safety processor and NTS processor, make a one floor run to the top floor. After the car stops, record the velocity that the car actuates the “UTS” and “ETS” slowdown limits for the safety processor, and the “UT, UT1, UT2 ... UTn” limits for the NTS processor.

“ETS” top and bottom limits are used on cars with reduced stroke buffers.

The velocity values are shown from the “Elevator Status” menu on the 1005/1101 LCD interface as “UTSvel”, “DTSvel”, “ETUvel”, “ETDvel”, “UT Vel”, “DT Vel”, “UT1Vel”, “DT1Vel” ... “UTnVel” and “DTnVel”.

The single input “ETS” is used when the limit is activated at the top or bottom limit as a secondary check for UTS and DTS. When the car is at the top of the hoistway and ETS is actuated, the velocity is shown as “ETUvel” and when the car is at the bottom of the hoistway and ETS is actuated, the velocity is shown as “ETDvel”.

Run the car again to the top repeatedly from 2 floors down, then 3 floors down, etc., until top speed is reached. Record the limit velocities displayed each time the car stops at the top floor.

Make the same runs to the bottom floor starting from 1 floor, then 2 floors, then 3 floors, etc., until top

speed is reached. Again, use the “Elevator Status” menu on the 1005/1101 LCD interface to record the displayed limit velocities for “DTS and ETS” for the Safety processor and the “DT, DT1, DT2 ... DTn” limits for the NTS processor. Do this each time the car stops at the bottom floor.

Take the highest speed value recorded in the runs to the top and bottom floors and add 10 fpm or 5% (whichever is larger) to that value to use as the clamp speed values for the respective limits.

Enter the clamp speed values for the Safety Processor. From the 1005/1101 LCD interface, select the "Adjustable Variables" menu, then the "Safety Proc Adj Vars" menu and then enter the values for parameters “UTS Velocity”, "DTS Velocity", "ETU Velocity" (ETS at the top) and "ETD Velocity" (ETS at the bottom) respectively.

Also, enter the clamp speed values for the NTS Processor. From the 1005/1101 LCD interface, select the "Adjustable Variables" menu, then the "NTS Proc Adj Vars" menu and then enter the values for parameters “UT Velocity”, "DT Velocity", "UT1 Velocity", "DT1 Velocity" ... “UTn Velocity” and “DTn Velocity” respectively.

**3.3.9.3 Manually Adjust the Main CPU's Limit Velocity Speed Clamps**

---

Having just made several runs into the top and bottom landings, the main CPU has also recorded the car’s velocity when the slowdown limits were activated. If the car has been powered down prior to this step, several runs must be made to the limits to allow the main CPU to record the limit velocity values.

From the 1005/1101 LCD interface, navigate to the "Elevator Setup" menu, "Set DT/UT Slowdown Clamp" and view the speed displayed for "Clamp Speed". Add 10 fpm to this "Clamp Speed" value and enter it into the "DT/UT Limit" value.

The number of slowdown limits depends on the speed of the car as show in the table 3-5.

Car Speed	Number of Slowdown Limits	Clamp Number	Limit Used
<= 250 fpm	1	2	UT, DT
300-500 fpm	2	3	UT1, DT1
600-700 fmp	3	4	UT2, DT2
800 + fpm	4	5	UT3, DT3

**Table 3-5: Slowdown Clamps**

Adjust speed clamps for each slowdown limits used as determined by the elevator’s contract speed.

**3.3.9.4 Verify Inspection Velocity Clamp on Safety Processor**

---

Place the car on inspection operation. From the 1005/1101 LCD interface, navigate to the "Adjustable Variables" menu, "Safety Proc Adj Vars" menu and then set the “Insp Velocity” parameter to 25 fpm.

Navigate to the "Car Motion" menu and set the “Inspect Speed” to 50 fpm. Run the car in either direction and verify that the car shuts down when the speed rises above 25 fpm.

Navigate to the "Safety Proc Adj Vars" menu and then set the "Insp Velocity" parameter to a speed clamp value of 140 fpm. Navigate to the "Car Motion" menu and set the "Inspect Speed" to the desired value.

### 3.3.10 Reduced Stroke Buffer ETS Limits Setup

---

When the buffer is not rated for contract speed, the operation for reduced stroke buffer is required. This operation utilizes an Emergency Terminal Speed Limiting Device (ETSLD). The Safety Processor and the Safety PAL provide this function with the use of the UTS, DTS and ETS Terminal Limits.

Both the Safety Processor and Safety PAL independently monitor the speed of the car and either can independently remove power from the driving machine and brake. This operation is enabled by having the Buffer Type in the controller configuration file set to 1 for Reduced Stroke Buffer, by the Safety Processor Adjustable Variable "Buffer Type" set to 1 for Reduced Stroke Buffer and the Reduced Stroke Buffer jumper being placed on the Main I/O board (directly above DNR, UP and FF chips in bottom right of the main board).

If any one of the settings for all three devices, the Main CPU, the Safety Processor and the Safety PAL, does not match, the car is not allowed to run. This is done to ensure that the job remains setup to match the configuration file.

The ETS limit consists of a sensor on the selector that is activated from a magnet at the top of the hoistway and one at the bottom. This input is used as a redundant check for the UTS and DTS limits. All limits are monitored by both the Safety Processor and Safety PAL.

The velocity set points used by the Safety Processor are the "ETS Up Vel" and "ETS Down Vel". Safety PAL velocity set points are the "PAL ETS Up Vel" and "PAL ETS Dn Vel". To ensure complete independence of ETSLD, the parameters used by the Safety PAL are stored in a non-volatile device accessible only to the Safety PAL.

To Change the PAL ETS velocity parameter, the ETSLD Test jumper must be placed on the Main I/O board and "ETS Setup Mode" adjustable variable on the Safety Processor must be set to 1 = AdjPALets.

If the PAL ETS parameters are changed without both of these settings, a new value can be entered but the existing value will not change.

 NOTE: The Safety PAL calculates the velocity in pulses per 30 milliseconds. To make it convenient for the user, the adjustable variable setting for PAL ETS up and down velocities are set in feet per minute.

Depending on the amount of error from the encoder resolution, the value returned once a new value is entered is the closest calculated value. For example, setting a velocity value of 470 fpm may return a value of 473 fpm. Because of the jumper requirements of the ETSLD operation, the ETS limit velocities for the Safety PAL can only be setup manually.

### 3.3.10.1 Manual Setup of ETS Limit Velocities

---

Before starting the setup procedure, temporarily install the ETSLD Test jumper on the Main I/O board. Navigate to the “Safety Proc Adj Vars” menu and set “ETS Setup Mode” to 1= AdjPALets. This will put the Safety PAL into Test/Setup mode which will also prevent the Safety PAL from detecting an ETS limit fault. While in this mode, the car cannot run in group operation or with the automatic doors enabled.

To set the speed clamps on the Safety PAL, make a one floor run to the top floor. After the car stops, view the “Elevator Status” display that shows the PAL velocity and status. Record the velocity at which the car actuated the ETS limit. It will be displayed as “ETUvel”. Run the car again to the top repeatedly from 2 floors down, then 3 floors down, etc., until top speed is reached. Record the limit velocities displayed each time the car stops at the top floor.

Make the same runs to the bottom floor starting from 1 floor, then 2 floors, then 3 floors, etc., until top speed is reached and record the velocity at which the car actuates the ETS limit (displayed as “ETDvel”). Do this each time the car stops at the bottom floor.

Take the highest speed value recorded in the runs to the top and bottom floors and add 10 fpm or 5% (whichever is larger) to use as the clamp speed values for the respective limits. Enter the clamp speed values for the “PAL ETS Up Vel” and “PAL ETS Dn Vel” from the “Safety Proc Adj Vars” menu.

Remove the ETSLD Test jumper from the Main I/O board. Navigate to the “Safety Proc Adj Vars” menu, and set “ETS Setup Mode”, to 0=Norm. Make several trips to the terminal landings from various floors to verify that a nuisance trip from the Safety PAL does not occur.

### 3.3.11 Verify Proper Operation of All Safety Circuits and Signal Devices

---



- Remove all temporary connections.
- Verify that all safety circuits and safety devices are installed and functioning properly.
- Verify that all car door electric contacts or car door interlocks are functioning properly.
- Verify that all hoistway door interlocks are functioning properly.
- Verify that all signal devices are functioning properly.

### 3.3.12 Perform Required Tests

---



Complete all required inspections and tests before placing the elevator in service.

<b>U8 Basics</b>		<b>Field Settings:</b>
Control Method	Closed Loop Vect	
<b>Drive A1 Submenu</b>		<b>Field Settings:</b>
Contract Car Spd	Nameplate Car Speed	
Contract Mtr Spd	Nameplate Motor RPM	
Encoder Pulses	Nameplate Rated Pulses	
NTSD Target Speed	10 FPM	
Mtr Torque Limit	250%	
Regen Torq Limit	250%	
<b>A2 Parameters Submenu</b>		<b>Field Settings:</b>
Accel Rate 0	7.99 ft/sec <sup>2</sup>	
Decel Rate 0	7.99 ft/sec <sup>2</sup>	
Jerk@Accel Start	30.00 ft/sec <sup>2</sup>	
Jerk@Accel End	30.00 ft/sec <sup>2</sup>	
Jerk@Decel Start	30.00 ft/sec <sup>2</sup>	
Jerk@Decel End	30.00 ft/sec <sup>2</sup>	
NTSD Decel Rate	10.00 ft/sec <sup>2</sup>	
NTSD DecJrkStart	12.00 ft/sec <sup>2</sup>	
NTSD DecelJrkEnd	12.00 ft/sec <sup>2</sup>	
<b>Motor Side Power Convert A4</b>		<b>Field Settings:</b>
Input Voltage	Line Voltage to Drive	
UV Detect Level	80%	80%
<b>Line Side Power Convert A5</b>		<b>Field Settings:</b>
Mtr Rated Power	Nameplate HP (IM)	
Mtr Rated Voltage	Nameplate Voltage (IM/PM)	
Max Frequency	Nameplate Frequency	
Motor Rated FLA	Nameplate Amps (IM)	
Number of Poles	Nameplate # of Poles	
Base Voltage	Nameplate Voltage (IM/PM)	
<b>User Switches C1 Submenu</b>		<b>Field Settings::</b>
Spd Command Src	Serial HPV Ref	Serial HPV Ref
Run Command Src	Serial HPV Seq	Serial HPV Seq
Serial Run Src	Terminal + Serial	Terminal + Serial
Serial Comm Mode	HPV Mode 1	HPV Mode 1
NTSD Mode	External - Input	External - Input
<b>Logic Inputs C2 Submenu</b>		<b>Field Settings:</b>
Term S1 Func. Sel.	Run Up	Run Up
Term S2 Func. Sel.	Run Down	Run Down
Term S3 Func. Sel.	Drive Enable	Drive Enable
Term S4 Func. Sel.	Motor Cont. Fdbk	Motor Cont. Fdbk
Term S5 Func. Sel.	Fault Reset	Fault Reset
Term S6 Func. Sel.	Not in NTSD	Not in NTSD
Term S7 Func. Sel.	Not Used	Not Used
Term S8 Func. Sel.	Not Used	Not Used
<b>Logic Outputs C3 Submenu</b>		<b>Field Settings:</b>
P1 Func Sel	During Run 2	During Run 2
M1-M2 Func Sel	Spd Reg Release	Spd Reg Release
M5-M6 Func Sel	Drive Ready	Drive Ready

**Table 3-6: Magnetek M1000 AC Geared Drive Settings**



<b>U8 Basics</b>		<b>Field Settings:</b>
Control Method	PM ClosedLoop Vct	
<b>Drive A1 Submenu</b>		<b>Field Settings:</b>
Contract Car Spd	Nameplate Car Speed	
Contract Mtr Spd	Nameplate Motor RPM	
Encoder Pulses	Nameplate Rated Pulses	
NTSD Target Speed	10 FPM	
Mtr Torque Limit	250%	
Regen Torq Limit	250%	
<b>A2 Parameters Submenu</b>		<b>Field Settings:</b>
Accel Rate 0	7.99 ft/sec <sup>2</sup>	
Decel Rate 0	7.99 ft/sec <sup>2</sup>	
Jerk@Accel Start	30.00 ft/sec <sup>2</sup>	
Jerk@Accel End	30.00 ft/sec <sup>2</sup>	
Jerk@Decel Start	30.00 ft/sec <sup>2</sup>	
Jerk@Decel End	30.00 ft/sec <sup>2</sup>	
NTSD Decel Rate	10.00 ft/sec <sup>2</sup>	
NTSD DecJrkStart	12.00 ft/sec <sup>2</sup>	
NTSD DecelJrkEnd	12.00 ft/sec <sup>2</sup>	
<b>Motor Side Power Convert A4</b>		<b>Field Settings:</b>
Input Voltage	Line Voltage to Drive	
UV Detect Level	80%	80%
<b>Line Side Power Convert A5</b>		<b>Field Settings:</b>
PM Mtr Power	Nameplate HP (PM)	
Mtr Rated Voltage	Nameplate Voltage (IM/PM)	
Max Frequency	Nameplate Frequency	
PM Mtr Rated FLA	Nameplate Amps (PM)	
PM Motor Poles	Nameplate # of Poles	
Base Voltage	Nameplate Voltage (IM/PM)	
<b>User Switches C1 Submenu</b>		<b>Field Settings::</b>
Spd Command Src	Serial HPV Ref	Serial HPV Ref
Run Command Src	Serial HPV Seq	Serial HPV Seq
Serial Run Src	Terminal + Serial	Terminal + Serial
Encoder Select	EnDat Sin/Cos	EnDat Sin/Cos
Serial Comm Mode	HPV Mode 1	HPV Mode 1
NTSD Mode	External - Input	External - Input
<b>Logic Inputs C2 Submenu</b>		<b>Field Settings:</b>
Term S1 Func. Sel.	Run Up	Run Up
Term S2 Func. Sel.	Run Down	Run Down
Term S3 Func. Sel.	Drive Enable	Drive Enable
Term S4 Func. Sel.	Motor Cont. Fdbk	Motor Cont. Fdbk
Term S5 Func. Sel.	Fault Reset	Fault Reset
Term S6 Func. Sel.	Not in NTSD	Not in NTSD
Term S7 Func. Sel.	Not Used	Not Used
Term S8 Func. Sel.	Not Used	Not Used
<b>Logic Outputs C3 Submenu</b>		<b>Field Settings:</b>
P1 Func Sel	During Run 2	During Run 2
M1-M2 Func Sel	Spd Reg Release	Spd Reg Release
M5-M6 Func Sel	Drive Ready	Drive Ready

**Table 3-7: Magnetek M1000 PMAC Gearless Drive Settings**

## Section 4 - Troubleshooting

---

### 4.1 General Information

---

The GALaxy controller is equipped with a number of features that aid in troubleshooting any problems that may occur. The physical layout of the controller provides ready access to all I/O terminals in order to make voltage measurements. All inputs have LEDs that monitor the state of the input. The controller is equipped with the 1005/1101 LCD Interface the Main CPU, the Safety Processor, and the NTS Processor. Section 05 describes the use of the 1005/1101 LCD Interface. In this section, the basic points of troubleshooting will be detailed.

### 4.2 Microprocessor CPU

---

With the power turned on, the “axy” in GALaxy on the 1005/1101 LCD Interface should be blinking at one second intervals, this indicates that the CPU is working correctly. If the “axy” is not blinking, then check voltage at the 5V terminal with respect to the 0V terminal, on the bottom edge of the 1100 CPU board. This voltage should read 5VDC. If not, then check the input (120VAC) and output voltage (5VDC) of the DC power supply. If the “axy” is not blinking and 5VDC is present at the 5V terminal with respect to the 0V terminal, then contact the factory. All job parameters that are field adjustable are stored in a non-volatile MRAM chip on the Main CPU board.

### 4.3 Input / Output Boards

---

The two main sections of all the I/O boards are the low voltage and the high voltage sections. The low voltage section consists of all the digital interfacing necessary for the CPU to communicate with the field components. The high voltage section consists of the field components (buttons, switches, lights, relays and sensors) and their associated input and output signals. The standard voltage for the Main I/O Board and the COP Board is 120VAC. However, the I/O expansion boards can accept a voltage range from 24 VAC, 24 VDC and 120 VAC. The rope gripper I/Os on the Main I/O Board can accept up to 240 VAC.

It is very important that the wiring schematics are reviewed in order to determine the voltages for which the controller was designed before applying power. Examples of possible problems that may exist on a controller could be a limit switch input not turning on, or an acknowledgement light not turning on. In both of these cases, the problem could be either on the high voltage section or the low voltage section of the circuit. The GALaxy control system is designed to enable the technician to check both the high voltage section and the low voltage section to correct the problem.

The high voltage section is checked with a digital voltmeter, or by individual LEDs that are associated with each input. Depending on the particular type of input or output, the voltage measured at the terminal will either be “high” or “low” with respect to its reference point. For example, to determine whether or not the Up Terminal Normal Limit Switch is conducting, the voltage should be measured at terminal **UN** with respect to **GND**. If the switch is conducting it should read 120VAC. If the switch is open, the voltage should read less than 50VAC. Another means by which to determine if the switch is conducting is to view the **UN** input LED. If the LED is on, the switch is conducting. If the LED is off, the switch is open.

The previous example determines whether or not the field component is functioning properly. However, to determine if the signal is actually being communicated to the CPU, the signal must be checked on the low voltage section of the board. The low voltage section is checked from the 1005/1101 LCD Interface. Using the previous example, from the 1005/1101 LCD interface, navigate to the **Inputs and**

**Outputs Menu, Car Inputs and Outputs** and Scroll through the I/O list until the **UN** input is located. The LCD will display  $UN = 1$ , if the **UN** switch is conducting, and or  $UN = 0$ , if the **UN** switch is open.

All the I/Os are optically isolated between the high voltage section and the low voltage section. The input optoisolators and the output solid-state relays are socketed ICs that are labeled on the silk screen of the various I/O boards with a **U** number (for example U45). If it is determined through the previous troubleshooting procedures that the input signal is present at the terminal, but is not being communicated to the CPU, the input optoisolator may be defective and can be replaced in the field. If it is determined that the CPU is communicating the output signal to the solid-state relay, but the voltage does not go high at the terminal, the solid-state relay may be defective and can be replaced in the field.



Any time IC chips are replaced, the power should be turned off and care should be taken in the removal of the old chip and replacement of the new one. Please pay attention to the chip orientation. All of the I/Os and their associated ICs are listed in the controller wiring schematics.

#### 4.4 Run Sequence

---

The following diagram in Figure 4.0 shows the run sequence of the controller. The timing of BRK changes with the adjustment variable DON Start Control. When set to 0, the BRK output turns on before DON and when set to 1 BRK turns on after DON. The BRK timing typical works best with this adjustable variable set to 1.

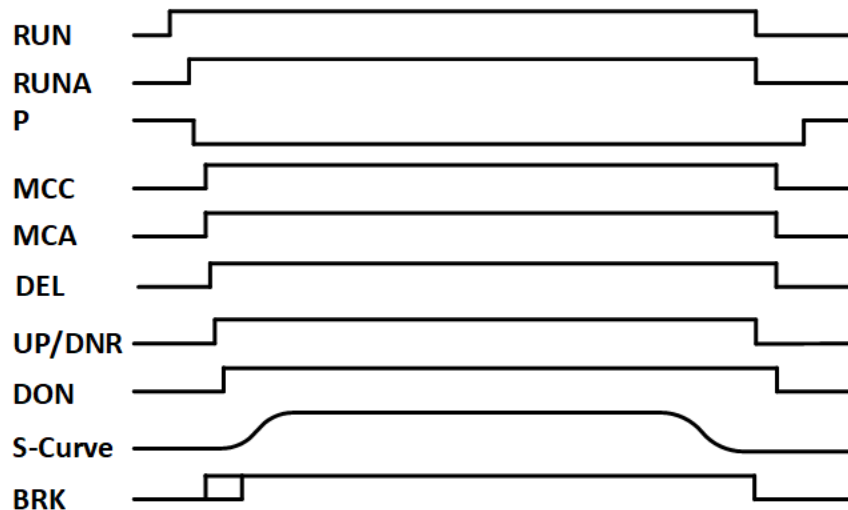

Figure 4-1: Run Sequence: GALaxy IV Controller

#### 4.5 The Safety Processor and Safety PAL

---

The Safety Processor and Safety PAL monitor controller run outputs, inputs, and velocity feedback. Their function is to interrupt or prevent the elevator car from running, in case of unsafe conditions.

The Safety Processor monitors the speed of the car and prevents over speeding and unintended motion, as well as, monitoring the leveling speed.

The Safety Processor stops or prevents a run by dropping the SFC control relay, which, in turn, will open the safety string.

The Safety PAL stops or prevents a run by dropping RUNA, BRK, UP, DNR, UF and DF outputs.

#### 4.5.1 The CPU outputs that are controlled by the Safety PAL

---

##### **Run Control - CPU Control Outputs:**

UP – Up Command  
 DNR – Down Command  
 UF – Up Fast Command  
 DF – Down Fast Command  
 RUNA – Run Control  
 BRK – Brake Control

#### 4.5.2 The inputs monitored by the Safety Processor and Safety PAL

---

##### **Door Status:**

DLT – Door Lock Top  
 DLM – Door Lock Middle  
 DLB – Door Lock Bottom  
 GBP – Gate Bypass  
 LBP – Lock Bypass

##### **Door Zone Status:**

UL – Up Limit  
 DZ – Door Zone  
 DL – Down Limit

##### **Inspection Status & Control:**

Auto – Automatic Operation	INS – Car Top Inspection
ICI – In Car Inspection	IU – Car Top Inspection Up
ACC – Access	ID – Car Top Inspection Down
TAU – Top Access Up	MRI – Motor Room Inspection
TAD – Top Access Down	MRIU – Motor Room Inspection UP
BAU – Bottom Access Up	MRID – Motor Room Inspection Down
BAD – Bottom Access Down	

##### **Terminal Limit Status:**

ETS – Emergency Terminal Slowdown Verification Input for both Up and Down  
 UTS – Up Emergency Slowdown  
 DTS – Down Emergency Slowdown

#### 4.5.3 Outputs controlled by the Safety Processor

---

GR1 – GR1 Relay (Drops the Gripper)  
 SFC – SFC Relay Control

Figure 4-2 shows a block diagram of the Safety Processor and Safety PAL.

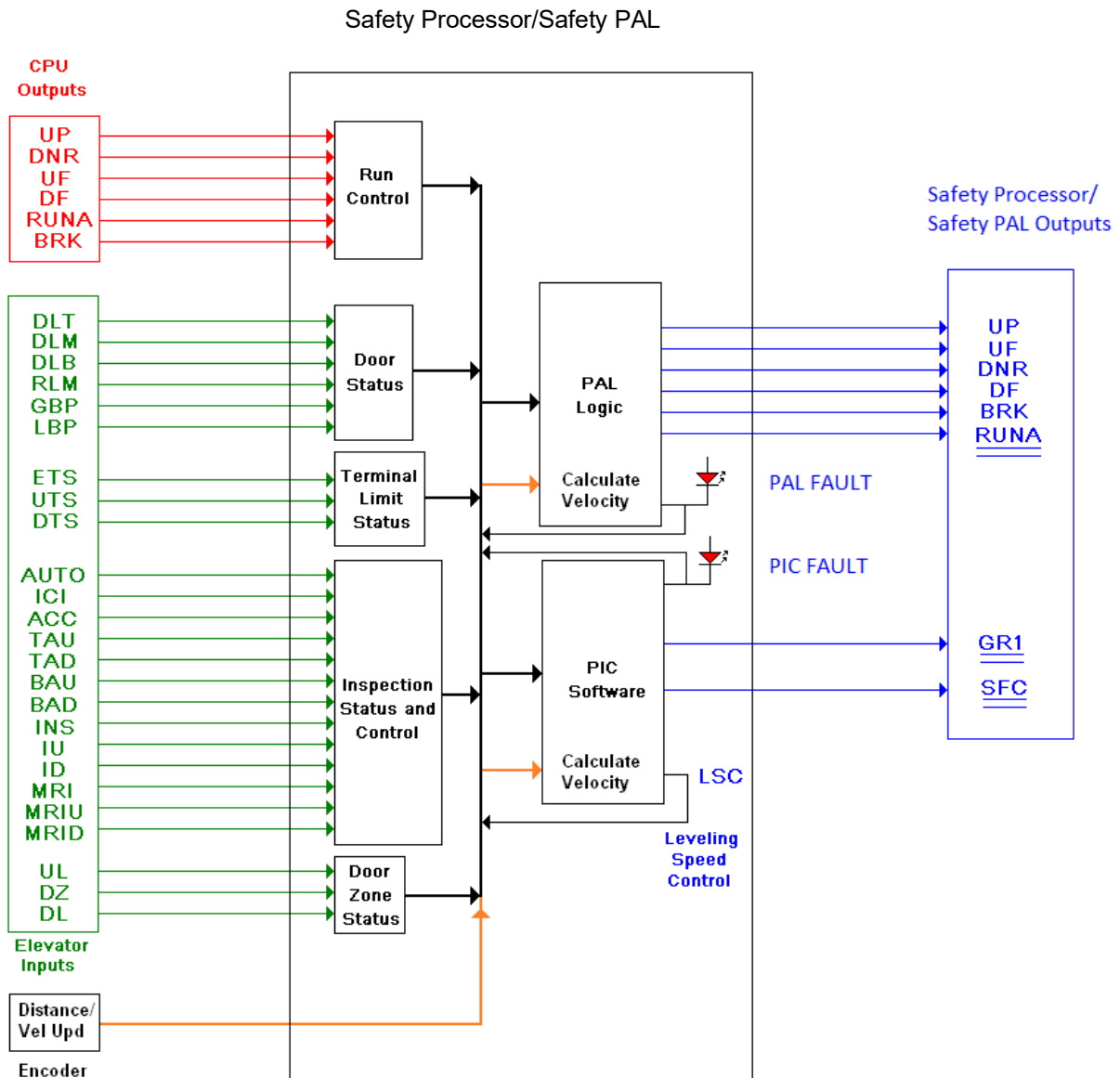

Figure 4-2: GALaxy IV Safety Processor and Safety PAL Block Diagram

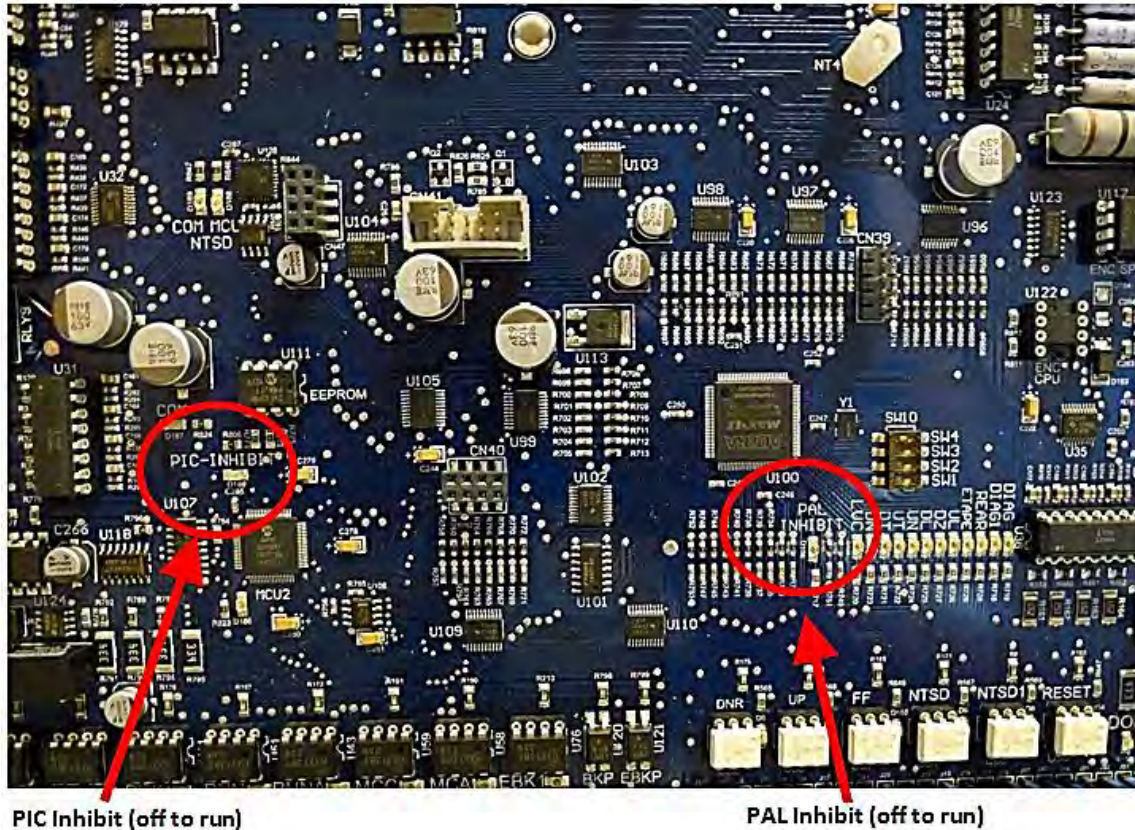

Figure 4-3: The 1102 Main I/O Board

#### 4.5.4 PIC and PAL Inhibit LEDs

The Safety Processor and Safety PAL have two fault LEDs, one on the bottom left of the board for the PIC inhibit and one on the bottom right of the board for the PAL inhibit. See Figure 4-3.

**i Important:** When either the PIC or PAL LED is on, the car is prevented from running.

The Safety Processor and Safety PAL perform the following functions:

- Verify the speed of the car when the emergency terminal limits are activated
- Verify that the doors are closed and safe to run
- Verify all inspection operations
- Verify that the car velocity is not greater than 150 fpm in the door zone and with the doors open.

While the Safety Processor and Safety PAL cannot turn on any run control signals, it can turn off the following signals from the main CPU: RUNA, BRK, UP, and DNR. The SFC relay in the safety string is also controlled by the Safety Processor.

The Safety Processor detects two types of faults: active faults and velocity faults. Active faults are input conditions that are considered as unsafe or an error such as the Lock Bypass Switch set to “Bypass” while

the car is on automatic. Velocity faults are generated when the Safety Processor detects that the car speed is too high during certain conditions, such as actuating the DTS terminal limit at a speed greater than the speed setting for that limit. Both types of faults are reset after a 2 second delay when the condition is corrected, and the main CPU is not commanding an up or down run.

#### 4.5.5 MCU and COM LEDs

---

The Safety Processor has two LEDs, MCU and COM, for CPU and CAN Bus communication status. The MCU LED will blink at a one second interval to show that the Safety Processor is running. The COM LED blinks at a one second interval when it has communication with both the selector and NTS Processor. If communication is lost with one of the two devices, the LED will blink at an irregular interval. If there is no communication with either device, the LED will turn off.

#### 4.5.6 Troubleshooting Safety Processor and Safety PAL Faults

---

When troubleshooting errors detected by the Safety Processor or Safety PAL, take the following steps:

- Check LED status. If either PAL inhibit or PIC inhibit LED is on, it indicates an error.
- View the elevator Safety Processor status under the **Elevator Status** Menu on the 1005/1101 LCD Interface. Any status other than Automatic Mode or a valid inspection service is an error.
- Check the MCU and COM LED status. Both LEDs should be blinking at one second intervals, as mentioned above.
- From the 1005/1101 LCD Interface, navigate to the **SPB Inputs and Outputs** Menu, and view all of the I/O status. See section 4.7 for a complete description of the input and output signals.
- From the 1005/1101 LCD Interface, navigate to the **Faults Log** Menu, and view the recorded faults. When a fault occurs on the Safety Processor, it will transmit the fault code to the Main CPU, and the fault will be recorded in the main CPU fault log.

### 4.6 Fault Log

---

Faults that are detected by the Main CPU can be viewed on the 1005/1101 LCD Interface by navigating to **Reset / View Faults Log** Menu, => **View Fault Log**. The lists of possible faults detected by the Main CPU, the Safety Processor, and the NTS Processor are listed in section 6.1, System Faults. By pressing the *ENTER* button on the 1005/1101 LCD Interface when the particular fault is being displayed, the interface will display detailed information for that fault. Section 6.2, Detailed Faults, describes this information.

In general, when a fault occurs, the system records the state of all the items listed in section 6.2 and stores the data in two different buffers, the normal and long-term fault buffers. The normal fault buffers can hold the last 50 faults that occurred, and the long-term fault buffer holds the last 600 faults that occurred. The data in the normal fault buffer is accessed from the **Fault Log** Menu. The long-term fault buffer can be copied to the SD Card, and viewed on a PC using a text editor such as Note Pad.

In both cases the highest numbered fault is the newest fault.

## 4.7 Main CPU Inputs and Outputs

<b>Table 4-1: Main CPU Inputs &amp; Outputs</b>	
<b>Name</b>	<b>Description</b>
1CA-nCA	1st → Nth Floor Car Call Acknowledge Outputs
1CAR-nCAR	1st → Nth Floor Rear Car Call Acknowledge Outputs
1C-nC	1st → Nth Floor Car Call Inputs
1CR-nCR	1st → Nth Floor Rear Car Call Inputs
1U-(n-1)U	1st → (Nth-1) Floor Up Hall Call Inputs
1UA-(n-1)UA	1st → (Nth-1) Floor Up Hall Call Acknowledge Outputs
1UAR-(n-1)UAR	1st → (Nth-1) Floor Rear Up Hall Call Acknowledge Outputs
1UR-(n-1)UR	1st → (Nth-1) Floor Rear Up Hall Call Inputs
2DA-nDA	2nd → Nth Floor Down Hall Call Acknowledge Outputs
2DAR-nDAR	2nd → Nth Floor Rear Down Hall Call Acknowledge Outputs
2D-nD	2nd → Nth Floor Down Hall Call Inputs
2DR-nDR	2nd → Nth Floor Rear Down Hall Call Inputs
ACC	Access Operation Input
AD	Automatic Door Switch Input
ALT	Alternate Fire Smoke Detector Sensor Input
ATT	Attendant Operation Input
ATTDN	Attendant Down Input
ATTUP	Attendant Up Input
AUTO	Automatic Operation Input
B16	Binary Position Sensor 16 Input
B32	Binary Position Sensor 32 Input
BAD	Bottom Access Down Input



**Table 4-1: Main CPU Inputs & Outputs**

Name	Description
BAU	Bottom Access Up Input
BF	Bottom Final Input
BKS	Brake Switch Input
BP	Fire Phase I Smoke Detector Bypass Input
BP1	Binary Position Sensor 1 Input
BP2	Binary Position Sensor 2 Input
BP4	Binary Position Sensor 4 Input
BP8	Binary Position Sensor 8 Input
BRK	Brake Pilot Output
BRKi	Brake Control Input
BUZ	Machine Room Buzzer Output
CDL	Cab Down Lantern Output
COL	Counter Weight Collision Switch Input (Traction Elevators)
CS	In Car Stop Switch Input
CSS	Car Safety String Input
CTA	Car Top Automatic Input
CTS	Car Top Stop Switch Input
CUL	Cab Up Lantern Output
DBC	Dynamic Brake Relay Control Output
DC	Door Close Output
DCB	Door Close Button Input
DCBR	Door Close Button Rear Input
DCC	DAC Clear Output

**Table 4-1: Main CPU Inputs & Outputs**

<b>Name</b>	<b>Description</b>
DCL	Door Close Limit Input
DCLR	Door Close Limit Rear Input
DCR	Door Close Rear Output
DDA	Down Direction Arrow Output
DFi	Down Fast Input
DL	Down Level Sensor Input
DL-1	Down Level Sensor Secondary Input
DLB	Door Lock Bottom Input.
DLB-1	Door Lock Bottom Secondary Input
DLM	Door Lock Middle Input
DLM-1	Door Lock Middle Secondary Input
DLT	Door Lock Top Input
DLT-1	Door Lock Top Secondary Input
DN	Down Normal Limit Input
DNi	Down Run Input
DNR	Down Pilot Output
DO	Door Open Output
DOB	Door Open Button Input
DOBR	Door Open Button Rear Input
DOL	Door Open Limit Input
DOLR	Door Open Limit Rear Input
DON	Drive On
DOR	Door Open Rear Output

**Table 4-1: Main CPU Inputs & Outputs**

Name	Description
DPM	Door Protect Monitor Input
DT	Down Terminal Limit Input
DT1-6	Down Terminal Input 1-6
DTS	Down Emergency Terminal Slowdown Input
DZ	Door Zone Input
DZsn	Door Zone Sensor Input
EBK	Emergency Brake Relay Output
EBK1	Emergency Brake 1 Secondary Relay Output
EBK1i	Emergency Brake 1 Secondary Relay Input
EBKi	Emergency Brake Relay Input
EE	Electric Eye Input
EER	Electric Eye Rear Input
EMP	Emergency Power Input
EPS	Emergency Power Select Input
EQ	Earthquake Sensor Input
ETS	Emergency Terminal Up and Down Secondary Input
FB	Fire Buzzer Output
FF	Full Field Pilot Output
FFS	Fire Fighters Stop Switch Input
FL	Fire Phase I Light Output
FS	Fire Phase I On Hall Switch Input
FS2	Fire Switch Phase II On Input
FS2C	Fire Switch Phase II Call Cancel Input

**Table 4-1: Main CPU Inputs & Outputs**

<b>Name</b>	<b>Description</b>
FS2H	Fire Switch Phase II Hold Input
FST	Fire Stop Switch Override Output
FSTP	Fire Stop Switch Override Output
FSTPI	Fire Stop Switch Override Input
GBP	Gate Switch Bypass Input.
GOV	Governor Switch Input
GR1R	Rope Gripper 1 Relay Output.
GR2R	Rope Gripper 2 Relay Output.
GRT1	Rope Gripper Test Input 1
GRT2	Rope Gripper Test Input 2
GS	Car Gate Switch Input
GS-1	Gate Switch Secondary Input
GTS	Rope Gripper Trip Switch Input
HB	Handicap Buzzer Output
HBE	Handicap Buzzer Enable Input
HSS	Hatch Safety String Input
HWS	Hoistway Smoke Sensor Input
HWS2	Hoistway Smoke Sensor 2 Input
ICI	In-Car Inspection Input
ICR	Inconspicuous Riser Input
ID	Car top Inspection Down Input
IEN	Inspection Enable Input
IND	Independent Input

**Table 4-1: Main CPU Inputs & Outputs**

Name	Description
INDC	Independent Input in COP
INS	Car Top Inspection Input
ISER	In Service Output
IU	Car Top Inspection Down Input
LBP	Lock Bypass Input
LD	Down Hall Lantern Output
LDR	Rear Down Hall Lantern Output
LE	Level Enable Output
LE1	Level Enable 1 Output.
LE2	Level Enable 2 Output
LU	Up Hall Lantern Output
LUR	Rear Up Hall Lantern Output
LWA	Load Weighing Anti-nuisance
LWB	Load Weighing Bypass Input
LWD	Load Weighing Dispatch
MCA	Motor Contactor Output
MCAI	Motor Contactor Input.
MCC	Motor Contactor Output
MCCi	Motor Contactor Input.
MCX	Motor Contactor Auxiliary Input in series with the SFC terminal
MES	Main Egress Smoke Detector Sensor Input
MRI	Motor Room Inspection Input
MRID	Motor Room Inspection Down Input

**Table 4-1: Main CPU Inputs & Outputs**

<b>Name</b>	<b>Description</b>
MRIE	Motor Room Inspection Enable Input
MRIU	Motor Room Inspection Up Input
MRS	Motor Room Smoke Sensor Input
MRSW	Motor Room Stop Switch
NBFB	Nudging/Fire Buzzer Output
NTSD	Normal Terminal SlowDown Initiation Output
NTSD1	Normal Terminal SlowDown 1 Secondary Initiation Output
NTSDi	Normal Terminal SlowDown Initiation Input
NUD	Door Nudging Output
NUDR	Door Nudging Rear Output
OVL	Overload Input
P	Potential (Run Contactor) Input
P1-Pn	1ST – Nth Discrete Floor Position Indicator Outputs
PFC	Primary Fault Control Output
PFCi	Primary Fault Control Input
PS	Pit Switch Input
RDY	Drive Ready Input
RGS	Rear Car Gate Switch Input
RGS-1	Rear Car Gate Switch Secondary Input
RLM	Rear Lock Middle Input
RLM-1	Rear Lock Middle Secondary Input
RLS	Rail Lock Switch Input
RST	Reset Drive Output

**Table 4-1: Main CPU Inputs & Outputs**

Name	Description
RTL	Return to lobby Input
RUN	Run Pilot Output
RUNAi	Run Auxiliary Input
RUNi	Run Input.
RUNX	Run Auxiliary Relay Input (Hardware run signal to the drive)
S10	Controller Power Input
SE	Safety Edge Input
SER	Safety Edge Rear Input
SFCi	Secondary Fault Control Input
TAD	Top Access Down Input
TAU	Top Access Up Input
TF	Top Final Input
TPL	Temp Low Input (Hydraulic Elevators)
UDA	Up Direction Arrow Output
UFi	Up Fast Input
UL	Up Level Sensor Input
UL-1	Up Level Sensor Secondary Input
UN	Up Normal Limit Input
UP	Up Pilot Output
Upi	Up Run Input
UT	Up Terminal Limit Input
UT1-6	Up Terminal Input 1-6
UTS	Up Emergency Terminal Slowdown Input

## 4.8 Safety Processor Inputs and Outputs

<b>Table 4-2: Safety Processor Inputs &amp; Outputs</b>	
<b>Name</b>	<b>Description</b>
ACC	Access. Input equals 1 when the car is on access operation.
AUTO	Auto Input. Input equals 1 when the car is on automatic operation.
CTI	Car Top Inspection. Input equals 1 when the car is on car top inspection.
DL-1	Down Level Secondary Input. Input from the selector that the car is on the down level sensor in the door zone.
DLB-1	Door Lock Bottom Secondary Input. Input equals 1 when the bottom door lock is made.
DLM-1	Door Lock Middle Secondary Input. Input equals 1 when the middle door locks are made.
DLT-1	Door Lock Top Secondary Input. Input equals 1 when the top door lock is made.
DNR	Down Run Output. Output from the main CPU when the car is running down.
DT	Down Terminal Slowdown. Input goes low when the car is on the down terminal slowdown limit.
DTS	Down Emergency Terminal Slowdown. Input goes low when the car is on the down emergency terminal slowdown limit.
GBP	Gate Bypass. This is the input from the gate bypass switch. 1 = bypass switch is on.
GS-1	Gate Switch Secondary Input. Input equals 1 when the front door gate switch is made.
ICI	In Car Inspection. Input equals 1 when the car is on in-car inspection operation.
LBP	Lock Bypass. This is the input from the lock bypass switch. 1 = bypass switch is on.
LSCS	Leveling Speed Control. Output comes on when the car is traveling less than 150 fpm.
MRI	Motor Room Inspection. Input equals 1 when the car is on motor room inspection.
RGS	Rear Gate Switch. Input equals 1 when the rear door gate switch is made.
RLM-1	Rear Lock Middle Input. Input equals 1 when the rear middle locks are made.
SFCO	Safety Fault Control Output. Output must be on to energize the SFC relay. When this relay is dropped out, the safety string will be opened.



<b>Table 4-2: Safety Processor Inputs &amp; Outputs</b>	
<b>Name</b>	<b>Description</b>
UL-1	Up Level Secondary Input. Input from the selector that the car is on the up level sensor in the door zone.
UP	Up Run Output. Output from the main CPU when the car is running up.
UT	Up Terminal Slowdown. Input goes low when the car is on the up terminal slowdown limit.
UTS	Up Emergency Terminal Slowdown. Input goes low when the car is on the up emergency terminal slowdown limit.

#### 4.9 NTS Processor Inputs and Outputs

<b>Table 4-3: NTS Processor Inputs &amp; Outputs</b>	
<b>Name</b>	<b>Description</b>
DN	Down Normal Slowdown Input
DNR	Down Run Input
DT	Down Normal Terminal Slowdown Input
DT1-6	Down Normal Terminal Slowdown 1 - 6 Inputs
NTSD	Normal Terminal Slowdown Initiation Output
NTSD1	Normal Terminal Slowdown 1 Secondary Initiation Output
UN	Up Normal Slowdown Input
UP	Up Run Input
UT	Up Normal Terminal Slowdown Input
UT1-6	Up Normal Terminal Slowdown 1 - 6 Inputs

## 4.11 APS Selector Inputs and Outputs

<b>Table 4-4: APS Selector Inputs &amp; Outputs</b>	
<b>Name</b>	<b>Description</b>
UL	P2 Up Level Input
DL	P2 Down Level Input
DZ	P2 Door Zone Input (DZU ANDed with DZD for a 2 inch door zone)
DZA	P2 Door Zone Auxiliary Input (DZU ORed with DZD for a 3 inch door zone)
DZU	P2 Door Zone Up Input (Turns on 2" below the floor until 2" above the floor)
DZD	P2 Door Zone Down Input (Turns on 2" above the floor until 2" below the floor)
DZ Clip	P2 Door Zone Clip Input (Turns on momentarily when the camera passes the clip)
UN	P2 Up Normal Stop Input (2" above the top floor)
DN	P2 Down Normal Stop Input (2" below the bottom floor)
DT	P2 Down Normal Terminal Slowdown Input
DT1-DT3	P2 Down Normal Terminal Slowdown 1-3 Inputs
UT	P2 Up Normal Terminal Slowdown Input
UT1-3	P2 Up Normal Terminal Slowdown 1 – 3 Inputs
*DZ	P1 Door Zone Input (2" door zone)
*DZA	P1 Door Zone Auxiliary Input (3" door zone)
*DZ Clip	P1 Door Zone Clip Input (Turns on momentarily when the camera passes the clip)
*UN	P1 Up Normal Stop Input (2" above the top floor)
*DN	P1 Down Normal Stop Input (2" below the bottom floor)



Inputs with an asterisk in front of the mnemonic are for Processor 1 on the selector interface board. All other inputs are for Processor 2 on the selector interface board. Processor 1 operates from the same camera channel as the Main CPU (channel A). Processor 2 operates from camera channel B.

## 4.12 Relocate I/Os

Special Relocation I/O's are located on the Machine Room CAN bus, the Car Top CAN bus and the Group CAN bus. Each CAN bus has three inputs and three outputs for this purpose, and are named as follows:

MRCAN		CTCAN		GRCAN	
Inputs	Outputs	Inputs	Outputs	Inputs	Outputs
MSPI1	MSPO1	CSPI1	CSPO1	GSPI1	GSPO1
MSPI1	MSPO2	CSPI2	CSPO2	GSPI2	GSPO2
MSPI3	MDPO3	CSPI3	CSPO3	GSPI3	GSPO3

Mnemonic legend:

**M (MRCAN) SP (Spare) I (Input) 1**

**C (CTCAN) SP (Spare) O (Output) 1**

**G (GRCAN) SP (Spare) I (Input) 3**

The locations of these I/Os are preset in the io.dat file and can be viewed on the diagnostic I/O display or on the board electronic ink label.

To relocate the I/O, select the "Relocate I/O" menu from the "Inputs and Outputs" menu. Then select the "Add I/O Relocation". Use the Up or Down button to select the input type and location such as CSPI1, (CTCAN car spare input 1). The type is an input and CSPI1 is located where the desired Input will be relocated. Hit the Enter button and then the Up or Down to select the I/O to be relocated. Only I/O's allowed on the selected bus will be displayed. When you reach the I/O to be relocated, then hit the Enter button again. Once an I/O has been selected, power must be cycled on the controller for the relocation to take place.

To remove an individual I/O from the relocation table, select the "Remove I/O Relocation" menu and then "Select I/O: None" and hit enter. To remove all I/O relocations, select the "Clear Relocation Table" menu and hit enter. Please refer to the Inputs and Outputs menu of the LCD Interface section for a graphic view of the Relocate I/Os menu.

## 4.13 GALileo Enhanced Diagnostics

The GALaxy IV controller is equipped with the GALileo Enhanced Diagnostics feature that provides elevator personnel with diagnostic information on a machine room monitor or smart device. The GALileo Enhanced Diagnostics includes the following features.

- Group Screen
- Fault Log
- Car I/O Screen
- Hall I/O Screen
- Adjustable Variables
- Trace Screen
- Traffic Analysis
- Event Scheduling
- Service Settings
- Call Lockouts
- Fault Description List
- PDF copies of Project Documents
- Instructional Videos

The GALileo User's Guide provides a complete description of the GALileo features.

### 4.13.1 GALileo Trace Screen

---

The “Trace Screen” feature allows elevator personnel to record the operation of the elevator over a period of time and replay this recorded information. This recorded event, provides detailed information to assist in adjustment and troubleshooting.

This feature requires v7.01.07 software or later and can be accessed from the machine room monitor or smart device.

The “Trace Screen” functions as follows:

When the controller powers up, it begins storing trace information at the preset time interval, usually 10 msec, but can be adjusted to 20, 30 or 40 msec. This means that data is recorded for 5 seconds duration and will continue to cycle until stopped by the F2 key or from a set trigger.

The trace stops storing data when a trigger condition occurs. The trace information is the same data that is stored for each fault occurrence but is stored in volatile memory, i.e. ***the data is lost when power is cycled.*** Even though the trace data is not stored in non-volatile memory, the trigger setup conditions is stored in non-volatile memory and will not be lost when power is cycled.

The playback commands from the machine room monitor are:

- F1 to re-start the trace
- F2 to trigger a stop trace condition. When the trigger is activated the controller will store 35 more trace frames and then will stop.
- The Home key places the count (frame) to the trigger point after the trace is stopped – start of trigger.
- The End key places the count to the last frame after the trace has stopped (i.e. 35 frames after the trigger point) – end of trigger.
- If you press the End key and then one Up arrow key, the frame will be at the start of the trace.
- The Up and Down arrows increment or decrement the frame by one count
- The Page Up and Page Down keys increment or decrement the frame by ten counts.
- The Right and Left arrow keys scroll part of the status screen data at the bottom of the screen.

Using the GALileo interface, the playback commands are graphical, and allow you to step through the trace one frame at a time, 10 frames at a time, or move the slider to any position. To play the trace for the entire run use the play button.

The trace trigger and timing can be setup from the “Trace Setup” menu under “Software Utilities”. Below is a list of the trace setup menus and their functions:

- Stop Trace Recording
- Start Trace Recording
- Trace Time Interval – Time interval from 10 to 20, 30 or 40 msec. Extends the trace time from 5 seconds to 10, 15 or 20 seconds respectively.
- Trace Trigger Arm – Arm the trace for a condition after power up:
  - Always Armed
  - Power Up Reset
  - Initial At Floor
  - Motion Start
  - Initial Stop,
  - Re-level Start
  - Front Door Open Start
  - Front Door Dwell Start
  - Front Door Close Start
  - Rear Door Open Start
  - Rear Door Close Start
  - Rear Door Close Start
  - Inspection Start
  - Safety String Start
- Trace Trigger Window – Time window for logic events to be considered valid. When the trigger condition is set for more than one condition and a trigger condition occurs

momentarily, this is the duration of time that the momentary condition is considered valid. A value of 35 is recommended.

- Setup Trace Trigger – The logic condition for the trace trigger to occur. There is an “AND” trigger variable and an “OR” trigger variable. When a trigger condition is selected, the user must set it in the “AND” or “OR” trigger variable. A trigger condition cannot be set in both trigger variables. The trigger occurs when all the “AND” conditions are met or any of the “OR” conditions are met. In addition, the trigger ARM must also be active. Trigger conditions can be set from the following:
  - Fault change
  - Fault match
  - servf change
  - servf match
  - procf change
  - procf match
  - run\_statusf change
  - run\_statusf match
  - slowdown change
  - slowdown match
  - rear slowdown change
  - rear slowdown match
  - statusf change
  - statusf match
  - statusf2 change
  - statusf2 match
  - Fault Bits 0 change
  - Fault Bits 0 match
  - Fault Bits 1 change
  - Fault Bits 1 match
  - Fault Bits 2 change
  - Fault Bits 2 match
  - Fault Bits 3 change
  - Fault Bits 3 match
  - SPB service change
  - SPB status change
  - SPB command change
  - NTS service change
  - NTS status change
  - NTS command change
- Show Trace Trigger Logic
- Clear Trace Trigger Logic

## Section 5 – LCD Interface

### 5.1 Operating the LCD Interface

#### 5.1.1 Interface Operator Panel



**UP Button** is used to scroll up to the next menu item, or increment data values.



**DOWN Button** is used to scroll down to the next menu item, or decrement data values.



**MODE Button** is used to go back to the previous menu, or select digits of data values.



**ENTER Button** is used to select menu items, or complete the operation of changing data values.



**Potentiometer** is used to adjust the viewing angle. It makes the display lighter or darker.

The LCD Interface Board uses a 2 line by 24-character display, and it includes four buttons for navigation and menu item selections (see above). This interface allows the user to adjust parameters, view critical controller information, implement controller setup options, and view elevator status information. Upon power-up, the interface board shows a blinking “GALaxy” on the display to indicate the controller is running, as shown in the photograph above.

The four buttons used for operating the LCD display are UP, DOWN, MODE, and ENTER. The UP and DOWN buttons are used to scroll up and down items listed for selection in the controller menus. The ENTER button is used to select a particular item. Some menu items, have submenus containing additional selection items. Again, in these submenus, the UP and DOWN buttons are used for scrolling through the items, and the ENTER button to is pressed to make selections.

The MODE button is used to return to previous menus.

When a menu item is an adjustable variable, the item is selected with the ENTER button, and the UP or DOWN buttons are used to adjust the item's value. In number entries, the MODE button is used to move the cursor to the next digit. Once the appropriate value has been selected, the ENTER button is used to confirm/complete the variable change operation, and exit edit mode.

The following pages in this section provide descriptions of the flowcharts at the end of the chapter. The descriptions and flowcharts are shown separately, to allow more space for the graphics, for better readability.

For clarity and better organization, the descriptions are provided in the same order as the flowcharts.

5.1.2 LCD Interface Main Menu

The flowchart for the Main Menu shows the top-level menus in the controller system.

5.1.3 Elevator Status

The **Elevator Status** Display continuously updates to show the current status and fault information regarding the elevator. The UP and DOWN keys allow access to both the status display and the velocity display. When a system fault occurs, it will be shown on the top line of the status display while the fault exists, and it will remain displayed for 60 seconds after the fault is cleared. The following six categories of status information (including fault information) may appear on this screen:

<b>Elevator Service:</b>		
Out of Service Automatic Service Independent Service Load Weighing By Pass Attendant Service Code Blue Service Fire Service Phase 2 Emergency Power Service Earth Quake Service Fire Phase 1 Main Return	Fire Phase 1 Alt Return Homing Reset Going Up Reset Going Down Stalled Out of Service Return to Lobby Load Weighing Overload Medical Emergency Serv. Calibrate Load Weigher Car Switch Elevator Off	Hall Switch Elevator Off Low Pressure Hospital Service Priority Service Security Recall Sabbath Service TUG Service Hot Oil Operation Riot Control
<b>Elevator Status:</b>		
Reset Mode Inspection Mode Up Fast Up Transition Leveling Up Down Fast Down Transition Leveling Down Soft Start Mode	Constant Accel Roll Over Max Vel Constant Velocity Roll Over Deccel Constant Deccel Targeting Floor Emergency Slowdown Safety String Open Elevator Off Line	Elevator Parked Waiting Assignment Door Procedure Elevator Stalled Reset Hydro Jack Low Pressure Mode Auto Learn HW Mode Emp Recovery Mode Hot Oil Mode
<b>Door Status:</b>		
Elev Door Closed Elev Door Opening Elev Door Dwelling Elev Door Open Elev Door Closing Elev Door Nudging F1RET Door Open F2CPO Door Open	F2CPO Door Opening F2CPO Door Closed F2CPO Door Closing F2CPC Door Open F2CPC Door Opening F2CPC Door Closed F2CPC Door Closing F2HLD Door Open	F2HLD Door Opening F2HLD Door Closed F2HLD Door Closing F2MBC Door Open F2MBC Door Opening F2MBC Door Closed F2MBC Door Closing
<b>Rear Door Status:</b>		
Rear Door Closed Rear Door Opening Rear Door Dwelling Rear Door Open Rear Door Closing Rear Door Nudging F1RET RDor Open F2CPO RDor Open	F2CPO RDor Opening F2CPO RDor Closed F2CPO RDor Closing F2CPC RDor Open F2CPC RDor Opening F2CPC RDor Closed F2CPC RDor Closing F2HLD RDor Open	F2HLD RDor Opening F2HLD RDor Closed F2HLD RDor Closing F2MBC RDor Open F2MBC RDor Opening F2MBC RDor Closed F2MBC RDor Closing

High Priority Elevator Status:		
S10 Input Off	Run Fault: Shutdown	KEB Drv Not In Run
HC Input Off	Annual Safety Test	At Floor Shutdown
SS Input Off	Waiting for SAFE	1036 Auto Run Hold
READY Input Off	Terminal Limit Flt	Reset Run Failure
Gripper/EBK Fault	GTS Input Off	Invalid SEL count
I/O Error	UL, DL, DZ Off at FL	COP can comm error
Insp or Byp Error	Brake CAN Error	Encoder can comm error
Bin. Pos. Error	Fire Stop Sw. Off	IO Test in progress
Position Error	SEL CAN Com Error	Gripper Test in progress
AD Input Off	UL or DL Fault	No Power to Drive
CS Input Off	Leveling Fault	Non Interference timer
Door Zone Fault	Hardware Init Flt	Door open request
Gate/Lock Fault	Front Door Cls Flt	Waiting for DPM
P Input On	Rear Door Clos Flt	Waiting for RPM
Looking for DCL	Line Voltage Fault	Viscosity operation
Door Close Contact	Door Voltage Fault	Leveling request
Brake Switch Fault	BK Lift Sw Run Flt	Terminal Limit Speed Clamp
TOC CAN Com Error	Door Motor OVL	Sped Rate Clamp
DRIVE Com Error	Learn Hoistway Flt	Front EE Test failed fault
Saf Proc Com Error	UPS Fault	Rear EE Test failed fault
DB Res. Temp. Trip	Em Brake CAN Error	Setup Mode No Auto
<b>Fault Status:</b>		
See the CPU FAULTS Section		

### 5.1.4 Set Calls and Lockouts

When a car is in a group, the menu system allows access to options for setting both hall calls and car calls. When the controller is not the group, only car calls can be set. Rear car calls and lockouts are displayed only when the car has a rear door.

### 5.1.5 Car Call Test

This menu allows elevator personnel to initiate a continuous test of the elevator. The test can be conducted with the AUTO DOORS switch set to ON or OFF. The **Car Call Test** can be initiated or discontinued by following the instructions in the menu. When performing the **Car Call Test**, the car will answer all registered calls in one direction. When the last call has been answered for this direction, the calls will be automatically re-initiated and the car will begin to answer calls in the opposite direction. This operation will continue until one of the following situations occurs.

- The test is discontinued from the LCD interface.
- The car is taken out of automatic operation.
- A fault occurs in the system.



The car will not perform the **Car Call Test** if it is on Independent Service Mode.



When performing the **Car Call Test** with the AUTO DOORS switch set to OFF, it is recommended to set the NON-INTERFERENCE TIME to at least 5 seconds. From the LCD interface, navigate to **Adjustable Variables => Car Timers**, and then set NON INTERFER T = 5.



### 5.1.6 Inputs & Outputs

---

Inputs and outputs are shown as a “1” for ON and a “0” for OFF. A list of all inputs and outputs used on the controller, and on specific boards, is shown in Section 4 of this manual, “Troubleshooting”. The controller determines which boards are used, depending on the options selected and the number of front and rear floors specified by the configuration files. The **Input and Output** Menu has submenus to access the car, group, Safety Processor, and NTS Processor I/Os. All I/O locations are determined from an *io.dat* file on the SD Card. I/Os in lines 0-13 and 138-146 of the *io.dat* file are specific hardware dependent locations, and their table locations should never be changed.

### 5.1.7 Job Statistics

---

#### **Job Statistics:**

The **Job Statistics** Menu shows the number car calls and the number and percent of hall calls serviced since the job was started, or since the job statistics were cleared. Listed on the right are all the call categories maintained:

- Number of Car Calls
- Number of Up Hall Calls
- Number of Down Hall Calls
- Number of Up Hall Calls with < 15 second wait time
- Number of Up Hall Calls with < 30 second wait time
- Number of Up Hall Calls with < 45 second wait time
- Number of Up Hall Calls with < 60 second wait time
- Number of Up Hall Calls with > 60 second wait time
- Number of Down Hall Calls with < 15 second wait time
- Number of Down Hall Calls with < 30 second wait time
- Number of Down Hall Calls with < 45 second wait time
- Number of Down Hall Calls with < 60 second wait time
- Number of Down Hall Calls with > 60 second wait time
- Percent of Hall Calls with < 15 second wait time
- Percent of Hall Calls with < 30 second wait time
- Percent of Hall Calls with < 45 second wait time
- Percent of Hall Calls with < 60 second wait time
- Percent of Hall Calls with > 60 second wait time

### 5.1.8 Adjustable Variables

---

The **Adjustable Variables** Menu allows modification of all field adjustable parameters for the Main CPU, the Safety Processor, and the NTS Processor. Refer to the Adjustable Variables section of this manual for a list of all parameters and their functions.

### 5.1.9 Car Timers

---

This is an example of an **Adjustable Variables** Submenu. Other Adjustable Variable submenus will be similar.

### 5.1.10 Date and Time

---

It is important to set the date and time on the controller clock, so that the fault log shows the correct time stamp and sequence as faults occur.

### 5.1.11 Diagnostics

---

The **Diagnostics** Menu shows the communications status for all serial devices. For most of these devices, the firmware version and the transmit/receive counts are displayed. The transmit/receive counts should be incrementing continuously for all serial devices while the device is communicating. All CAN bus communications ports show *TxErr* and *RxErr* counts, which ideally should show as zero. A non-zero error count on a CAN channel, or a non-incrementing receive counter on any serial channel, indicates a poor cable connection, or the presence of electrical noise on the cable. The **Diagnostics** Menu also contains a *VIEW SYSTEM STATUS* display that logs changes in elevator faults, status, and service.

The following is a list of all submenus of **Diagnostics** that are useful for troubleshooting status and communications issues within the system.

Boards, systems, and other controllers can be checked here for proper communications (On-Line) and for referencing firmware versions. These submenus are as follows:

- **View System Status Log**
- **Group Comm Status**
- **Group CAN Comm Status**
- **Car CAN Comm Status**
- **Machine Room CAN Comm Status**
- **Safety CAN Comm Status**
- **Drive Comm Status**

### 5.1.12 Software Utilities

---

The **Software Utilities** Menu allows the user to view the controller's software version, run Power-Up Mode, test the CPU watchdog timer, access SD Card operations, and to preset all limit velocity values.

**View Software Version:** Display the software version, revision and interim revision in the form 7.00.31.

**Run Power-Up Mode:** The Power-Up Mode is a program that executes first upon power up of the controller. It checks that there is a valid controller program in memory, and that a valid *cons.dat file* is on the SD Card. Once this is validated, the power up program runs the controller program. If the power up program is executed from the controller program, or if during power up, the user presses and holds the *ENTER* and *MODE* buttons. This routine does not run the controller program but stays in the power up routine, to allow for updates of the controller program. The Power-Up Mode is also used to upload new controller software from the SD Card to the Main CPU, the Safety Processor, and the NTS Processor.

**Test Watchdog Reset:** The watchdog is a CPU timer whose software must be updated periodically to confirm that the Main CPU program is still running correctly. If the watchdog is not updated, the timer will expire and cause the Main CPU to do a hard reset, to allow the program to restart. To test the watchdog timer, when the command is given, the controller program sits in an infinite software loop without updating the watchdog time to test that the reset function works.

**Reset Debug Variables:** The debug variables are set by a software engineer to aid in debugging a software problem. Some problems are especially difficult to catch because they occur infrequently or at random. The debug variables are displayed in the detailed **Elevator Status** Menu so that elevator personnel can view the variables and report back to the software engineer. The **Reset Debug Variables** menu allows elevator personnel to reset the variables to zero, to aid in the debugging.

**SD Card Read/Write Data:** This menu item allows the user to read and write controller data to and from the SD Card. This menu is explained in detail in the next section.

**SD Card Status:** This is the Secured Digital Card Status that shows if the card has been initialized (*Init=1*), if it is standard (*HC=0*) or High Capacity (*HC=1*), and if it can operate at an acceptable voltage level (*VStat=1*).

5.1.13 Power-Up Mode

When the Main CPU powers up, it runs a power-up routine that verifies the checksum of the controller program in local flash memory, and then verifies that the job configuration file is on the SD Card. If the checksum and job configuration file are okay, the power-up routine jumps to the controller program. If the power up does not pass these verifications however, the program control stays in the power-up routine and the elevator is not allowed to run. To enter power-mode (run the power-up routine), cycle the power while pressing the *ENTER* and *MODE* buttons on the LCD Display Interface, and then release the button when the display indicates to do so. Alternately, power up mode can also be entered by placing the car on inspection and selecting the **Run Power-Up Mode** Submenu item located in the **Software Utilities** Menu.

5.1.14 Update / Verify Program

This menu is used to check the integrity of the CONS file, the controller program, and the SD card itself. The **Update/Verify Program** Menu is also used to update the controller software. Whenever the software is to be updated, the controller must be booted without an SDCard, and when the Power-Up Mode Screen appears, the SD card can be inserted, the software can then be updated through entering **Update/Verify Program => Load Program from SDCard** Submenu.

5.1.15 Select Video Display

This menu allows you to select different video display screens when a machine room monitor is installed on the controller. If the monitor is installed on a non-dispatcher car, then only information for that car is displayed on the monitor.

5.1.16 Service Activation Timers

All services have either an input that triggers them or a condition that activates them. The **Service Activation Timers** could be used in addition to these inputs. The timers will allow a feature to be turned on during specific times of the day, without the need of a specific condition or switch operation. All GALaxy traction and complex hydro controllers have service activation timers built in. Up to ten different timers (TIMER0 to TIMER9) can be programmed.

The timers listed below will turn on services that will run only during predefined times set by elevator users. At this moment, there are fourteen such services:

<b>Parking</b>	<b>Alternate Lobby</b>	<b>Group Car Call Override</b>
<b>Alternate Parking</b>	<b>Alternate Floor Security</b>	<b>Sabbath</b>
<b>Next Up</b>	<b>Car Call Lockouts</b>	<b>CC Push Button Security</b>
<b>Up Peak</b>	<b>Group Car Call Lockouts</b>	<b>Floor Security Table 2- 4</b>
<b>Down Peak</b>	<b>Car Call Override</b>	

There are two types of time settings that can be used to determine when the timers will run:

(1) **Day of the Week:** This will allow you to turn services ON and OFF for each individual day of the week. This is a total of seven ON and OFF time settings.

(2) **Month and Day:** This will allow services to run only on the date on which they are set. There are three on and off settings for this type.

The **Day of the Week** setting will be the most common setting for most service timers. However, **Month and Day** timers can be useful for programming special events or holidays. Setting the **Day of the Week** timer makes the selected service run repeatedly every day. Month and Day timers will run only once a year.

Programming the timers can be done through the LCD interface or the Galileo Interface. Once the timers are programmed, you could disable or enable the timer without modifying any of the settings. In other words, a timer could be programmed completely, and stay disabled until the building is ready for implementation. At that point you would simply turn it on.

#### 5.1.17 Display Hoistway Table

---

This menu is useful for checking the encoder direction by watching the encoder for the direction of the pulse counts. Once the hoistway is learned, the pulse count values for each floor will be displayed. If the pulse count for each floor is zero (does not increase or decrease), the hoistway has not been learned or the floor counts have not been retained in memory. The velocity displayed is the speed of the car as read from the car's position feedback system. The top line shows current pulse count which can be compared to the stored pulse count. The second line are the learned values.

Note that the first landing should have a higher pulse and distance count than the DN values, i.e. DN 0.0, first landing 0.1 (second line on the right). It is possible to adjust the pulse count slightly, but it is recommended that the magnets be moved and the hoistway relearned.

#### 5.1.18 DZ & DZ Offset, Sel Cnt

---

This menu provides status information when using a CAN open encoder. It also allows the elevator personnel to adjust the DN LEV DIST and UP LEV DIST parameters in order to “fine tune” the floor levels after the car is running high speed. These parameters are valid when the STOP ON POS adjustable variable is enabled. Refer to the “Fine Tune The Ride Quality” in sections 3 for proper adjustment.

#### 5.1.19 FL & FL Offset Count

---

This menu allows elevator personnel to adjust the stored floor count for each floor level. It also allows offsets to be used to “fine tune” the floor levels after the car is running high speed. The FLOOR LEVEL OFFSET is valid when the STOP ON POS adjustable variable is enabled in Adjustable Variables => Car Motion. Refer to the “Fine Tune The Ride Quality” in Section 3 for proper adjustment.

#### 5.1.20 Reset Update Count Trig, Pulse Count Update Data

---

This menu is valid when the POS COUNT UPD variable is enabled in Adjustable Variables => Car Motion. When this variable is enabled, the DP count will be updated while the car is in motion. The **Pulse Count Update Data** Menu provides detailed information in order to properly set this variable. The **Reset Update Count Trig** Menu allows the elevator personnel to manually reset the “Update Trigger”.

#### 5.1.21 Elevator Setup

---

From this menu, the user can select to set all the speed clamps, learn the hoistway, run an overspeed test, run a car buffer test or run a counterweight buffer test, open and close the doors on inspection and setup the load weigher.

#### 5.1.22 Match Feedback Velocity & Direction

---

This operation is part of the setup procedure of the elevator to match the velocity and direction of the three main control CPUs, the Main CPU, Safety Processor and NTS Processor. The mechanic is instructed to run the car up on Machine Room Inspection. While the car is running up, the Main CPU will monitor the speed and direction of all three devices and make the appropriate parameter changes to correct for any differences. Note that the Main CPU will indicate to release the inspection run in order to update parameters for the NTS or SPB processors. If the velocity or direction cannot be corrected, the Main CPU will display status information so the mechanic can make the necessary correction.

---

### 5.1.23 Auto Learn Hoistway

---

This operation is used to automatically learn the hoistway on initial setup. From the LCD Interface, select the **Elevator Setup** Menu, use the up or down button to select the **Learn Hoistway** item, and then press *ENTER*. Follow the directions displayed for each step. Learn Hoistway can be initiated with the car located anywhere in the hoistway but is usually best to run the car to the bottom first.

---

### 5.1.24 Inspection Learn Hoistway

---

This operation is used to manually learn the hoistway on initial setup. From the LCD Interface, select the **Elevator Setup** Menu, use the UP or DOWN button to select the **Learn Hoistway** item, and then press *ENTER*. Follow the directions displayed for each step. Learn Hoistway can be initiated with the car located anywhere in the hoistway, but is usually best to run the car to the bottom first.

---

### 5.1.25 Learn Limit Velocities

---

This operation is used to setup the clamp values or trip velocities for the Main CPU, Safety Processor, and NTS Processor for the appropriate terminal limits. From the LCD Interface, select the **Elevator Setup** Menu, use the *UP* or *DOWN* button to select the **Learn Limit Velocities** item, and then press *ENTER*. Follow the directions displayed for each step. The **Learn Limit Velocities** procedure should be run only after the ride of the car is adjusted (acceleration and decelerations are set as desired).

---

### 5.1.26 Manually Setting Main CPU Speed Clamps

---

Once the car is running on Automatic Mode, the acceleration and deceleration rates are adjusted, and several runs have been made from the top to the bottom terminals at contract speed, the speed clamps can then be adjusted. Using the set speed clamp menus on the LCD interface, select the clamp to adjust and press *ENTER* to access the clamp setting. In the above illustration, the suggested setting is shown as the CLAMP SPEED and the actual clamp setting is shown as INS/ LEVEL SPD. The *ENTER* button is used to enter and exit the Edit Mode. Once in the Edit Mode, the *MODE* button selects the next digit to edit. The up and down buttons increment or decrement the clamp speed setting. All speed clamps are adjusted in the same manor. The speed clamps that can be adjusted are the inspection/leveling speed clamps, the Down and Up Terminal Slowdown speed clamps (DT/UT, DT1/UT1, DT2/UT2 and DT3/UT3) and the Down and Up Emergency Terminal Speed clamp (DTS/UTS).

See diagram for Elevator Setup for an example.

---

### 5.1.27 Inspection Open – Close Door

---

The menu allows elevator personnel to open or close the elevator doors from the up or down LCD interface buttons, while the car is on Inspection Mode.

---

### 5.1.28 Lift Brake on Inspection

---

The flowchart describes the steps for lifting the brake on inspection. **WARNING:** Brake will lift automatically during this test. **Make sure all safety procedures are observed.**

---

### 5.1.29 Loadweigher Setup

---

The loadweigher hardware is setup according to the manufacturer's instructions. The controller is then setup to read the empty and full load values at every floor.

---

### 5.1.30 Load Weigher View/Modify

---

In this menu the load limits can be modified.

### 5.1.31 Calibrate Load Weigher

---

This is the procedure for calibrating the loadweigher.

### 5.1.32 Counterweight & Buffer Test

---

The car and counterweight buffer test follow the same menu operation. For specific instruction on executing a buffer test, refer to Section 5.2.49 and Section 8.14.

### 5.1.33 Overspeed Test

---

The overspeed test disables the velocity check for the car traveling faster than 15% over contract speed. The mechanism is disabled for one run. See Appendix B for instruction on running an overspeed test.

### 5.1.34 Reset / View Faults

---

This menu allows the user to view or clear the fault log.

### 5.1.35 View Fault Log

---

The fault display shows the fault, the car position, time and date the fault occurred and the number of occurrences. Faults are displayed in the order of occurrence with the order number displayed on the top left. The largest order number signifies the last fault that has occurred. Faults are stored in a circular buffer that fits up to 50 faults. Once the buffer is full the next fault overwrites the oldest fault (lowest numbered fault). Refer to the system faults in the troubleshooting section of this manual for possible causes of the fault and a description of the detailed fault data.

### 5.1.36 Clear Fault Log

---

This operation clears the fault log. Once cleared, all faults will show “No Occurrences” until a new fault occurs.

### 5.1.37 Reset Gripper Menu

---

This shows the procedure for resetting a Gripper fault

## 5.2 LCD Menu Diagrams

### 5.2.1 Main Menu

#### LCD Interface Main Menu

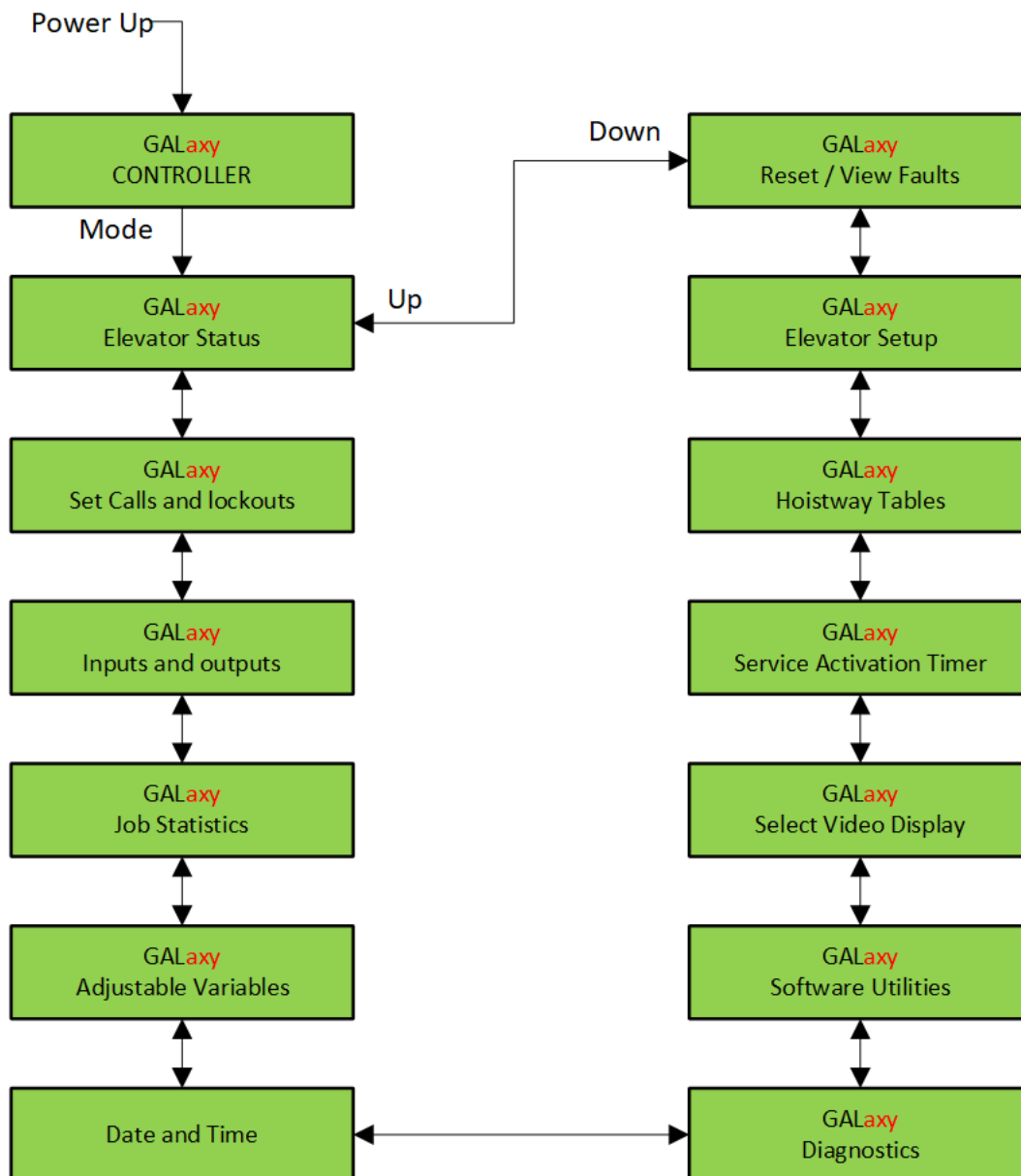

Figure 5-1: The Main Menu of the LCD Interface

5.2.2 Elevator Status

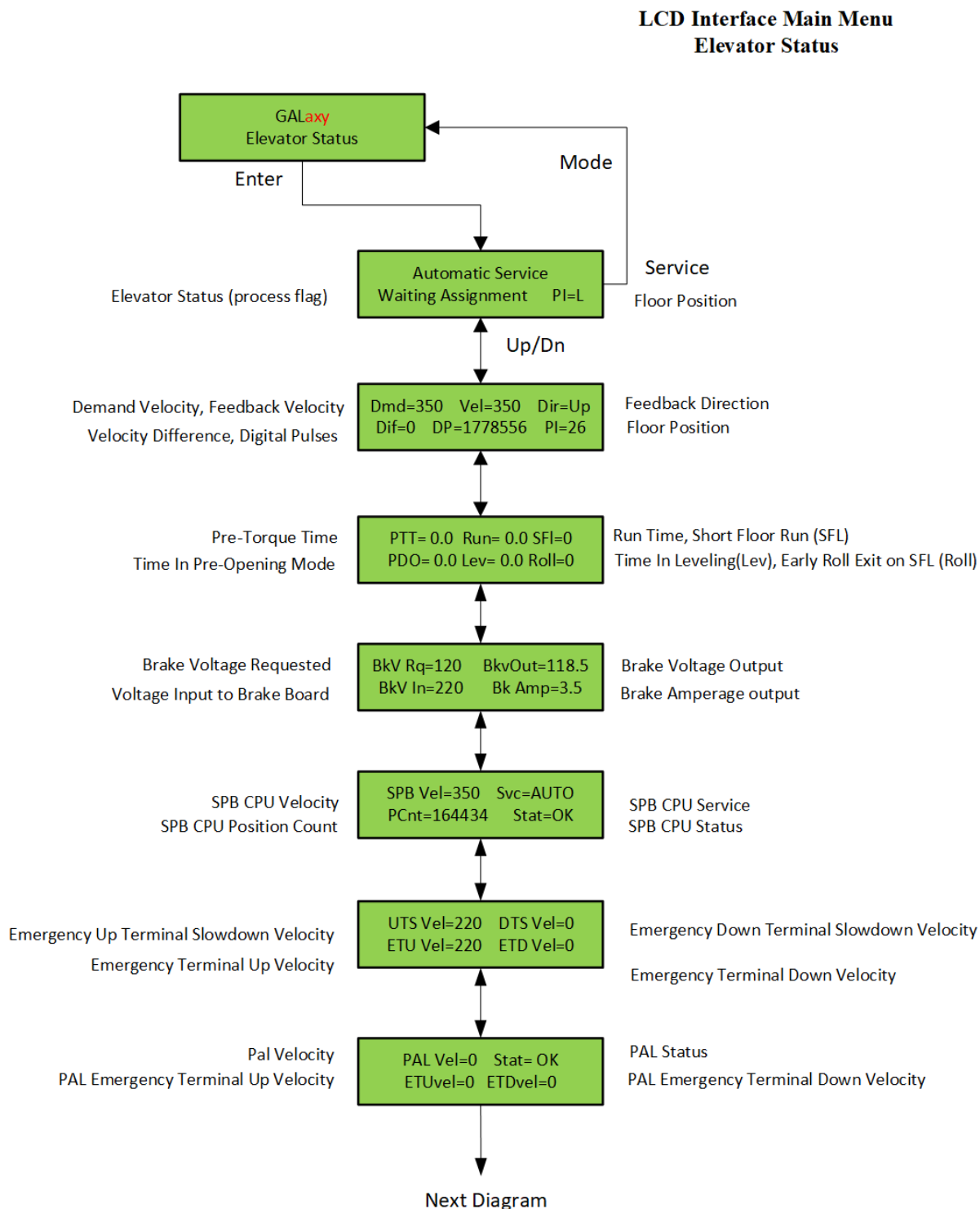
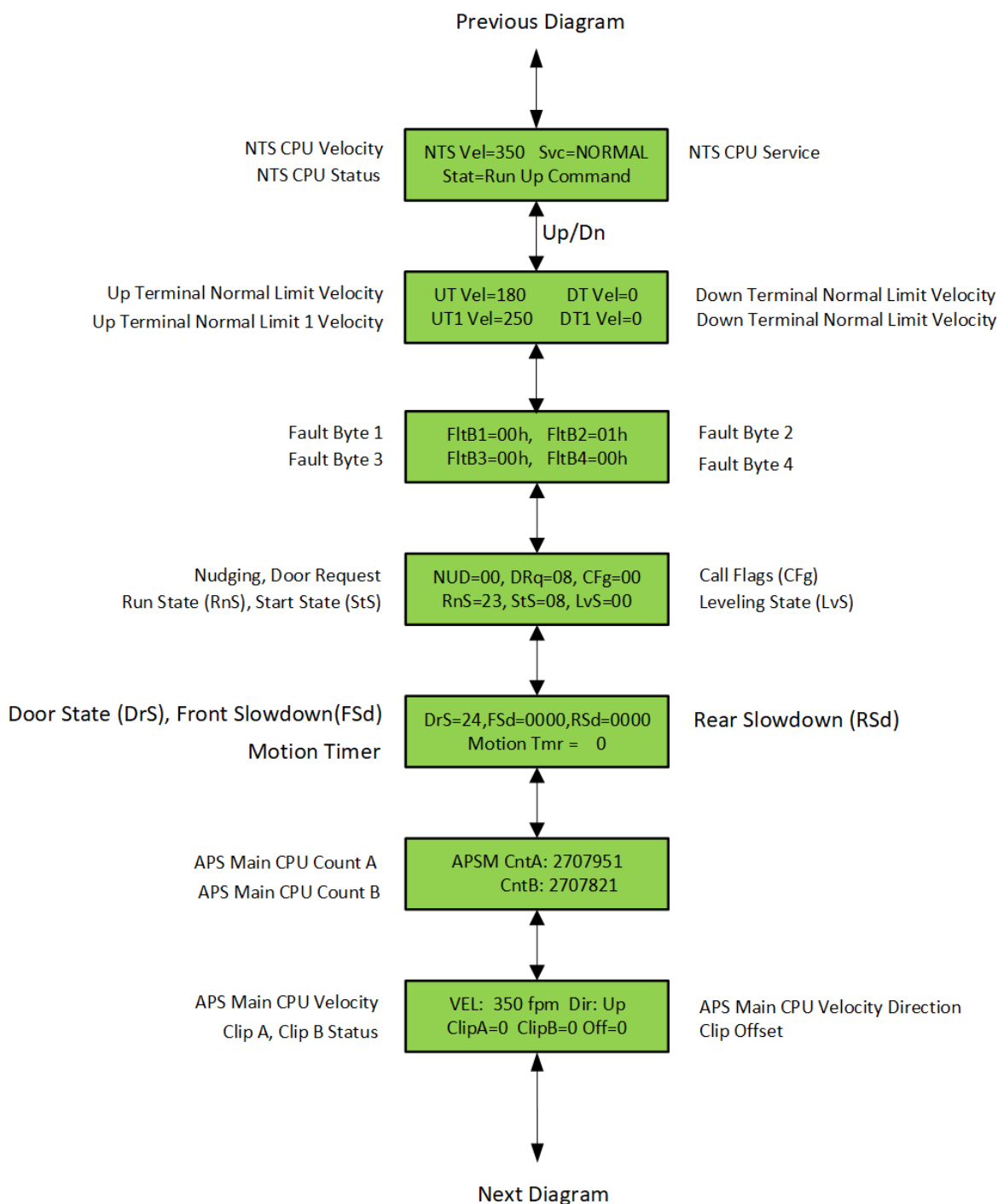

Figure 5-2 A: LCD Interface Main Menu – Elevator Status



**LCD Interface Main Menu  
Elevator Status  
Continued**



**Figure 5-2 B: LCD Interface Main Menu – Elevator Status**

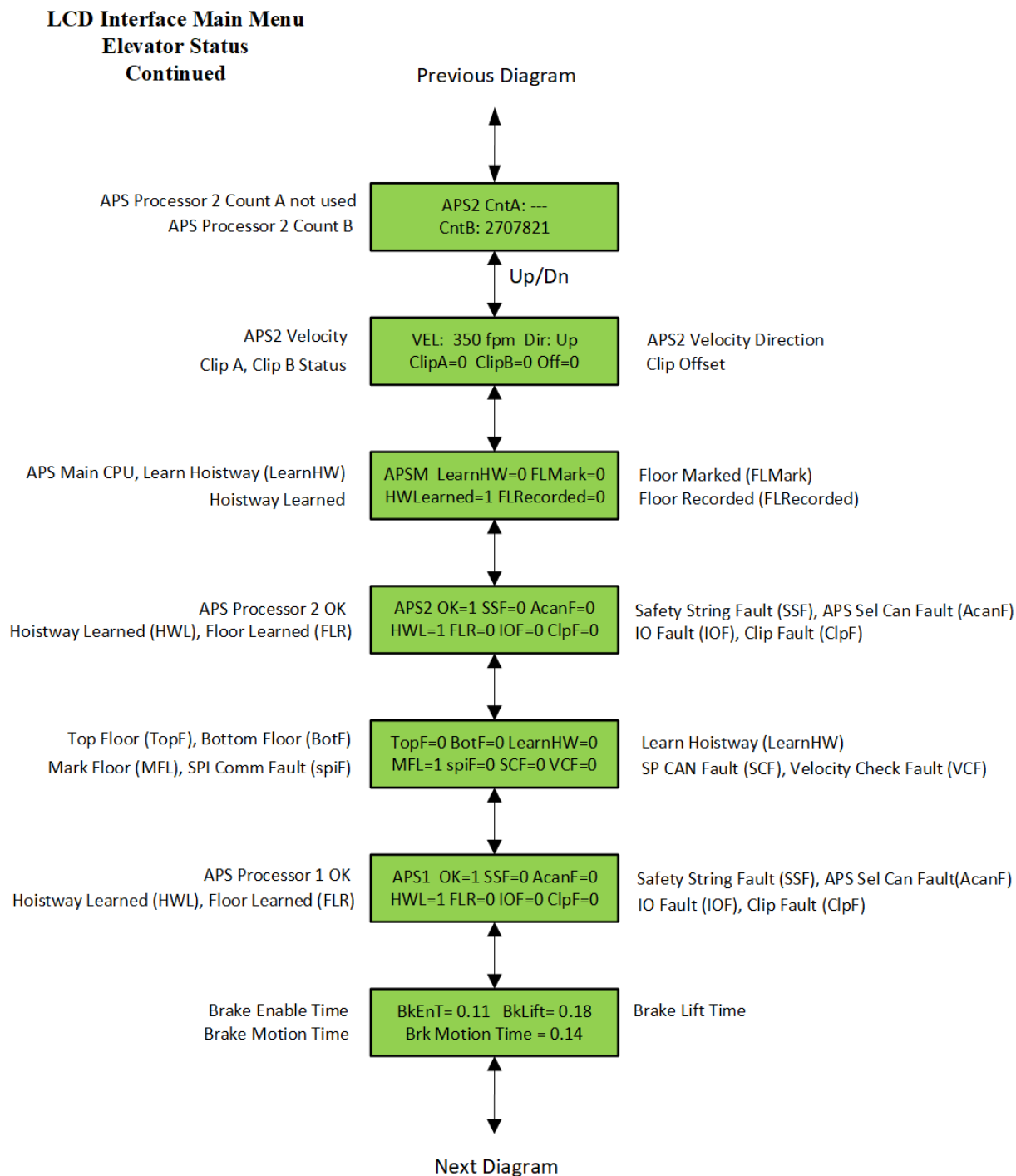

Figure 5-2 C: LCD Interface Main Menu – Elevator Status

5.2.3 Set Calls and Lockouts

**LCD Interface Main Menu  
Set Calls and Lockouts**

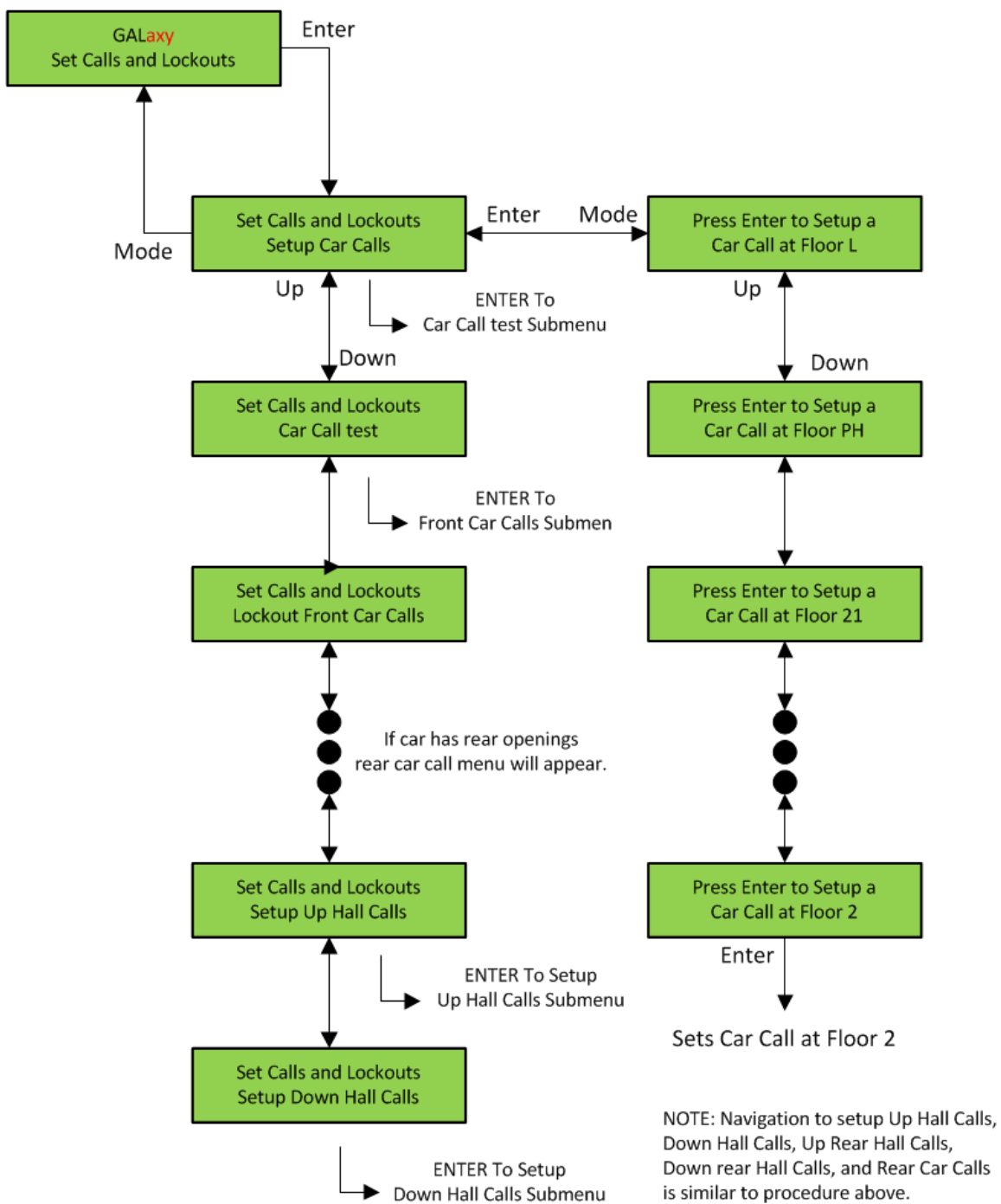

Figure 5-3: LCD Interface Main Menu – Set Calls & Lock Outs

5.2.4 Car Call Test

**LCD Interface  
Car Call Test Submenu**

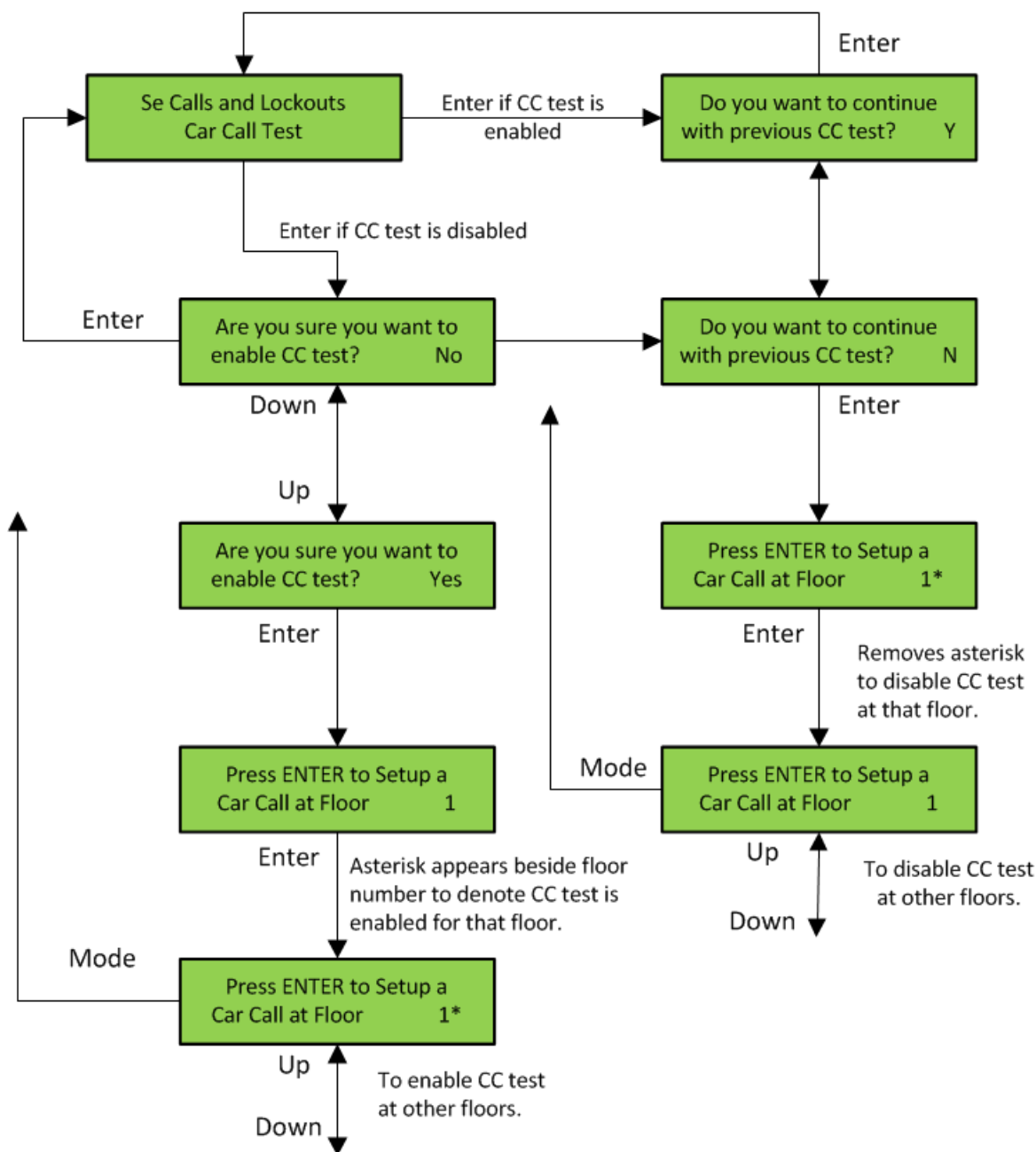

Figure 5-4: LCD Interface – Car Call Test Submenu

5.2.5 Lockout Front Car Calls

**LCD Interface  
Lockout Front Car Calls Submenu**

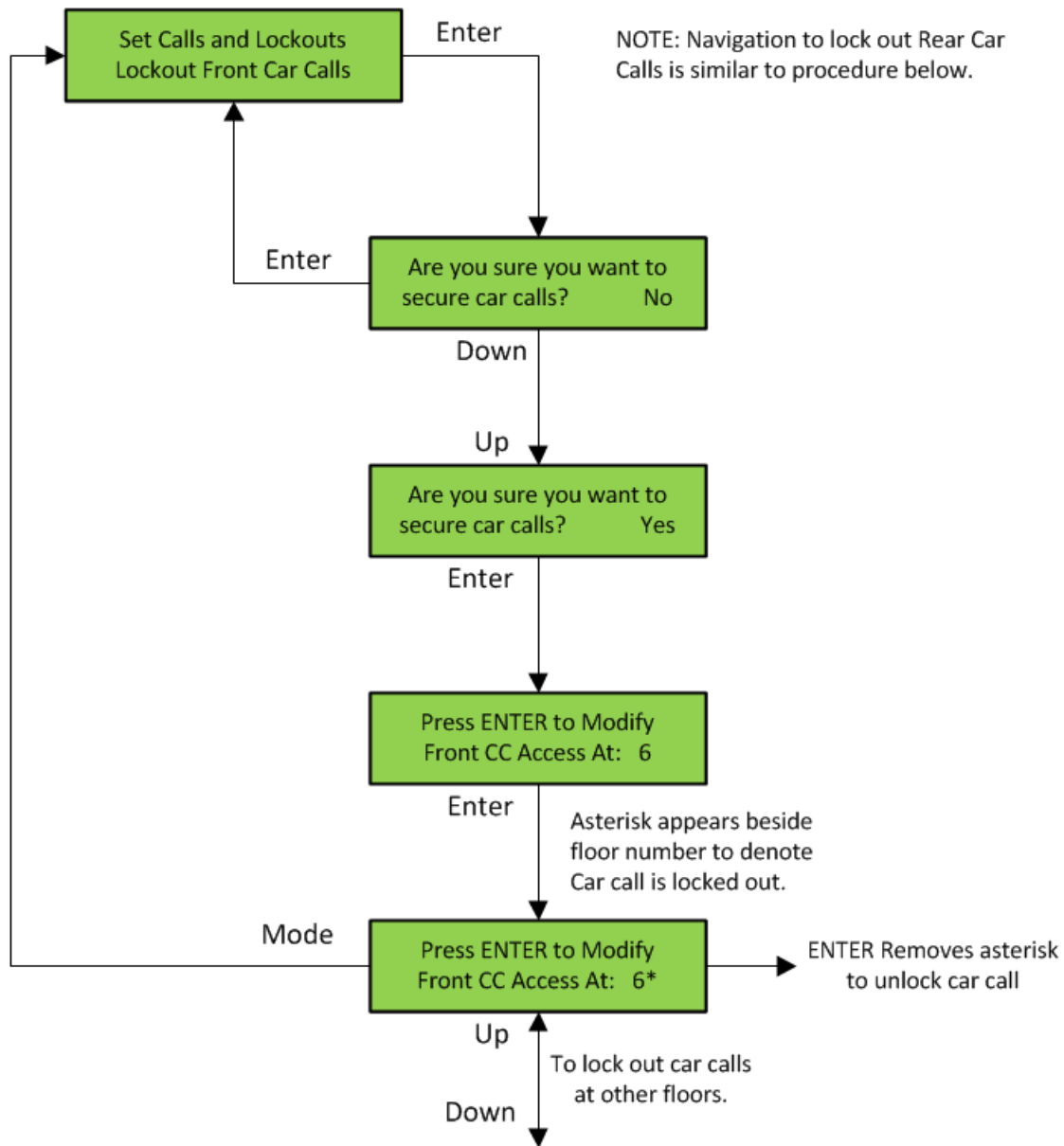

Figure 5-5: LCD Interface – Lockout Front Car Calls Submenu

5.2.6 Inputs and Outputs

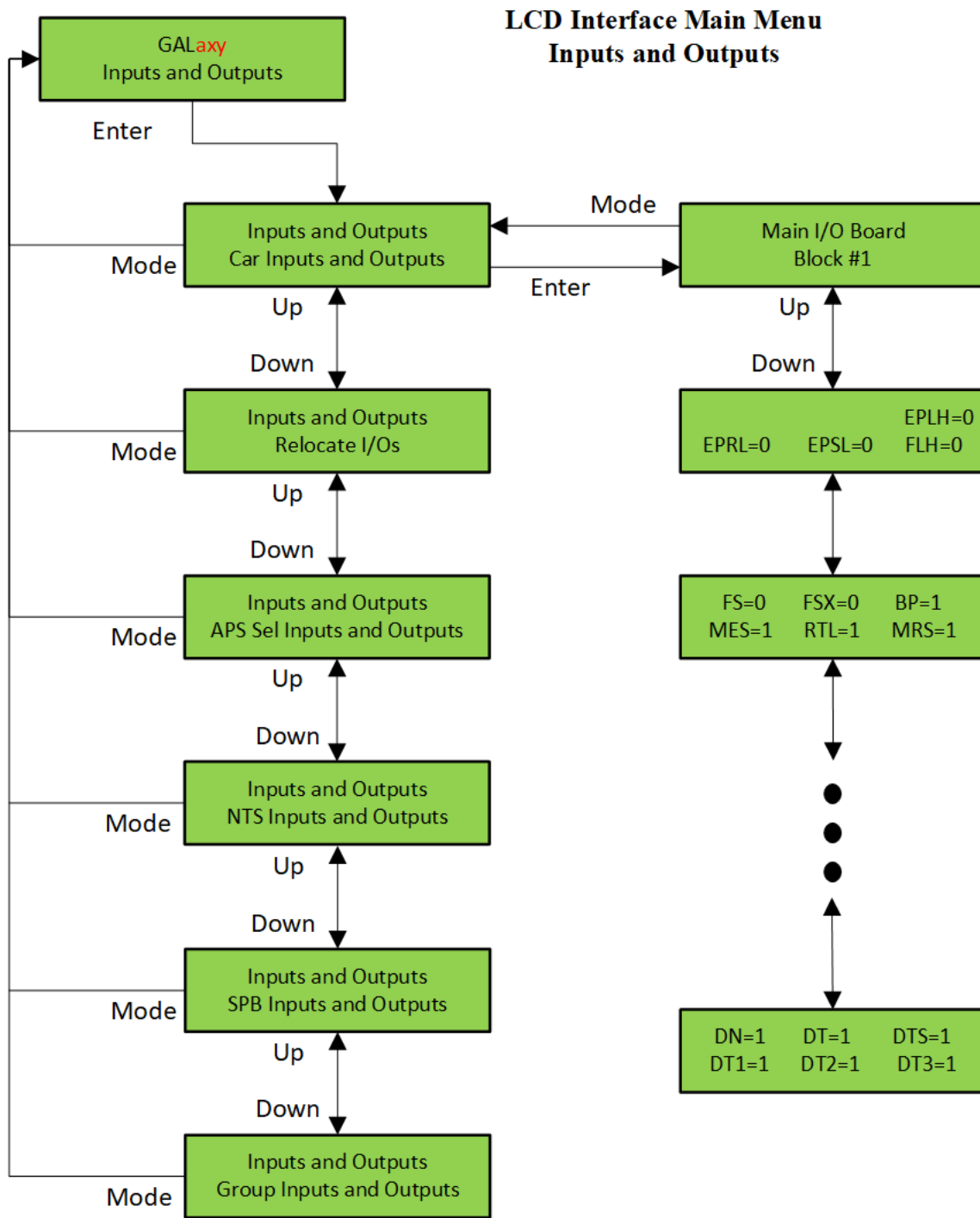

Figure 5-6: LCD Interface Main Menu – Inputs & Outputs

5.2.7 Relocate I/Os

**LCD Interface Main Menu  
Relocate I/Os**

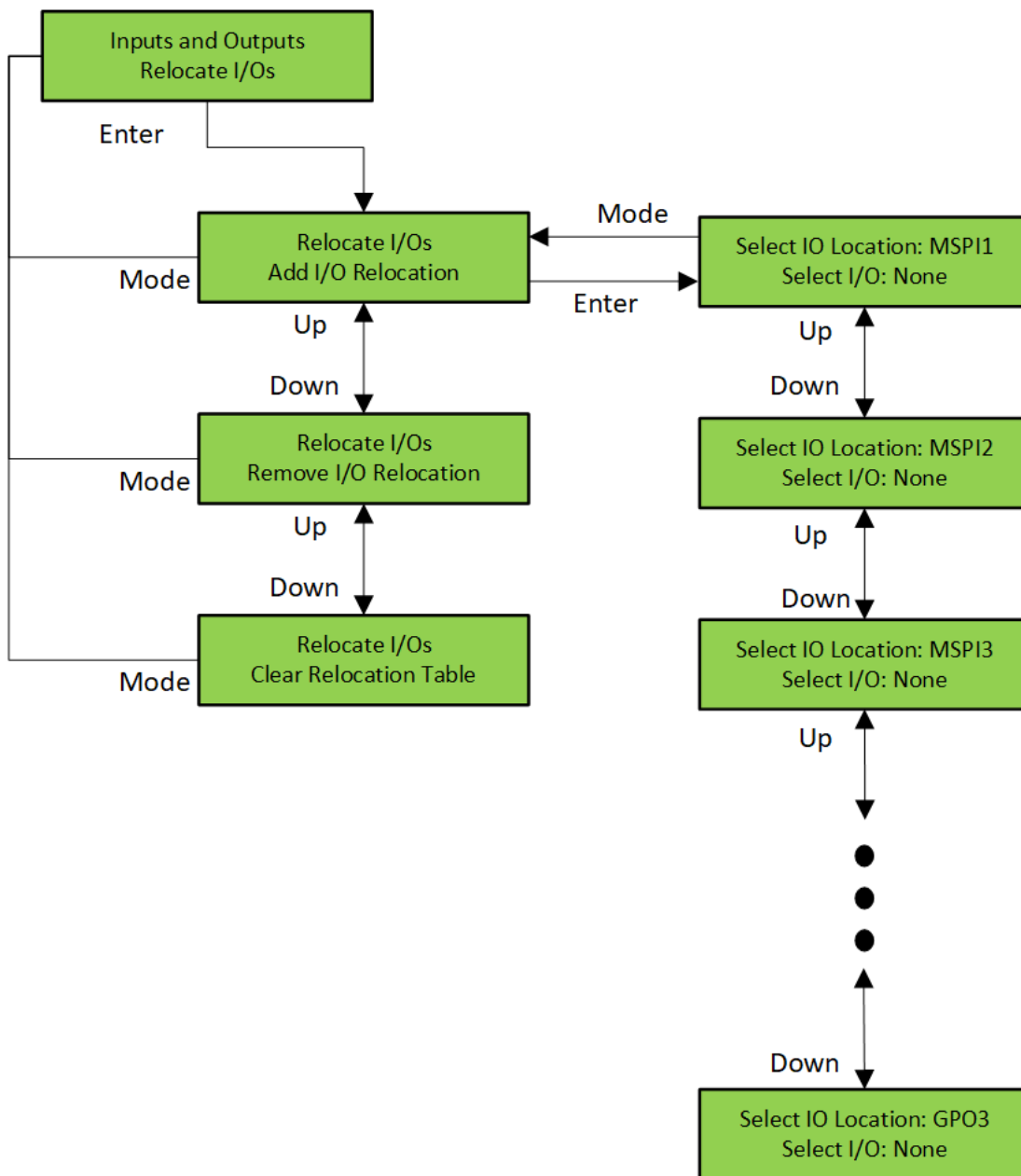

Figure 5-7: LCD Interface Main Menu – Relocate I/Os

5.2.8 Add I/O Relocation

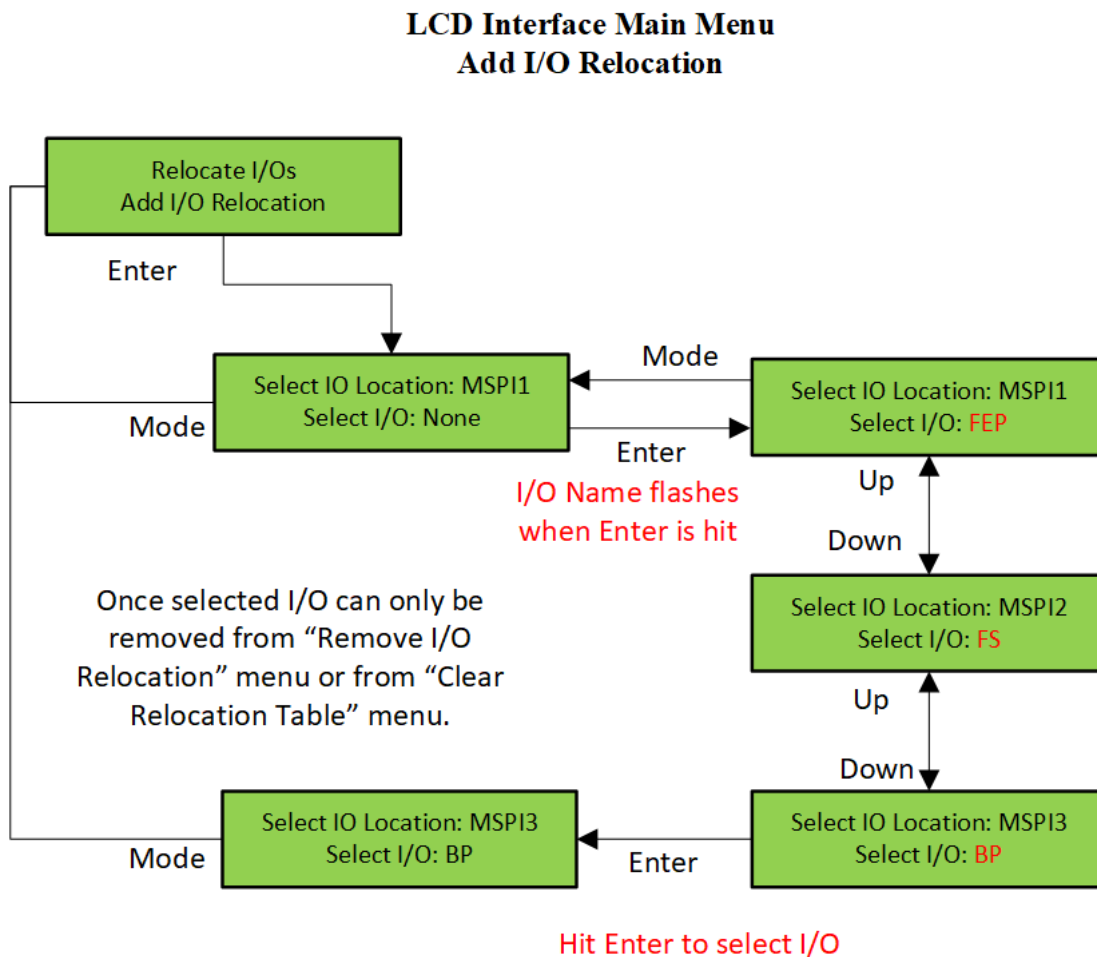

Figure 5-8: LCD Interface Main Menu – Add I/O Relocation



5.2.9 Job Statistics

**LCD Interface Main Menu  
Job Statistics**

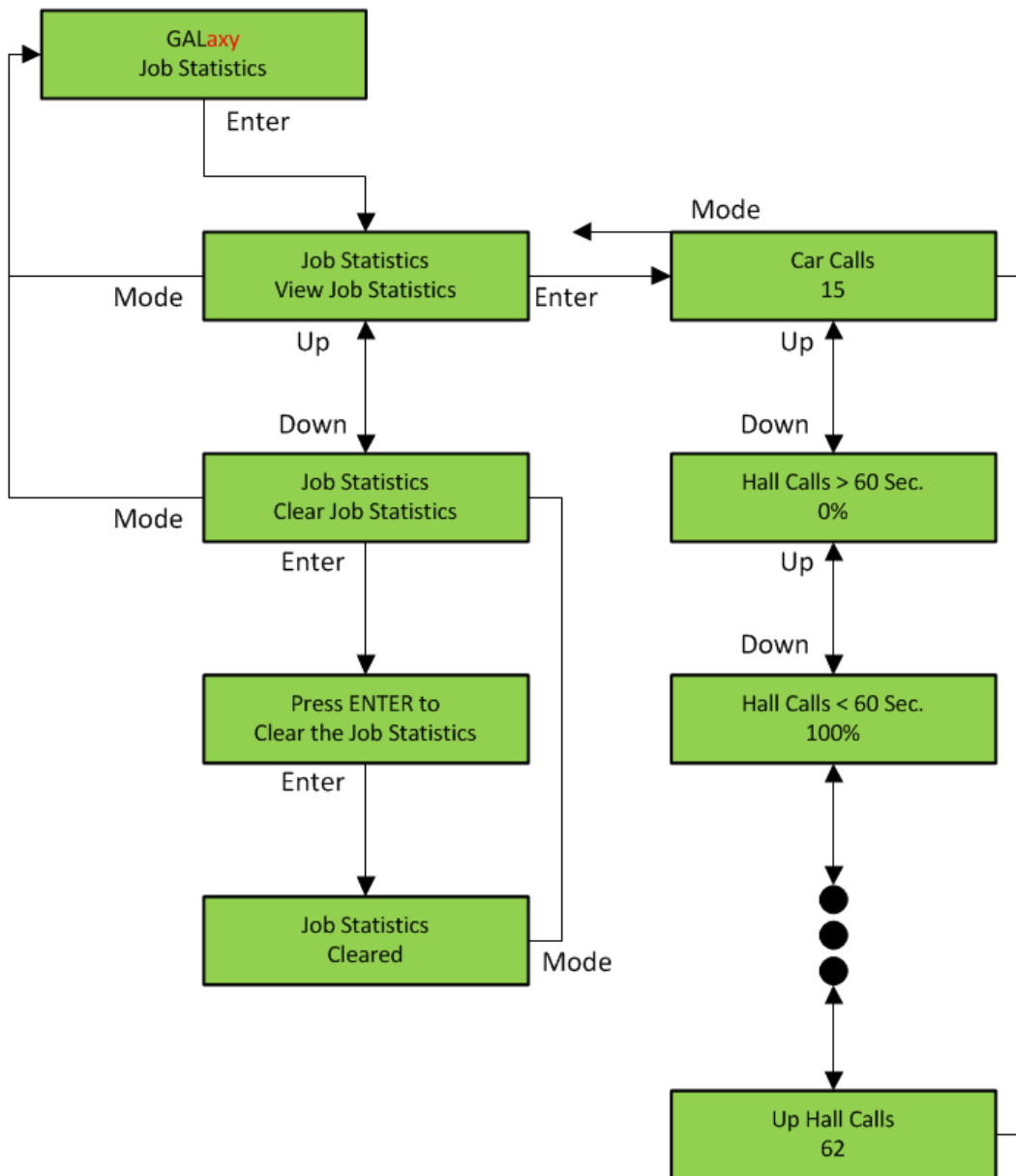

Figure 5-9: LCD Interface Main Menu – Job Statistics

5.2.10 Adjustable Variables

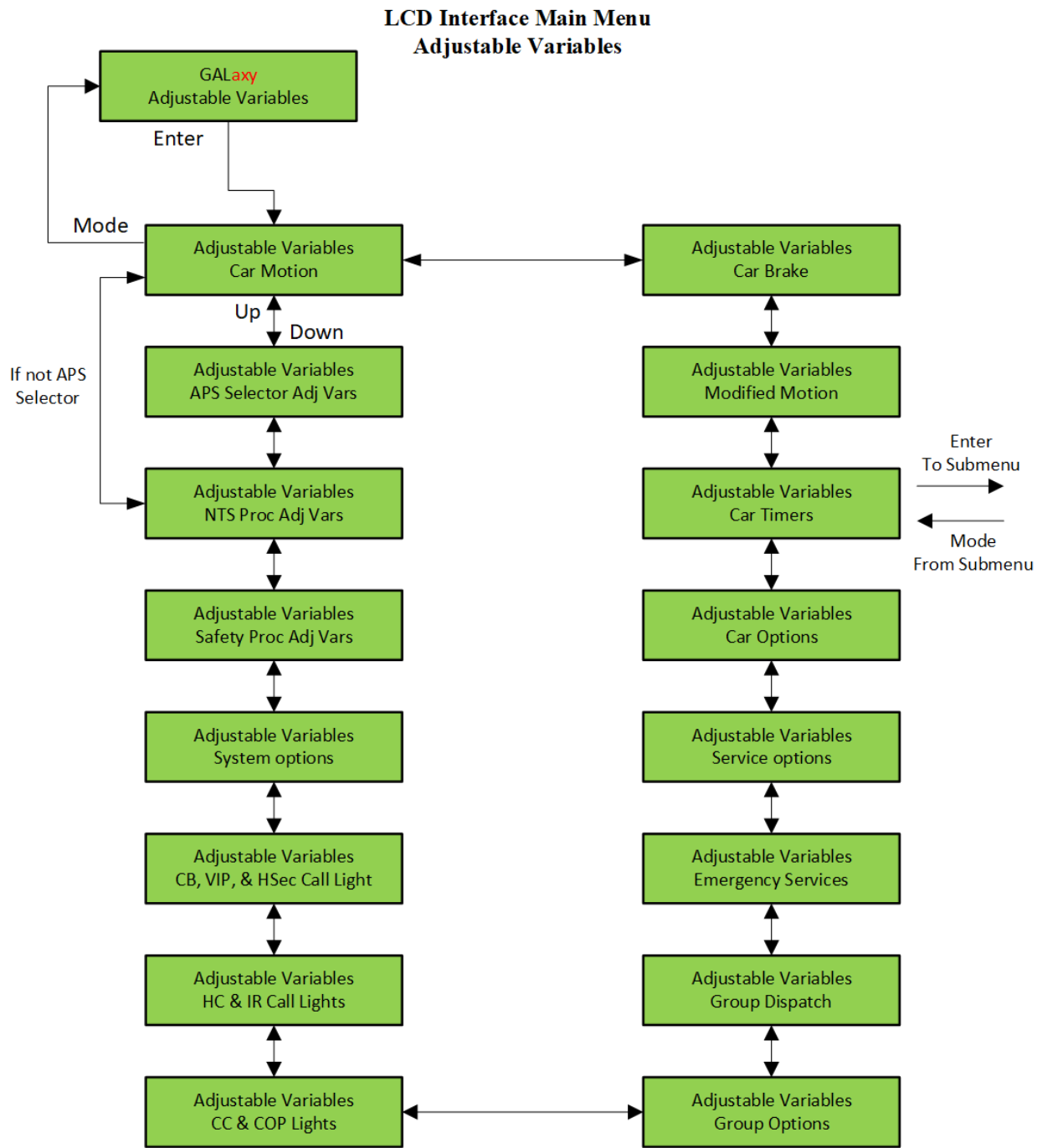

Figure 5-10: LCD Interface Main Menu – Adjustable Variables

5.2.11 Car Timers

**LCD Interface  
Car Timers Submenu**

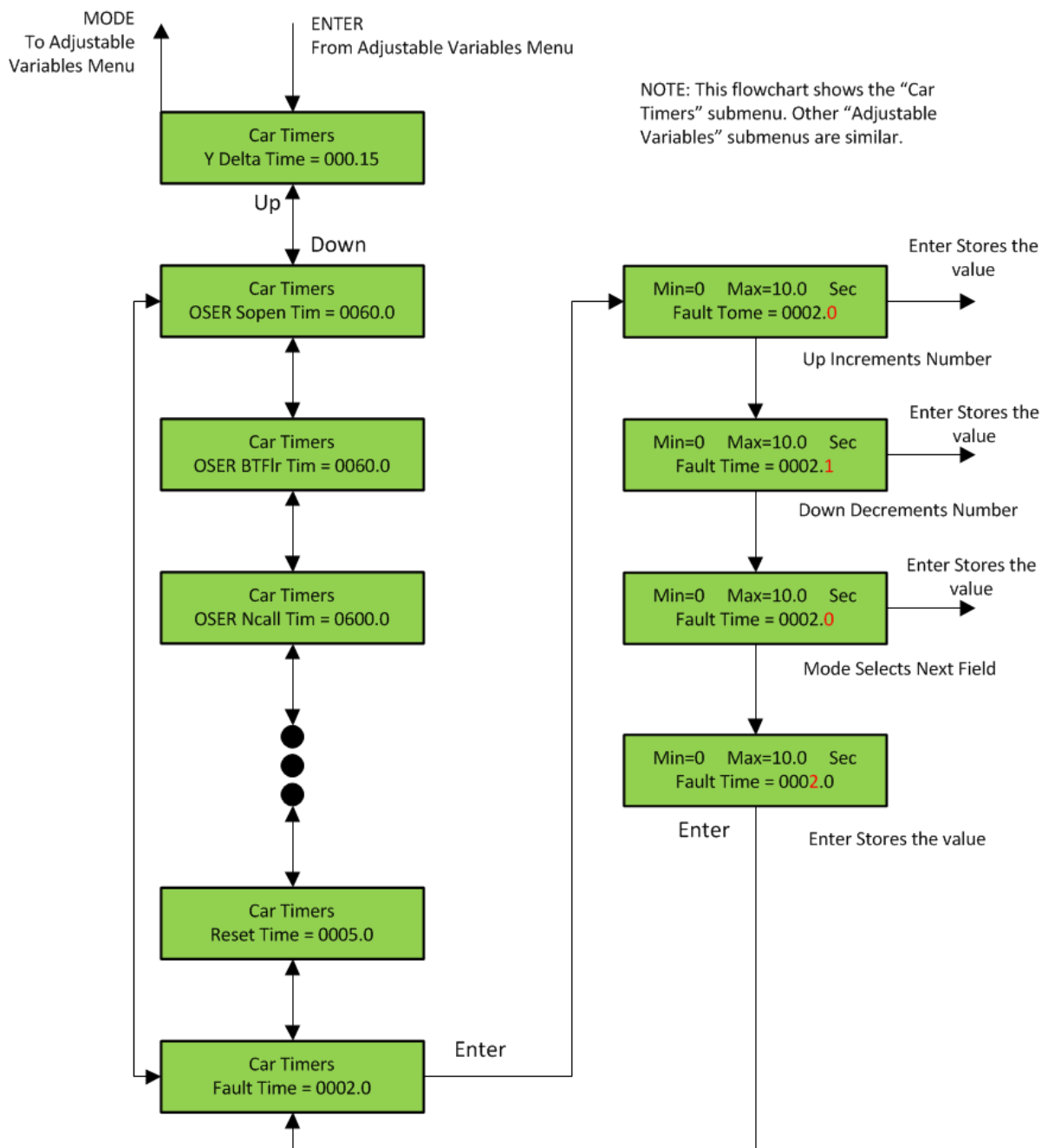

Figure 5-11: LCD Interface – Car Timers Submenu

5.2.12 Date and Time

**LCD Interface Main Menu  
Date and Time**

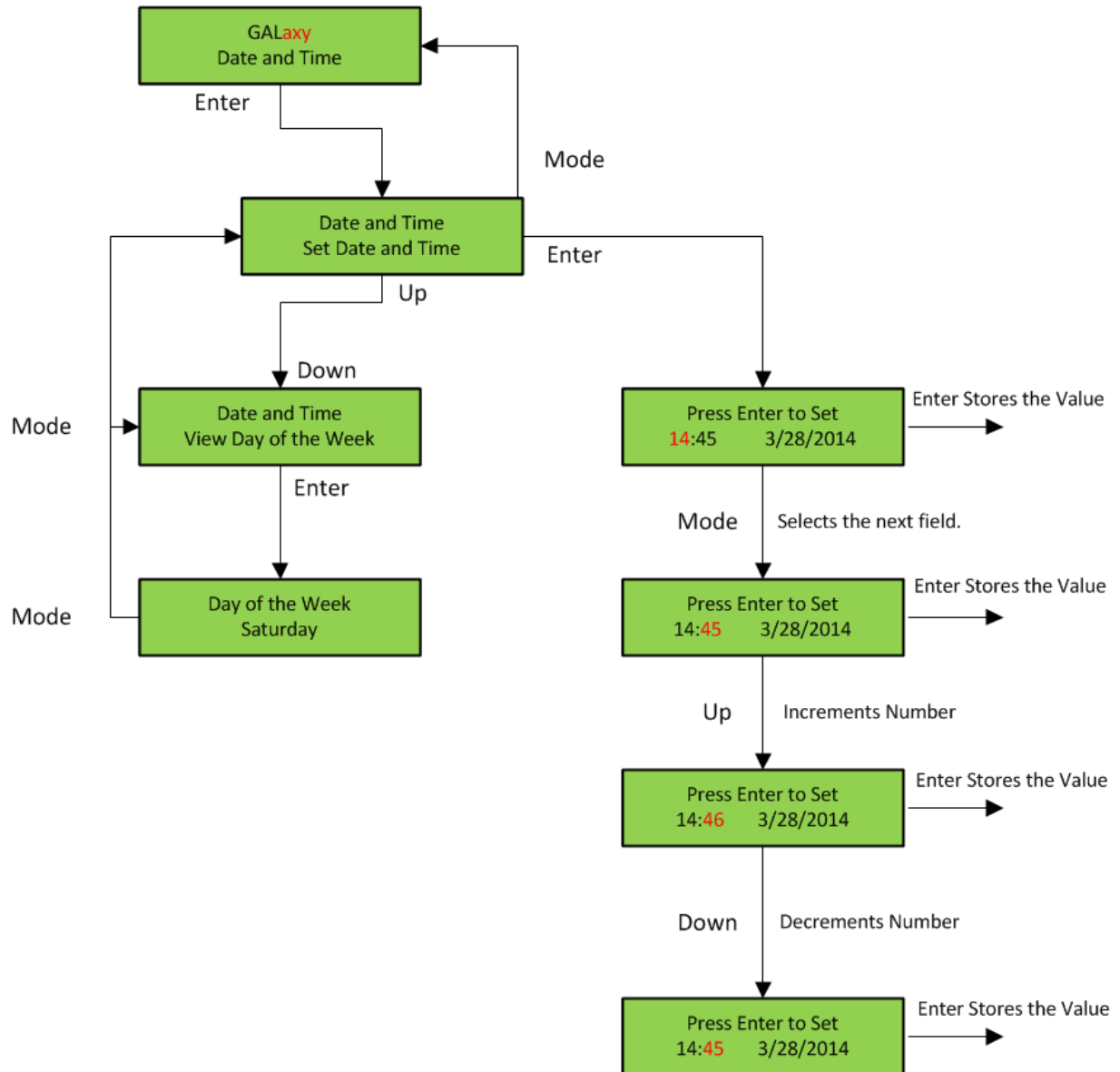

Figure 5-12: LCD Interface Main Menu – Date & Time

5.2.13 Diagnostics

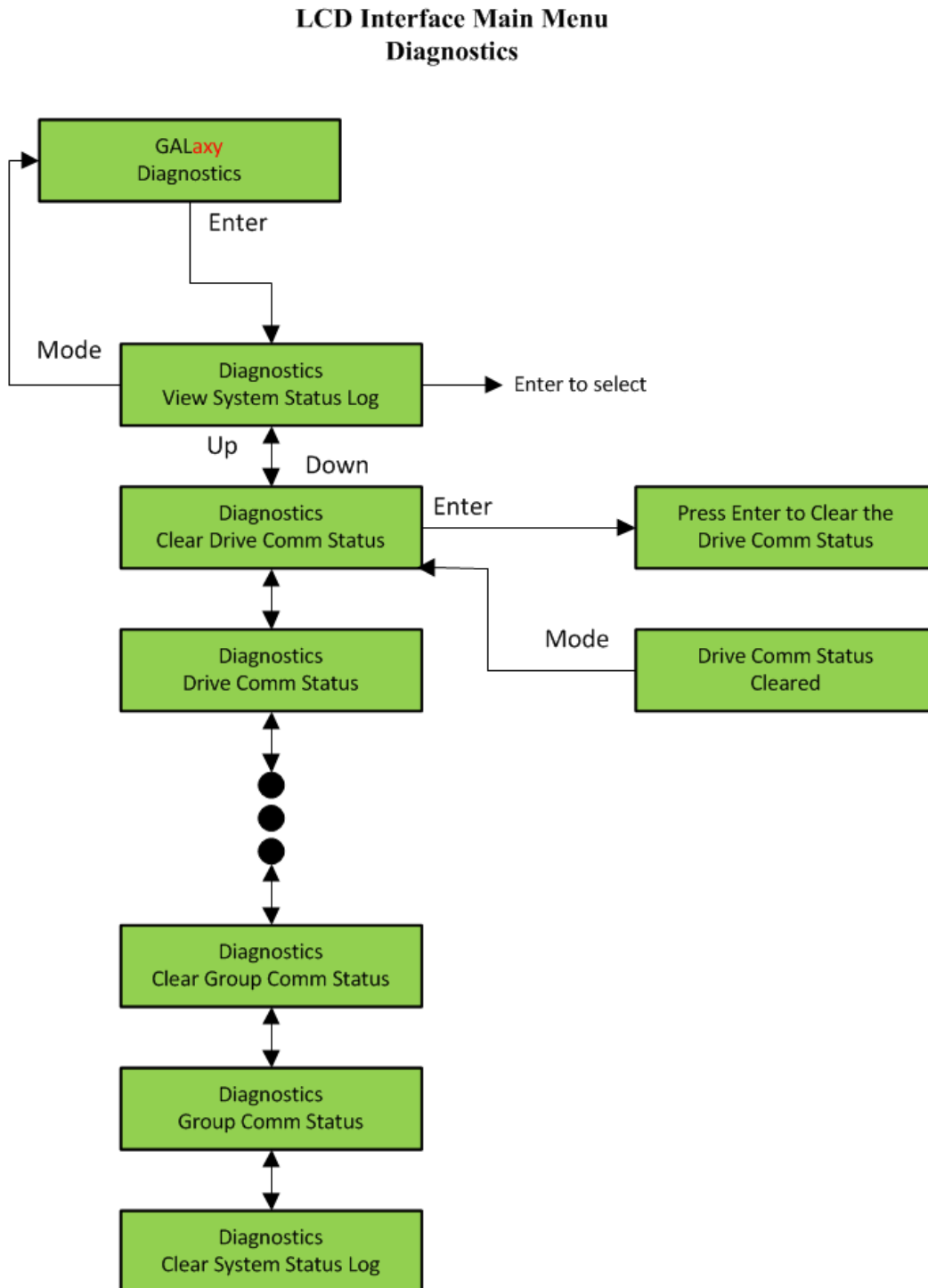

Figure 5-13: LCD Interface Main Menu - Diagnostics

5.2.14 View System Status Log

**LCD Interface  
View System Status Log Submenu**

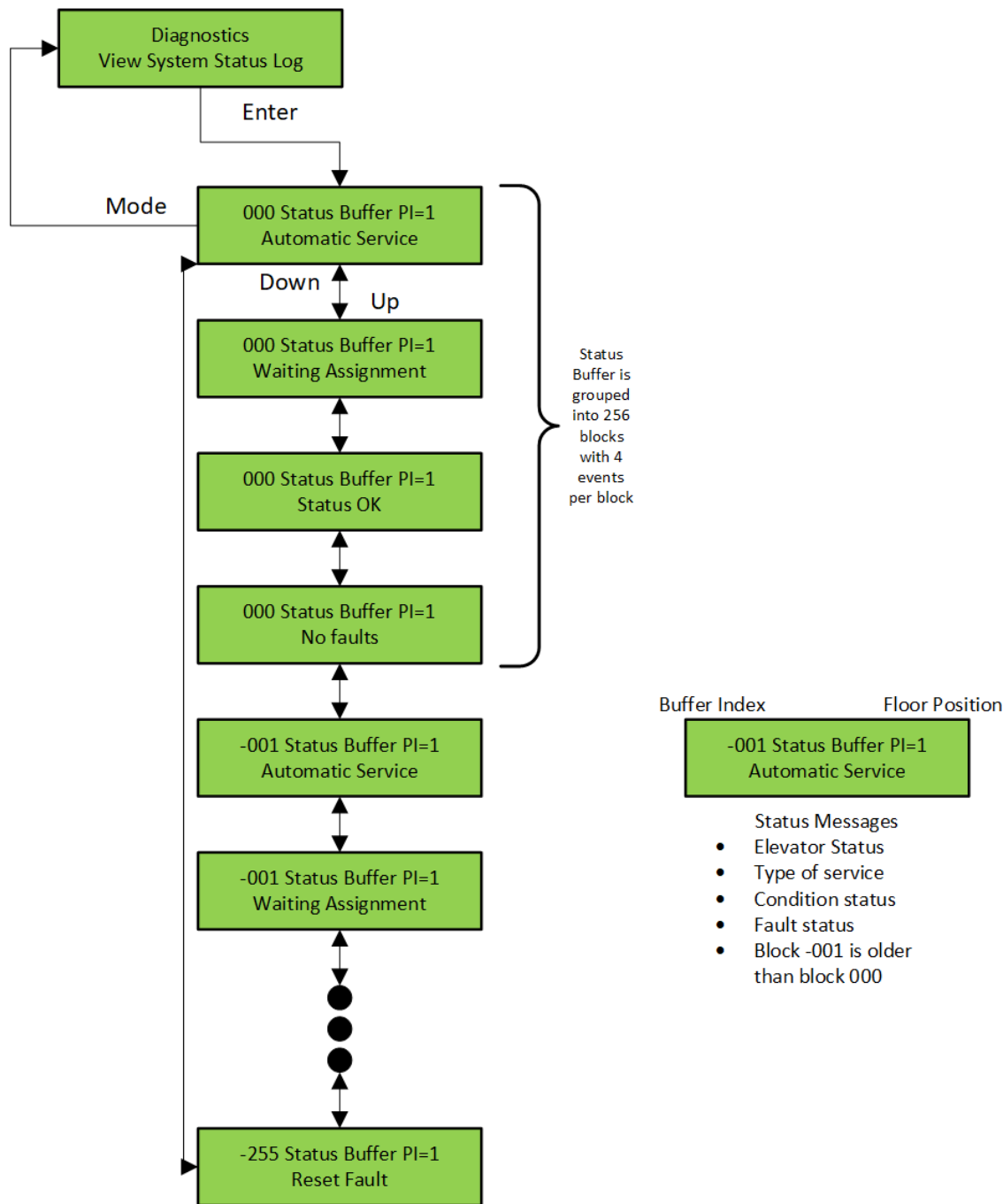

Figure 5-14: LCD Interface – View System Status Log Submenu

5.2.15 Group Comm Status

**LCD Interface  
Group Comm Status Submenu**

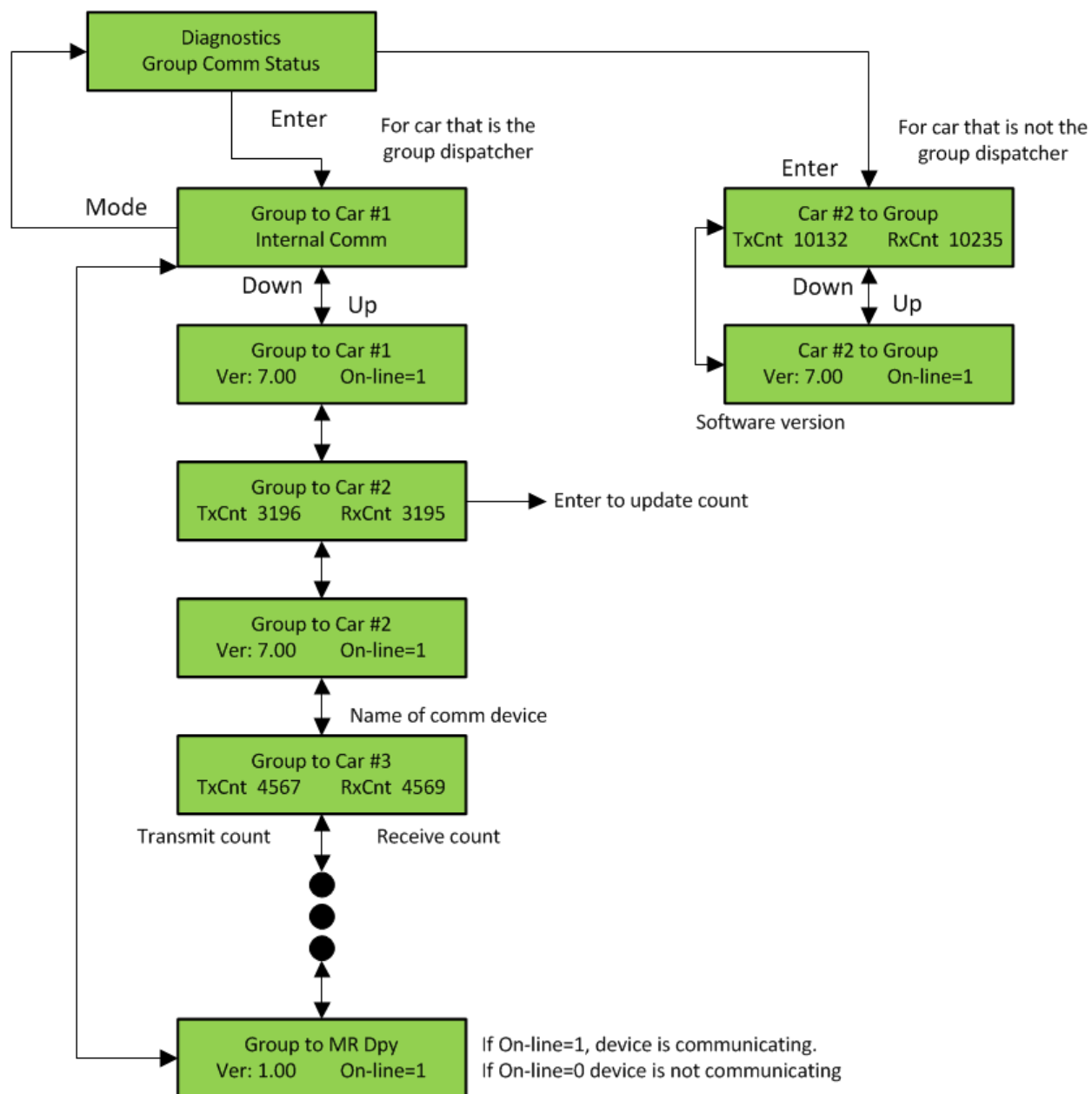

Figure 5-15: LCD Interface – Group Comm Status Submenu

5.2.16 Group Can Comm Status

**LCD Interface  
Group Can Comm Status Submenu**

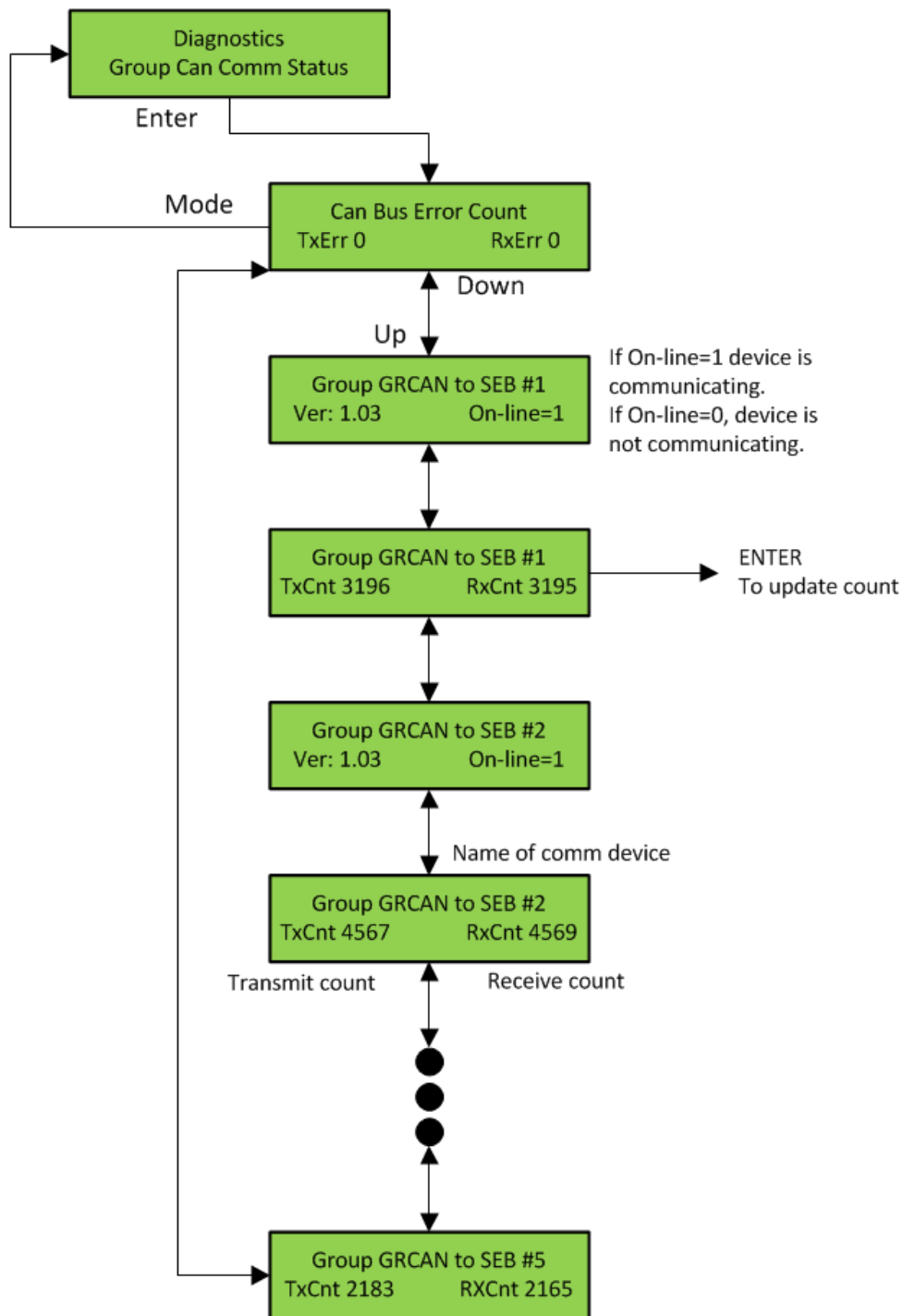

Figure 5-16: LCD Interface – Group Can Comm Status Submenu



5.2.17 Car Can Comm Status

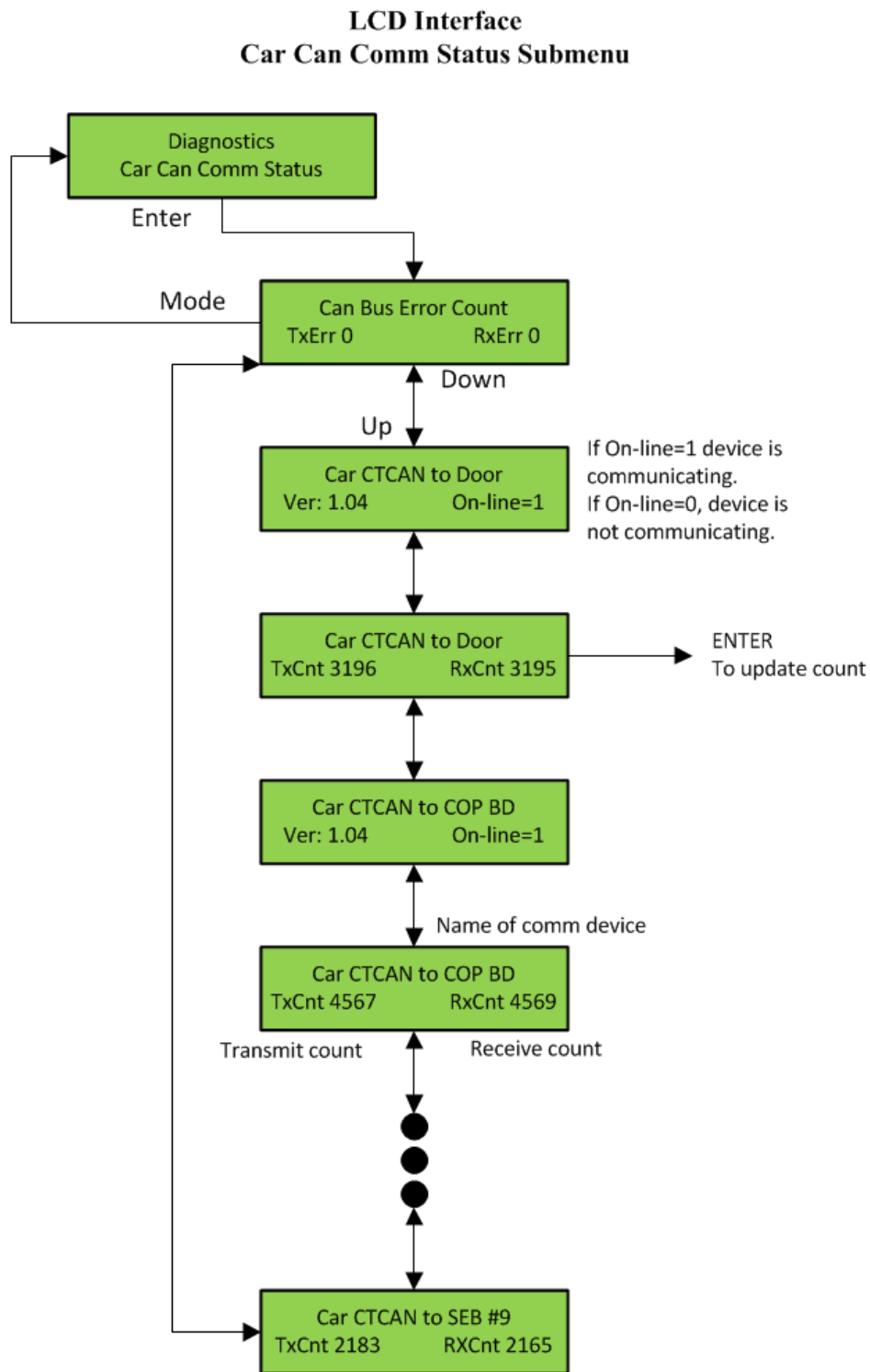

Figure 5-17: LCD Interface – Car Can Comm Status Submenu

5.2.18 Machine Room Can Comm Status

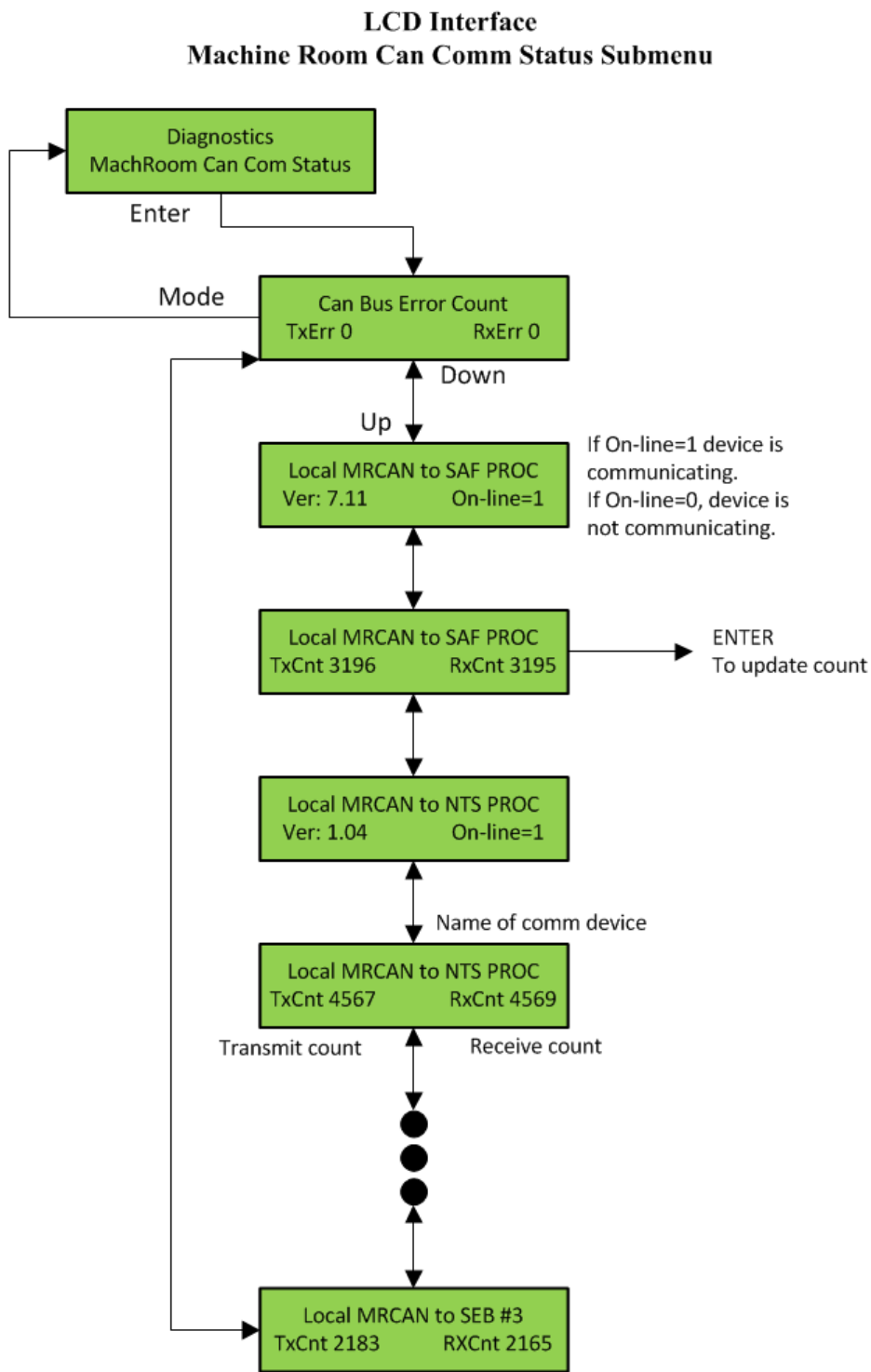
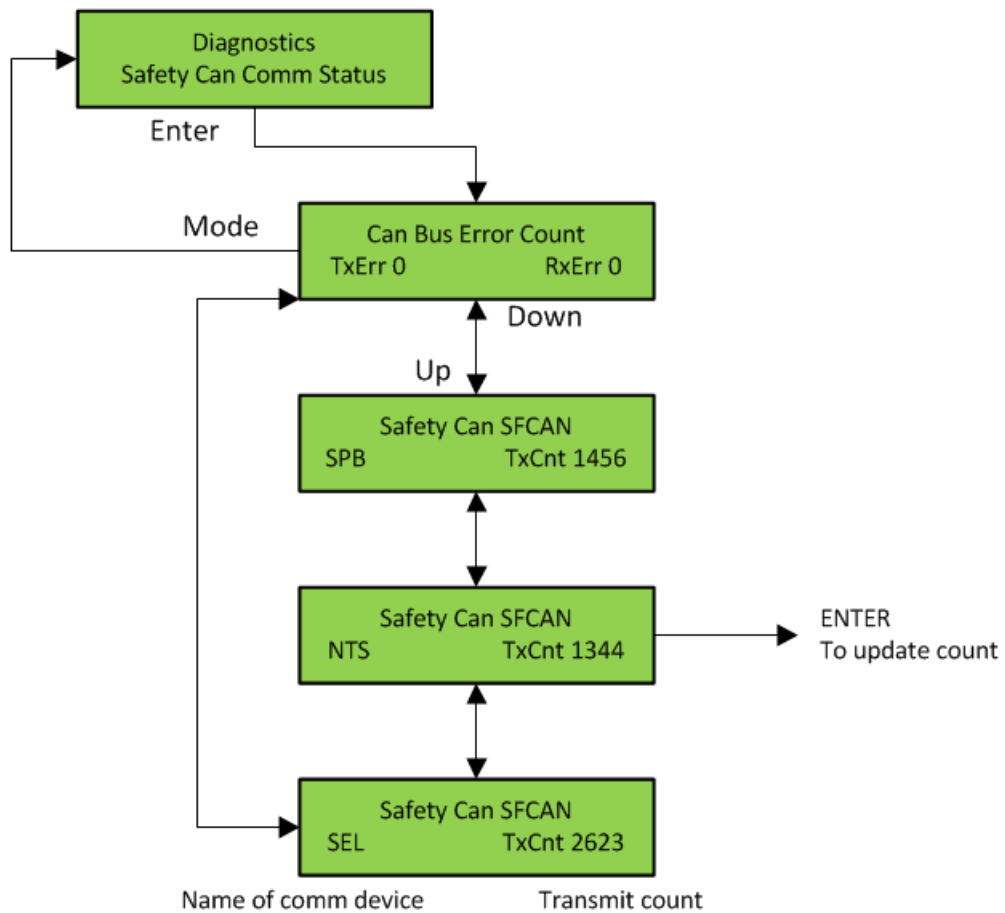

Figure 5-18: LCD Interface – Machine Room Can Comm Status Submenu

5.2.19 Safety Can Comm Status

**LCD Interface  
Safety Can Comm Status Submenu**



**Figure 5-19: LCD Interface – Safety Can Comm Status Submenu**

5.2.20 Drive Comm Status

**LCD Interface  
Drive Comm Status Submenu**

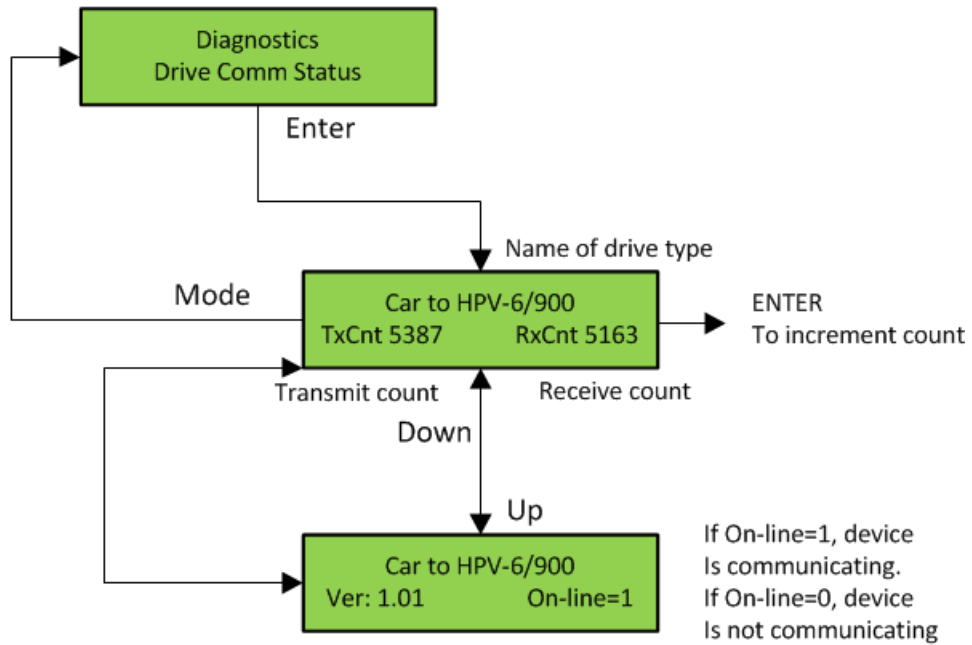

Figure 5-20: LCD Interface – Drive Comm Status Submenu

5.2.21 APS CAN Comm Status

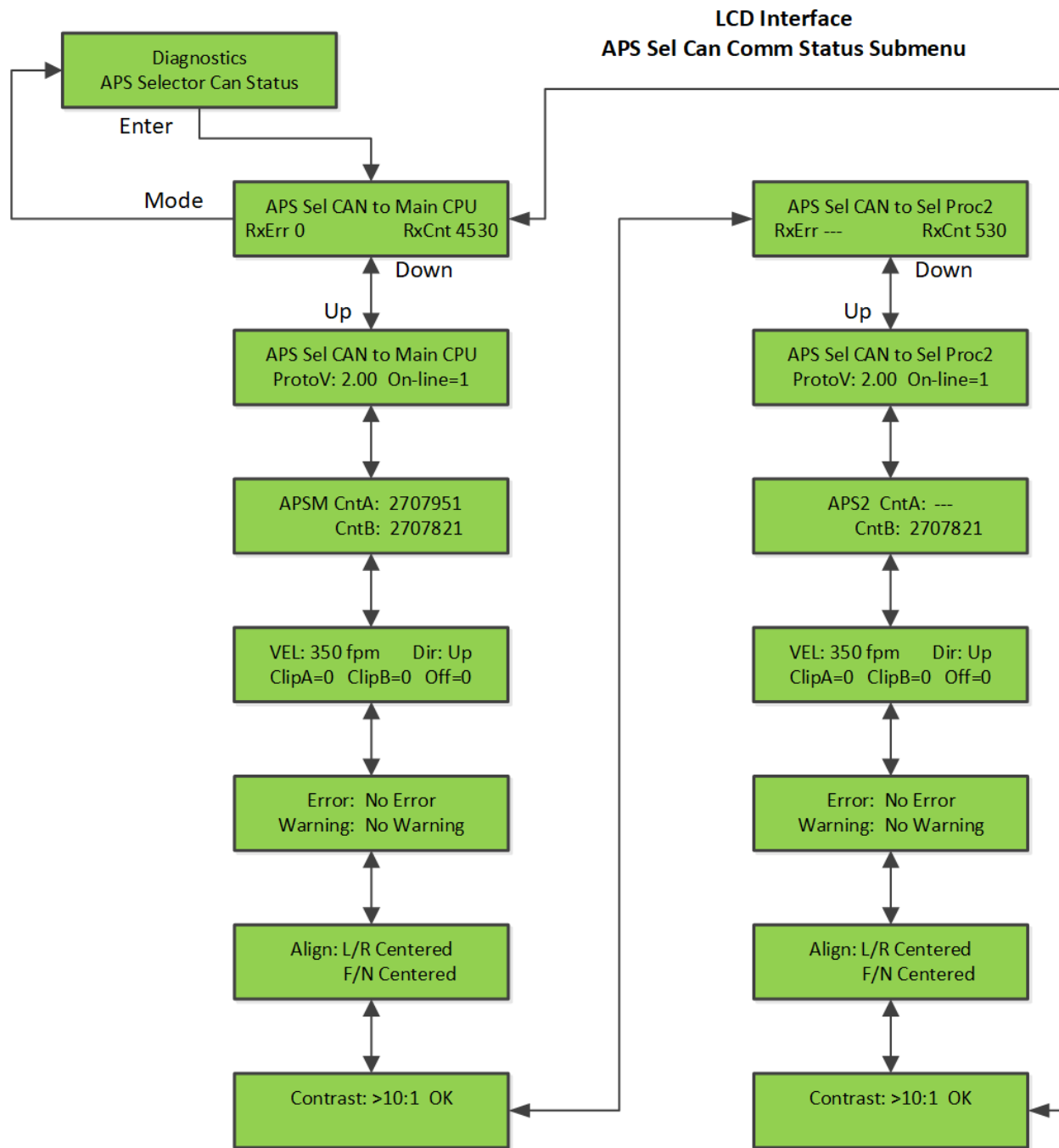

Figure 5-21: LCD Interface – APS Sel. Can. Comm. Status Submenu

5.2.22 Software Utilities

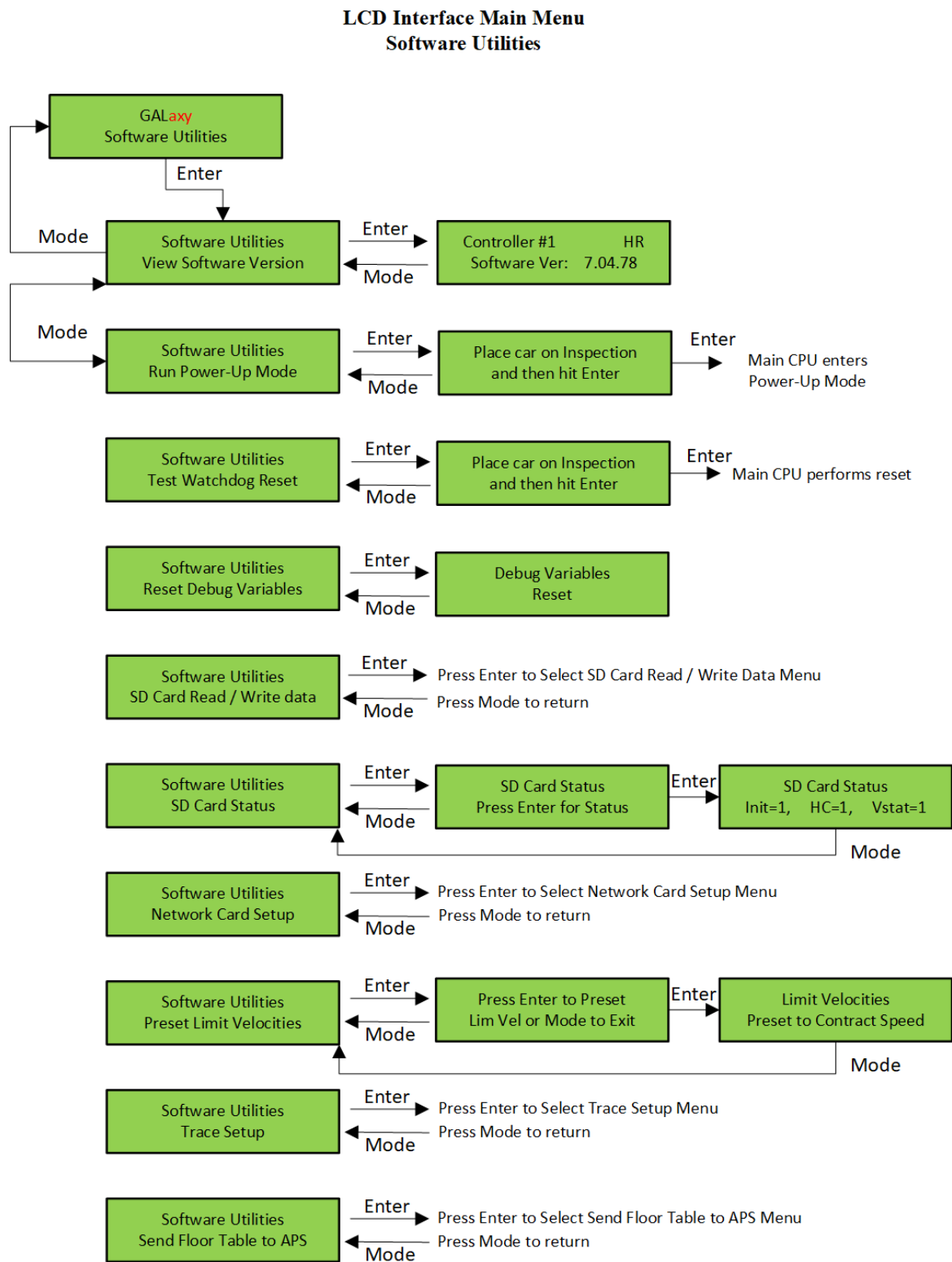

Figure 5-22: LCD Interface Main Menu – Software Utilities

5.2.23 Power-Up Mode

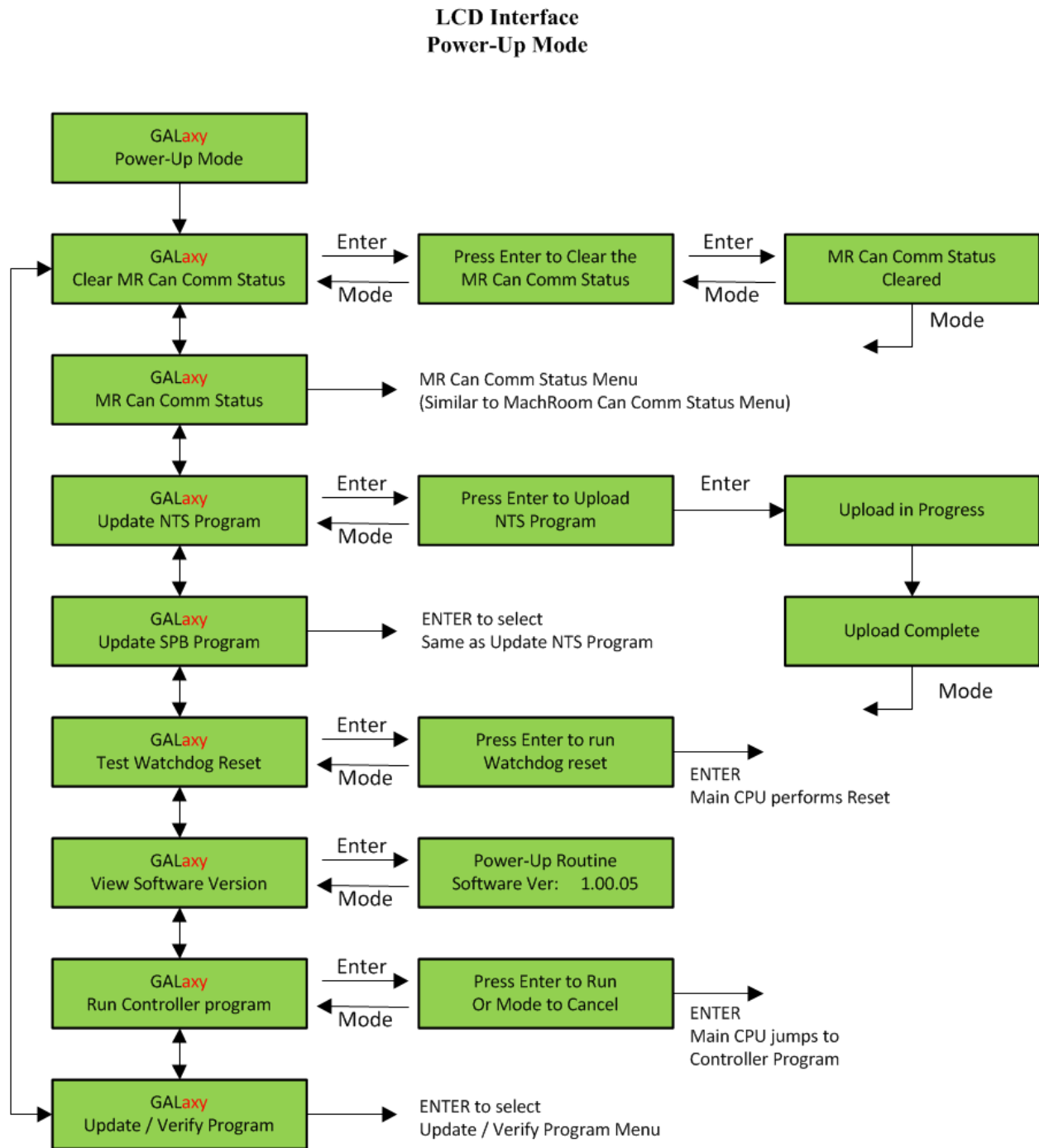

Figure 5-23: LCD Interface – Power-Up Mode

5.2.24 Power-Up Mode → Update / Verify Program

**LCD Interface  
Update / Verify Program Submenu**

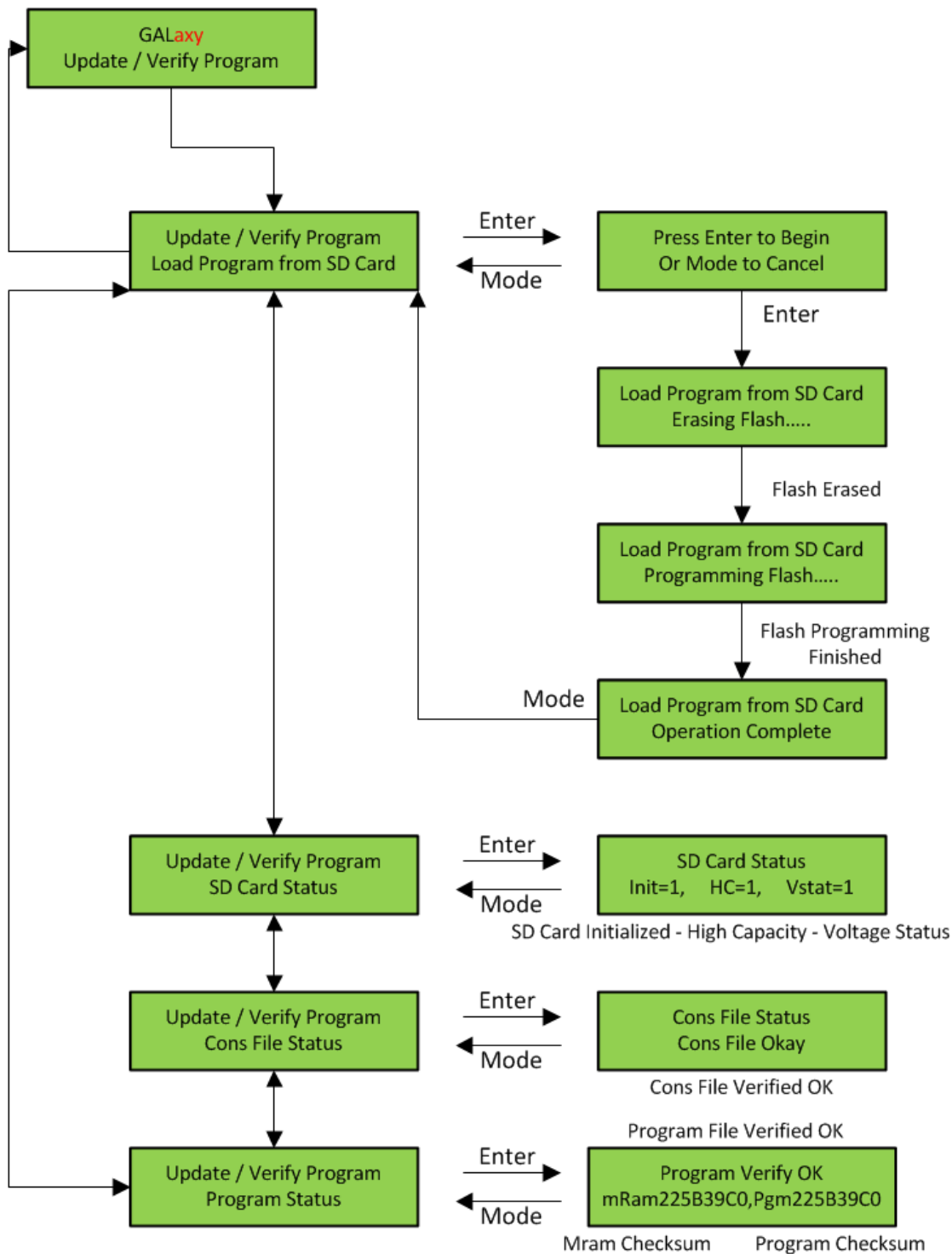
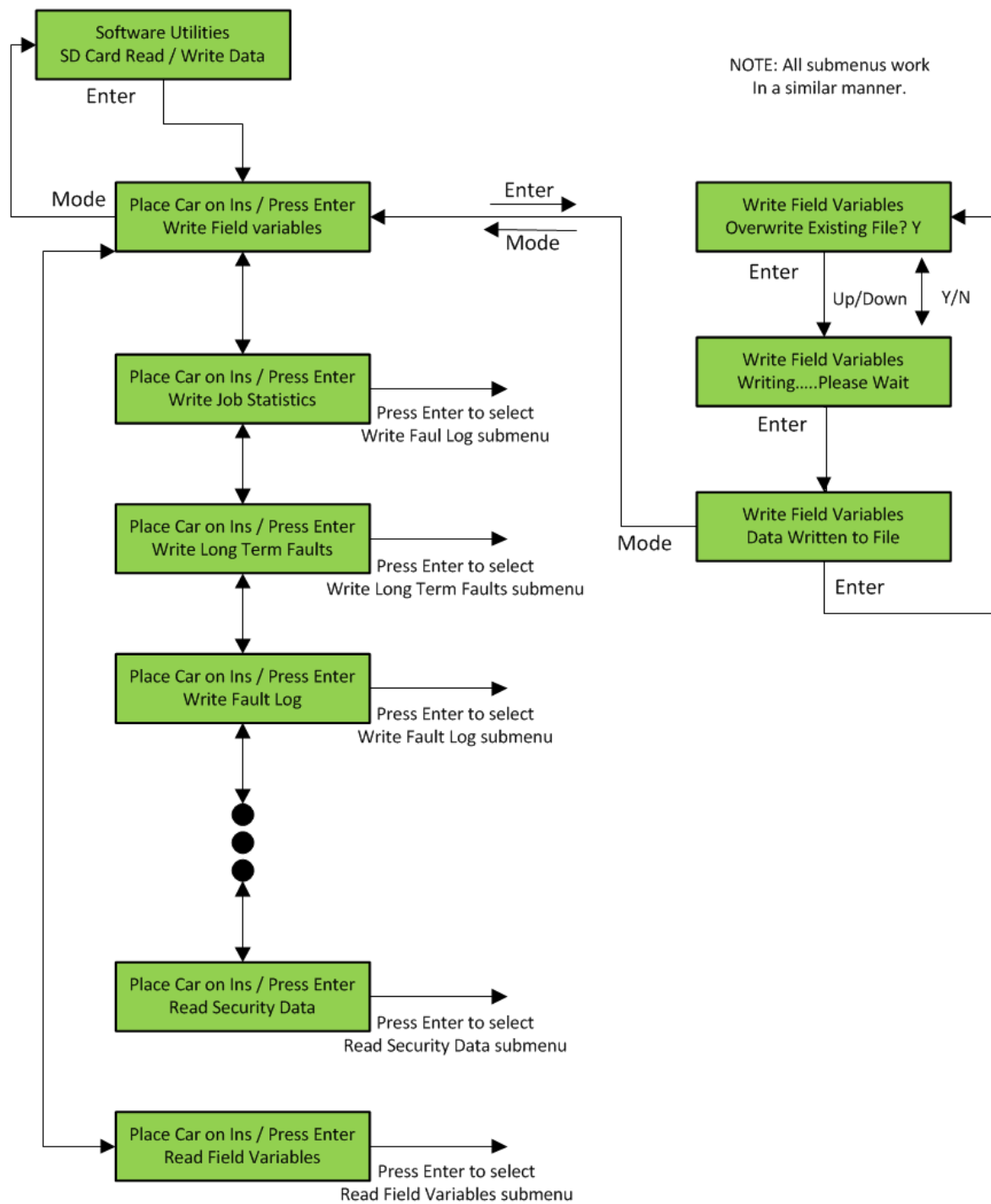

Figure 5-2423: LCD Interface – Update / Verify Program Submenu



5.2.25 SD Card Read / Write Data

**LCD Interface  
SD Card Read / Write Data Submenu**



NOTE: All submenus work In a similar manner.

Figure 5-25: LCD Interface – SD Card Read / Write Data Submenu

5.2.26 Network Card Setup

---

**LCD Interface  
Network Card Setup**

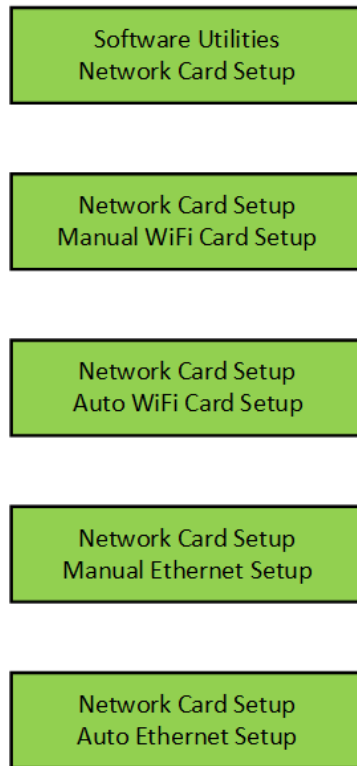
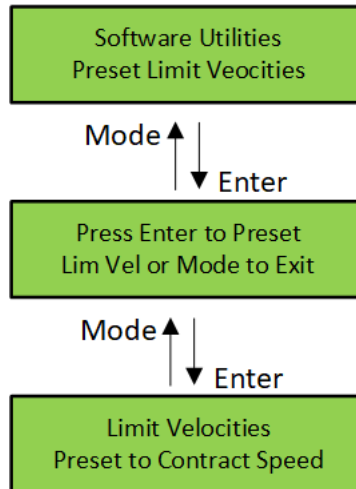

**Figure 5-26: LCD Interface Main Menu – Network card Setup**

5.2.27 Preset Limit Velocities

---

**LCD Interface  
Preset Limit Velocities**



**Figure 5-27: LCD Interface Main Menu – Preset Limit Velocities**

5.2.28 Trace Setup

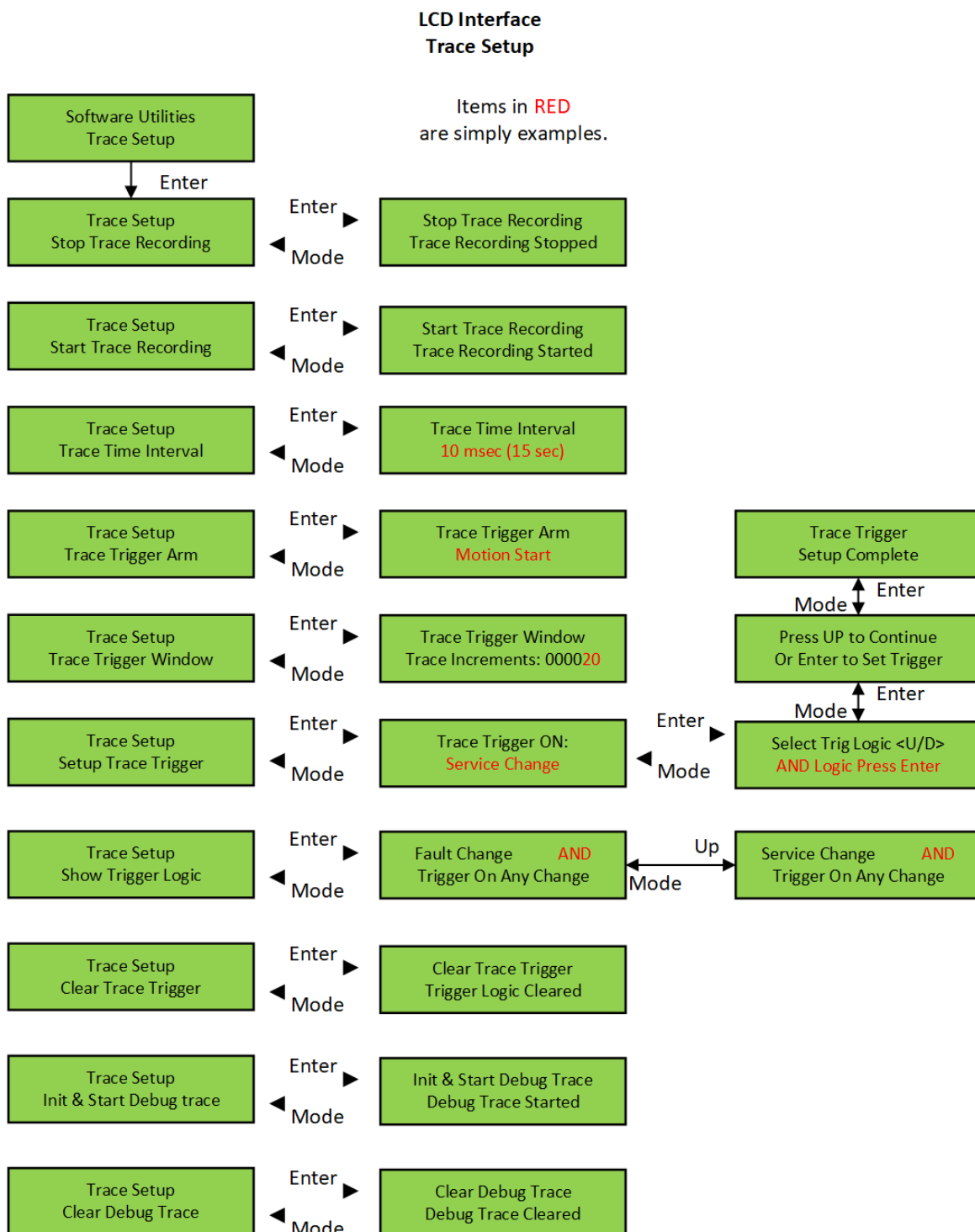

Figure 5-28: LCD Interface Main Menu – Trace Setup

5.2.29 Send Floor Table to APS

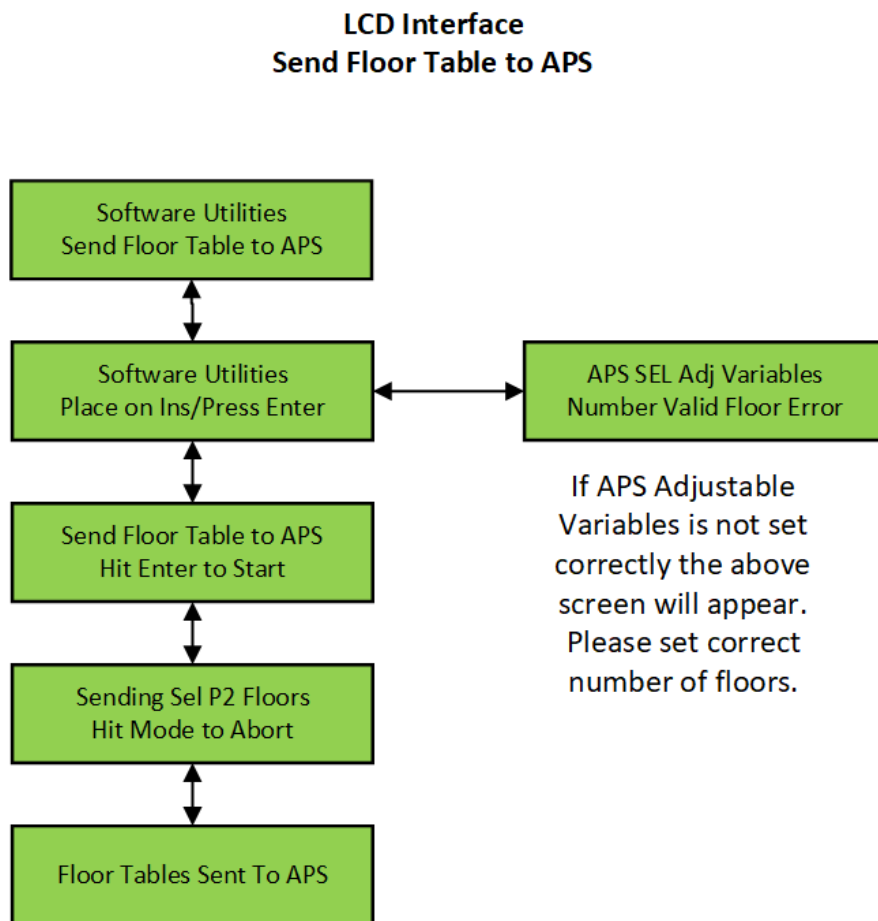

Figure 5-29: LCD Interface – Send Floor Table to APS

5.2.30 Select Video Display

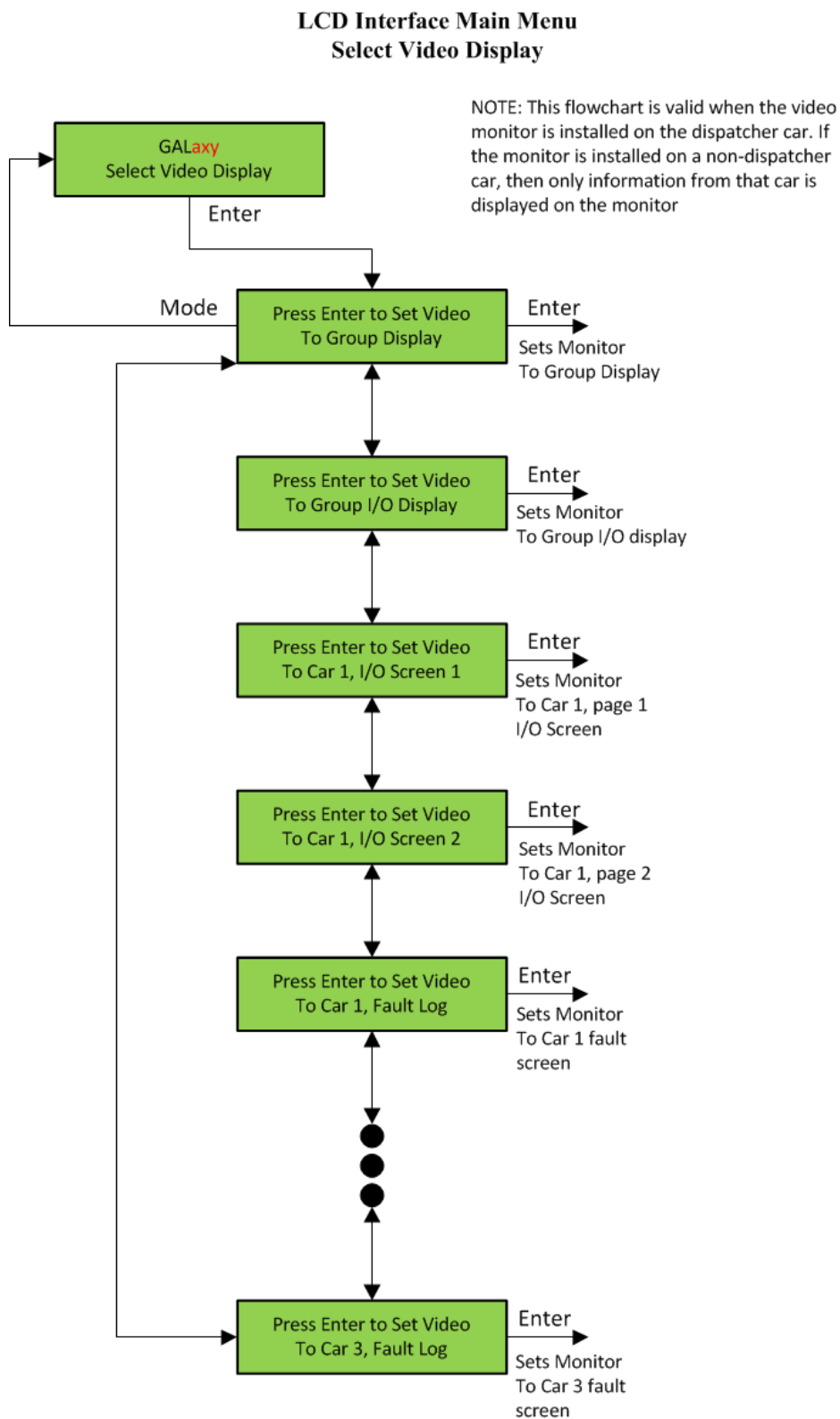

Figure 5-30: LCD Interface Main Menu – Select Video Display

5.2.31 Service Activation Timer

### LCD Interface Main Menu Service Activation Timer

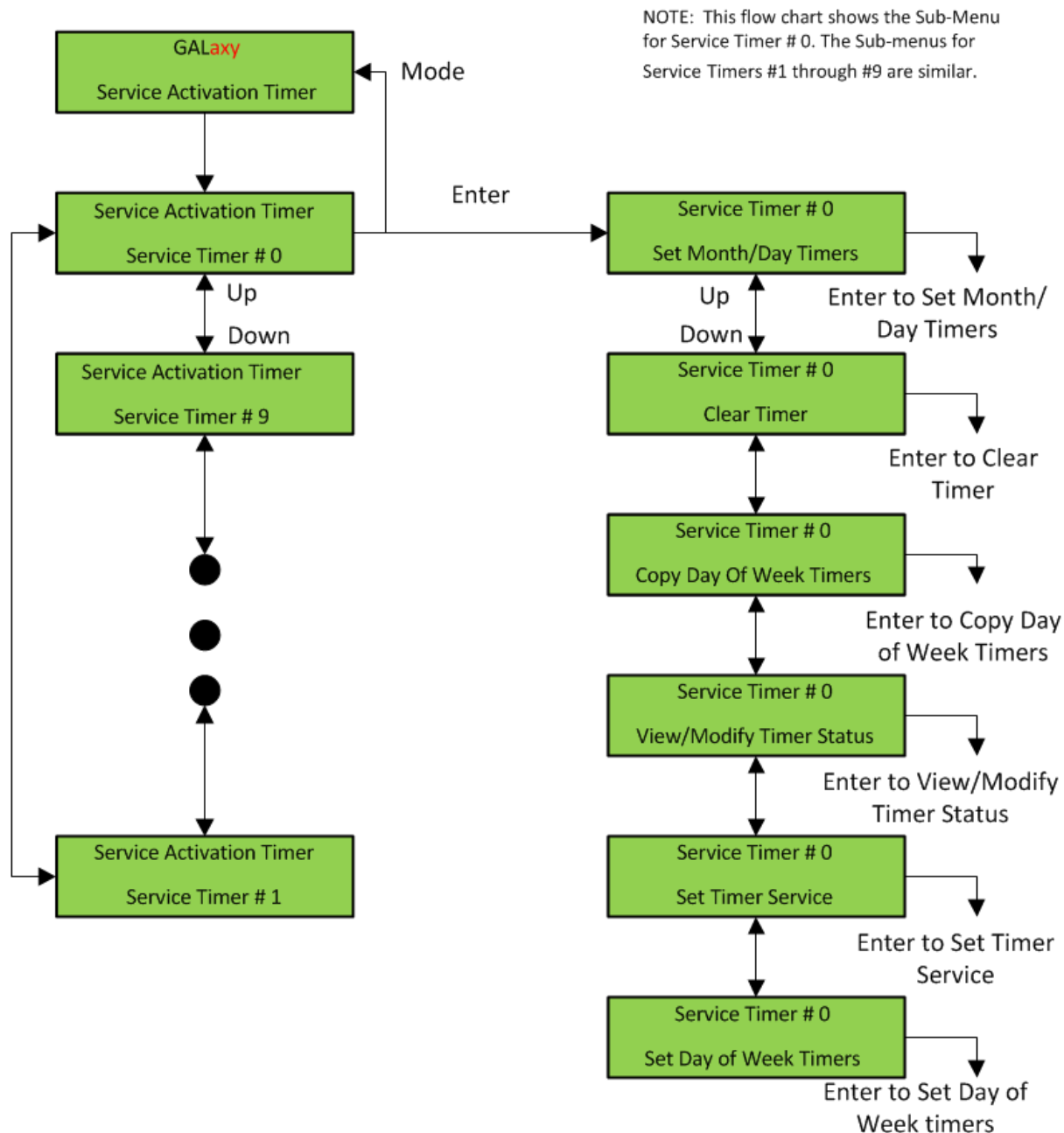

Figure 5-31: LCD Interface Main Menu – Service Activation Timer

5.2.32 Set Month/Day Timers

**LCD Interface**  
**Service Activation Timer Sub-menu**  
**Set Month/Day Timers**

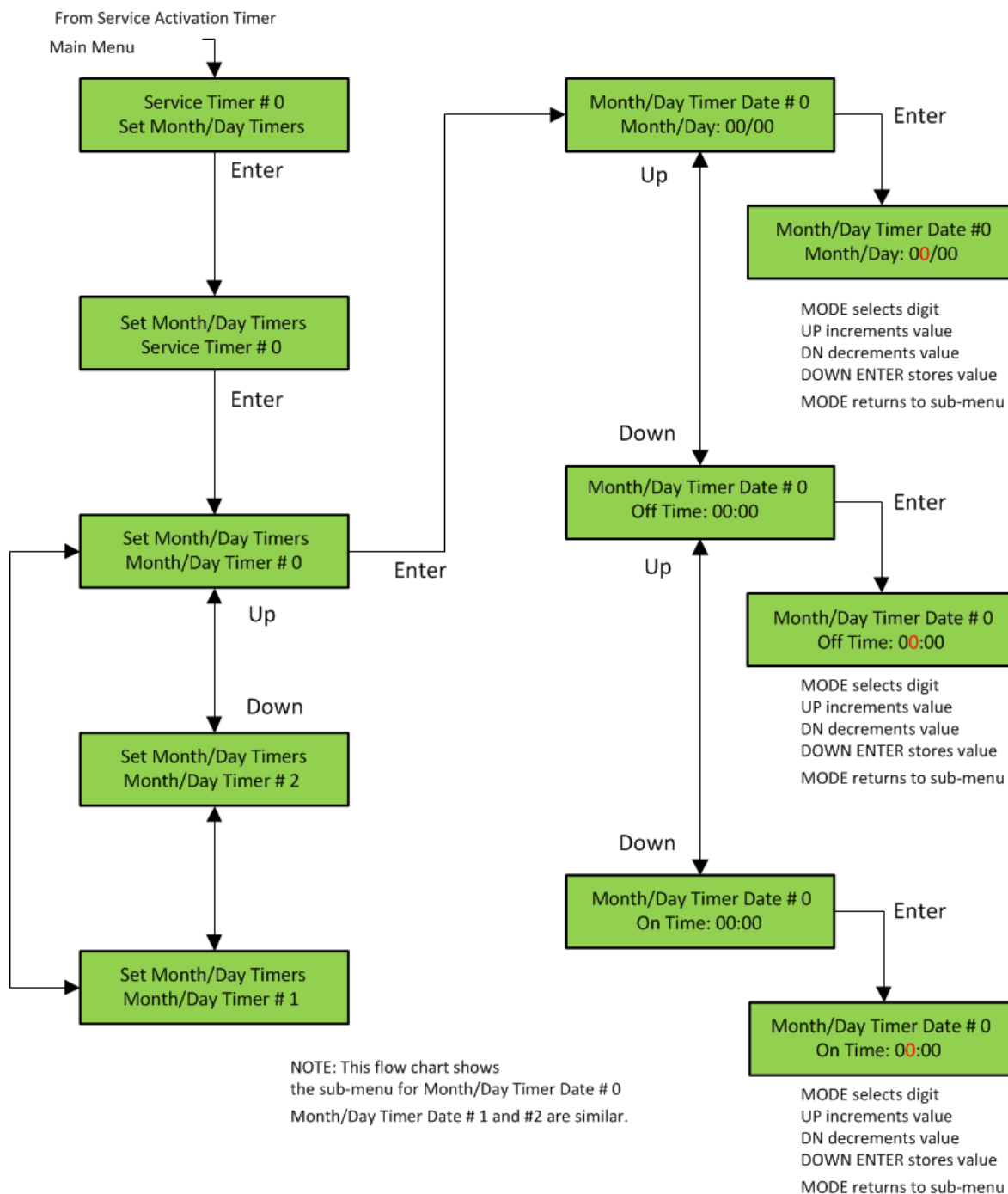

Figure 5-32: Service Activation Timer Submenu – Set Month/Day Timers



5.2.33 Clear Timers

**LCD Interface  
Service Activation Timer Sub-menu  
Clear Timer**

From Service Activation Timer  
Main Menu

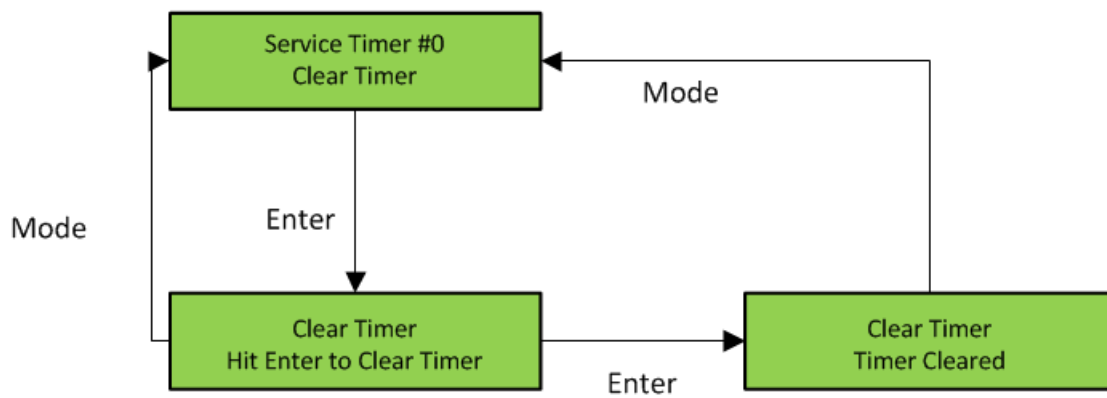

**Figure 5-33: Service Activation Timer Submenu – Clear Timers**

5.2.34 Copy Day of Week Timers

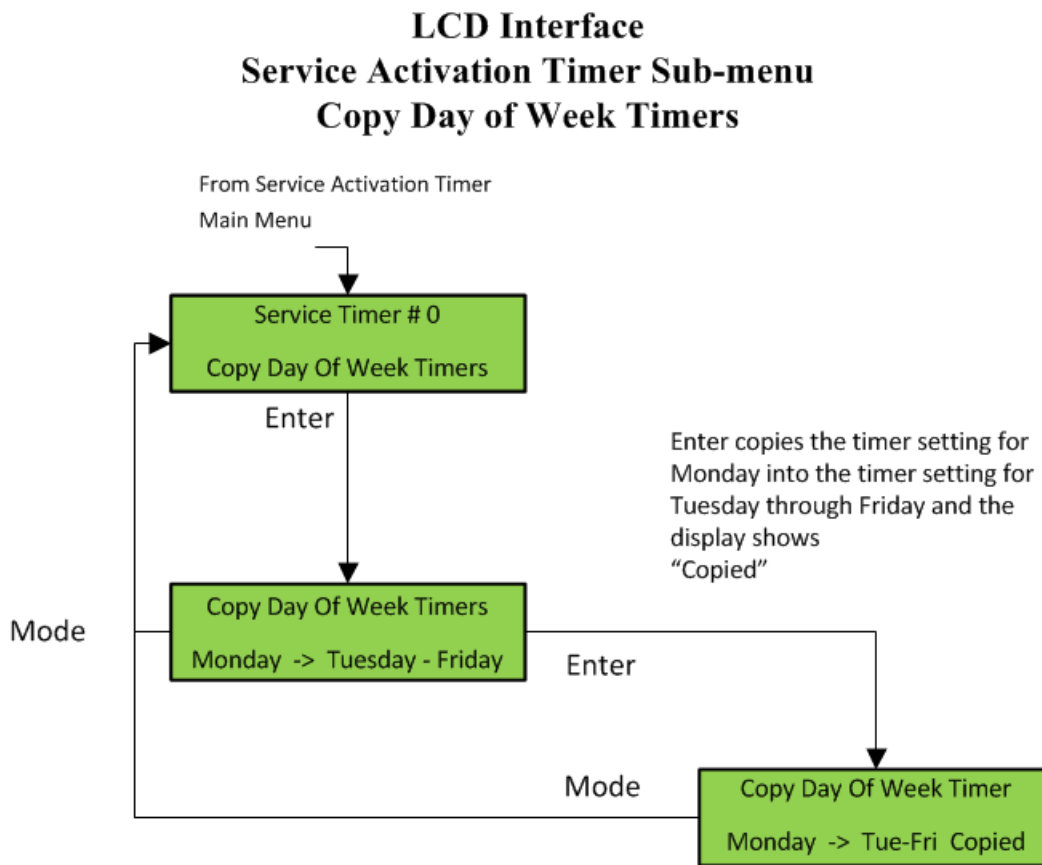

Figure 5-34: Service Activation Timer Submenu – Copy Day-of-Week Timers

5.2.35 View / Modify Timer Status

**LCD Interface**  
**Service Activation Timer Sub-menu**  
**View/Modify Timer Status**

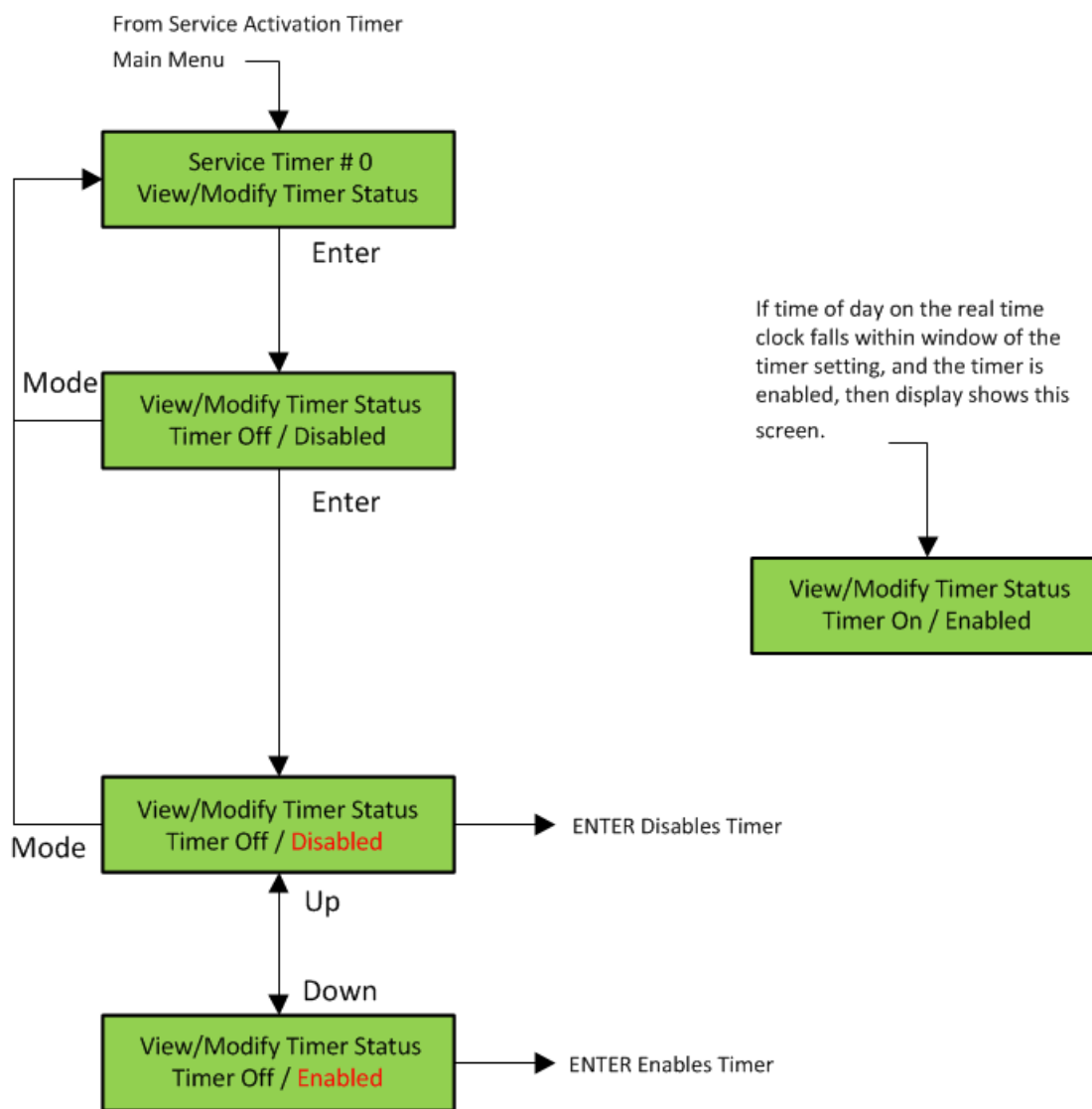

Figure 5-35: Service Activation Timer Submenu – View / Modify Timer Status

5.2.36 Set Timer Service

**LCD Interface**  
**Service Activation Timer Sub-menu**  
**Set Timer Service**

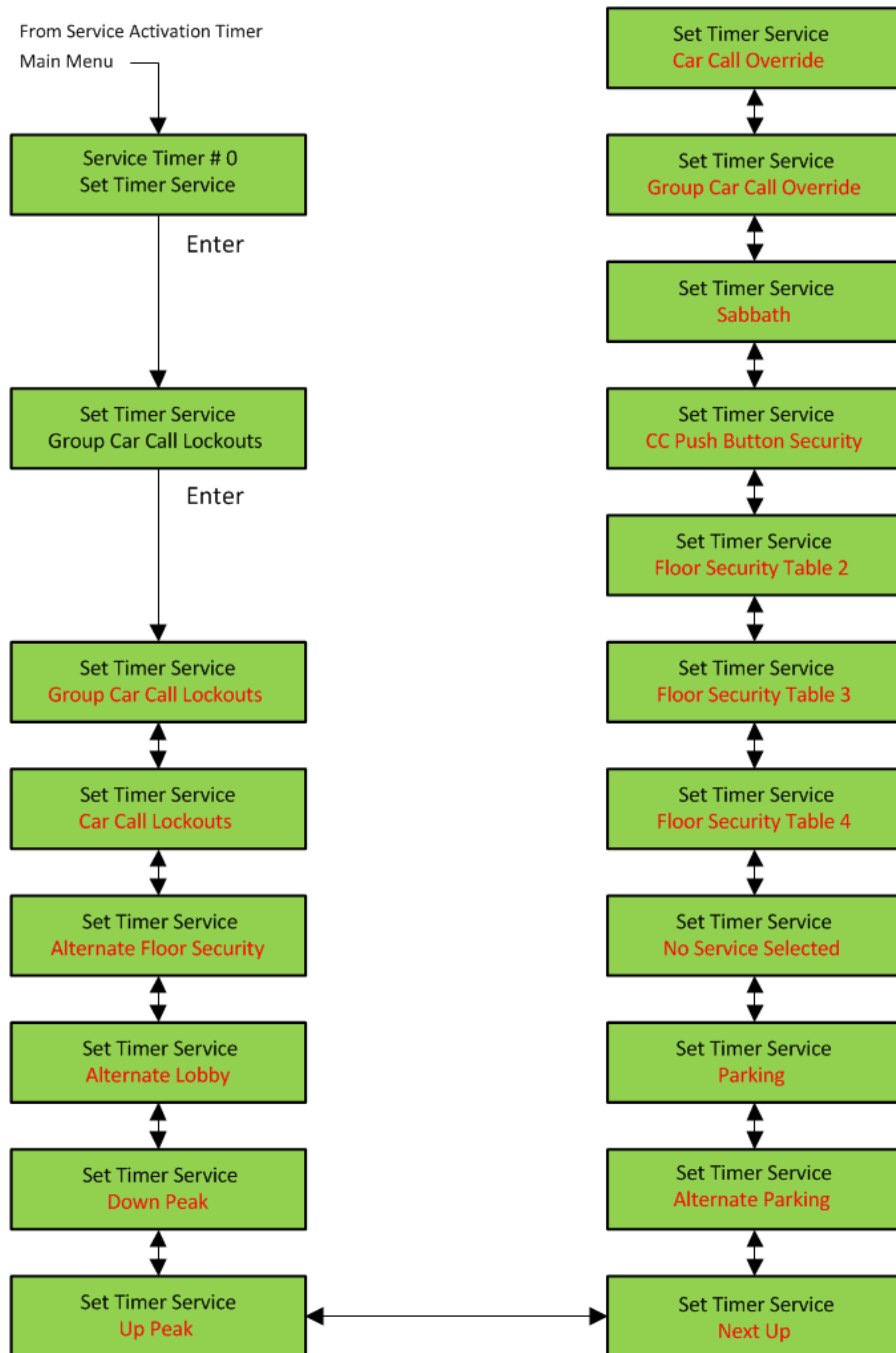

Figure 5-36: Service Activation Timer Submenu – Set Timer Service

5.2.37 Set Day of Week Timers

**LCD Interface**  
**Service Activation Timer Sub-menu**  
**Set Day of Week Timers**

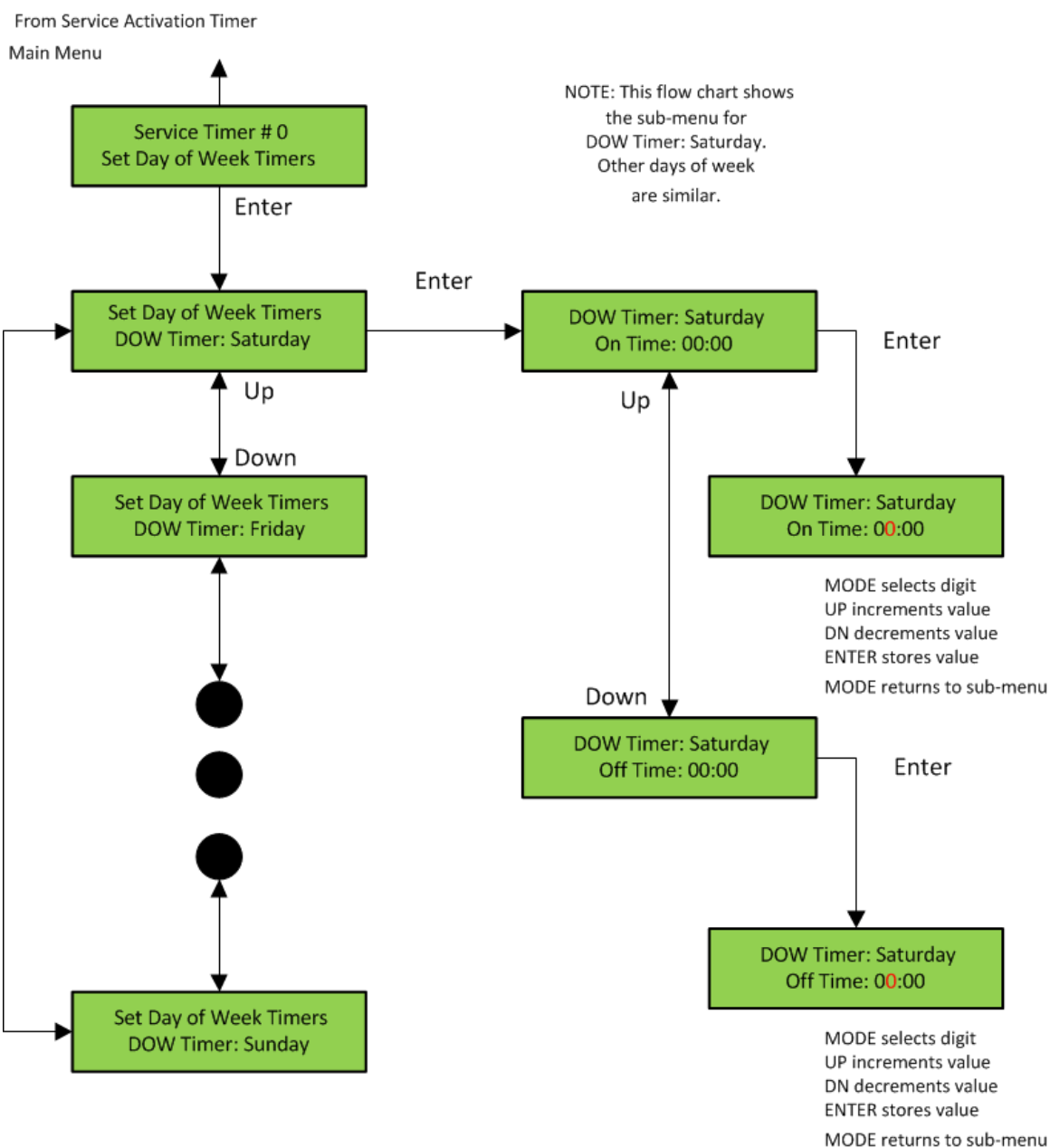

Figure 5-37: Service Activation Timer Submenu – Set Day-of-Week Timers

5.2.38 Display/Modify Hoistway Tables

**LCD Interface Main Menu**  
**Hoistway Tables**  
**Disp / Mod Hoistway Tables Submenu**

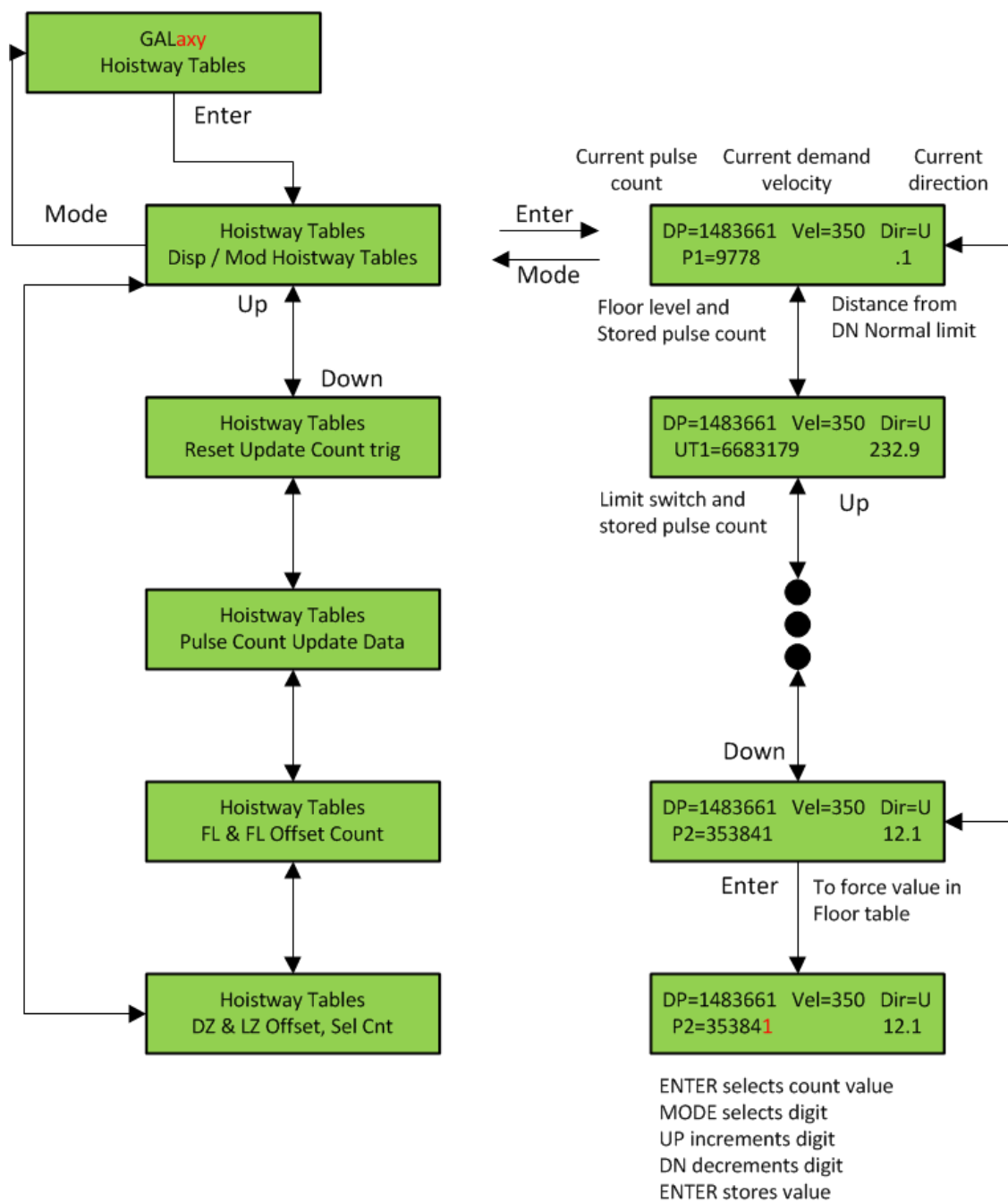

Figure 5-24: Hoistway Tables – Disp. / Mod. Hoistway Tables Submenu

5.2.39 DZ & DZ Offset, Selector Count

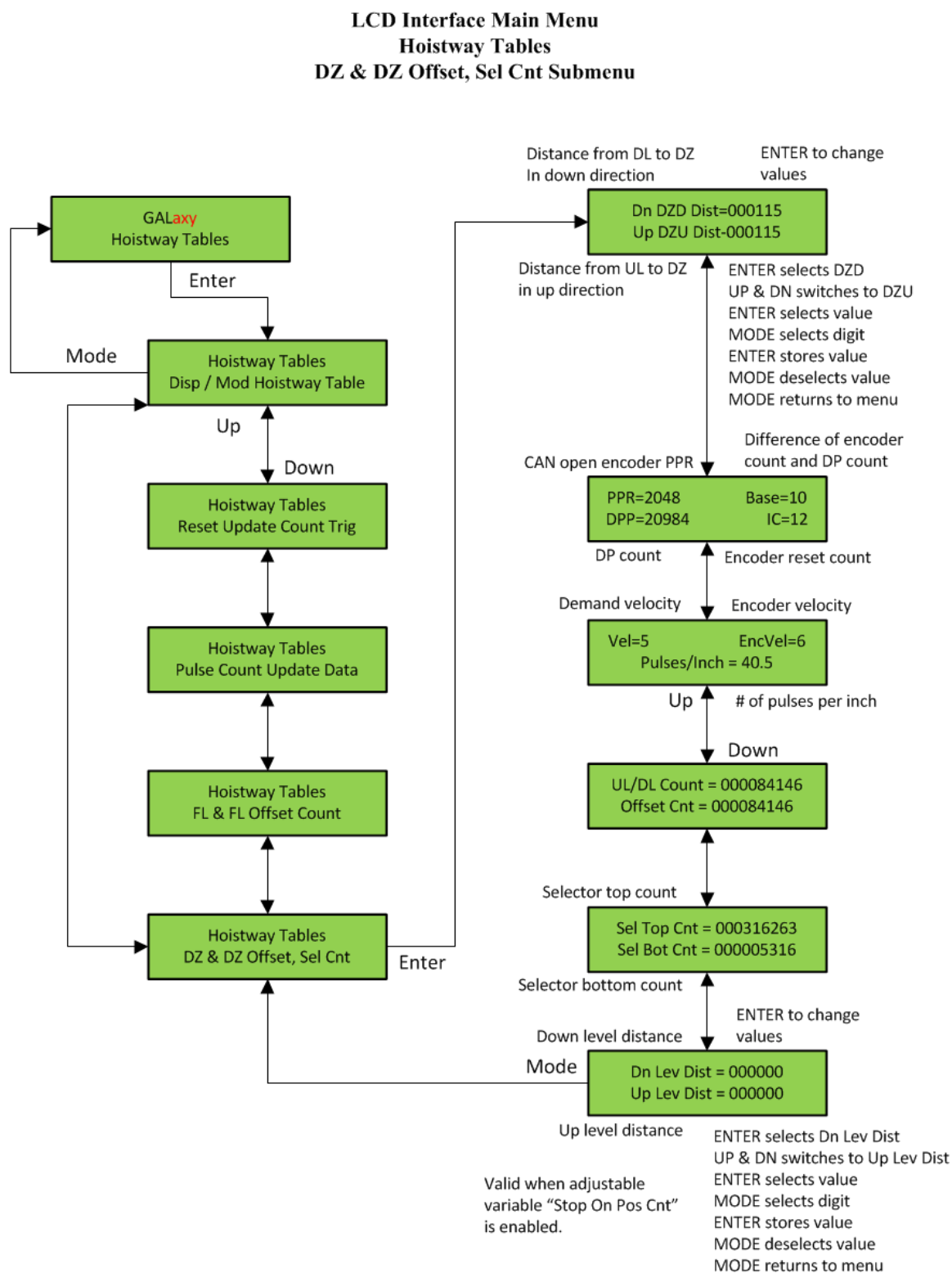

Figure 5-39: Hoistway Tables – DZ & DZ Offset, Sel. Cnt. Submenu

5.2.40 FL & FL Offset Count

**LCD Interface Main Menu**  
**Hoistway Tables**  
**FL & FL Offset, Sel Cnt Submenu**

NOTE: The "Offset value below is valid when the "Stop On Pos Count" adjustable variable is enabled.

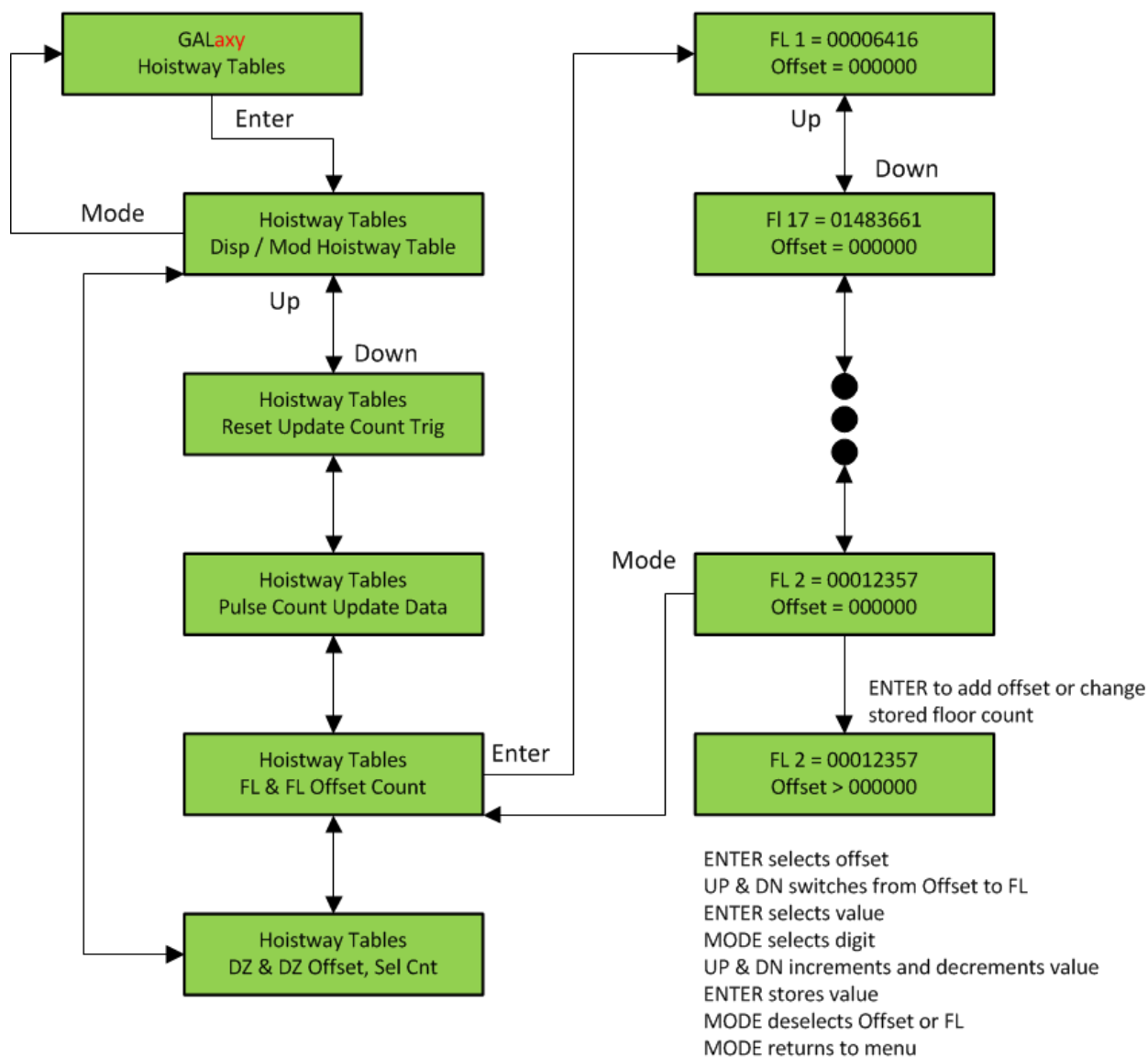

Figure 5-40: Hoistway Tables FL & FL Offset, Sel. Cnt. Submenu



5.2.41 Reset Update Count, Pulse Count Update

**LCD Interface Main Menu**  
**Hoistway Tables**  
**Reset Update Count Trig, Pulse Count Update Data Submenu**

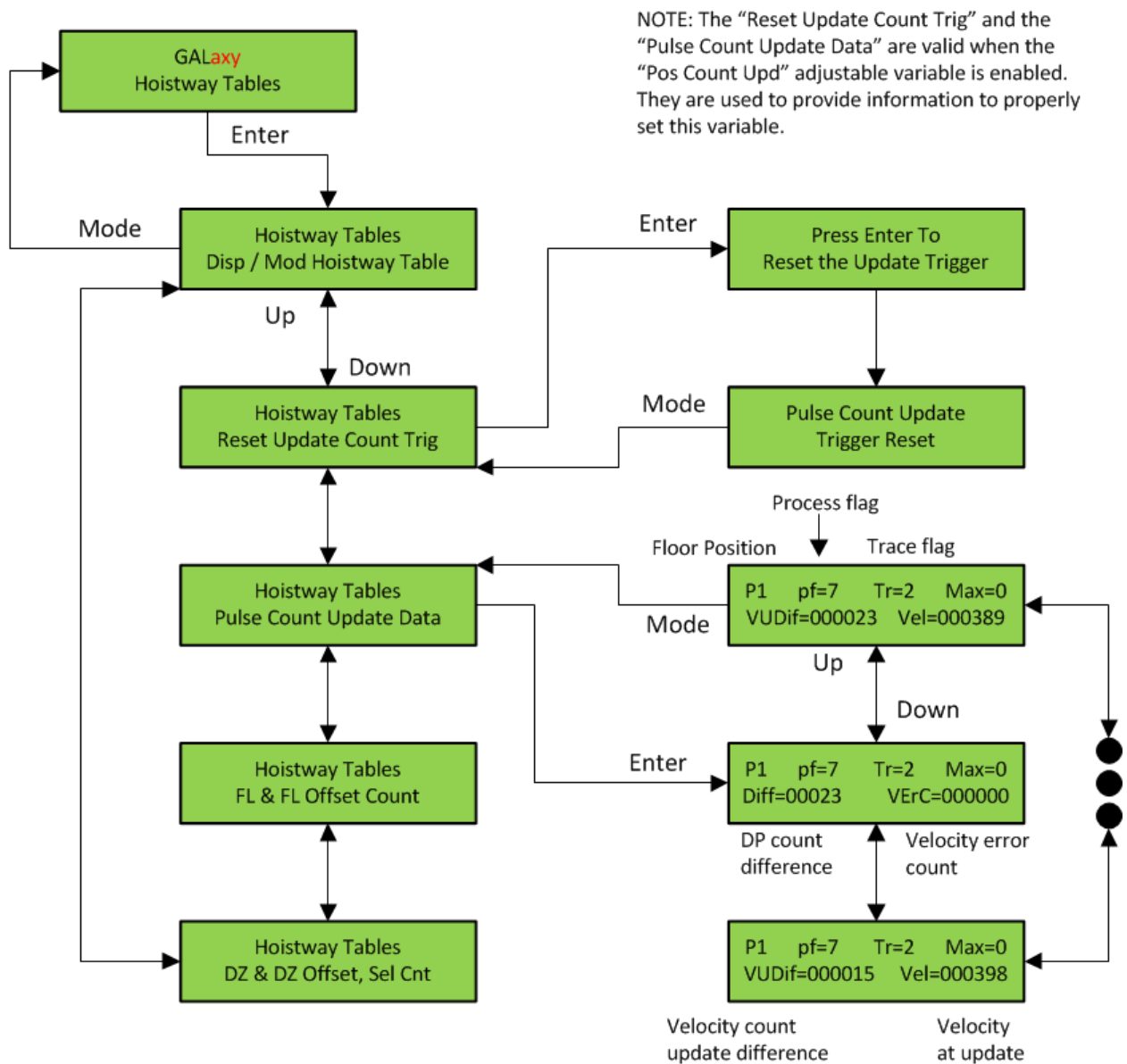

Figure 5-41: Hoistway Tables – Reset Update Count Trig. / Pulse Count Update Data Submenu

5.2.42 Elevator Setup

**LCD Interface Main Menu  
Elevator Setup**

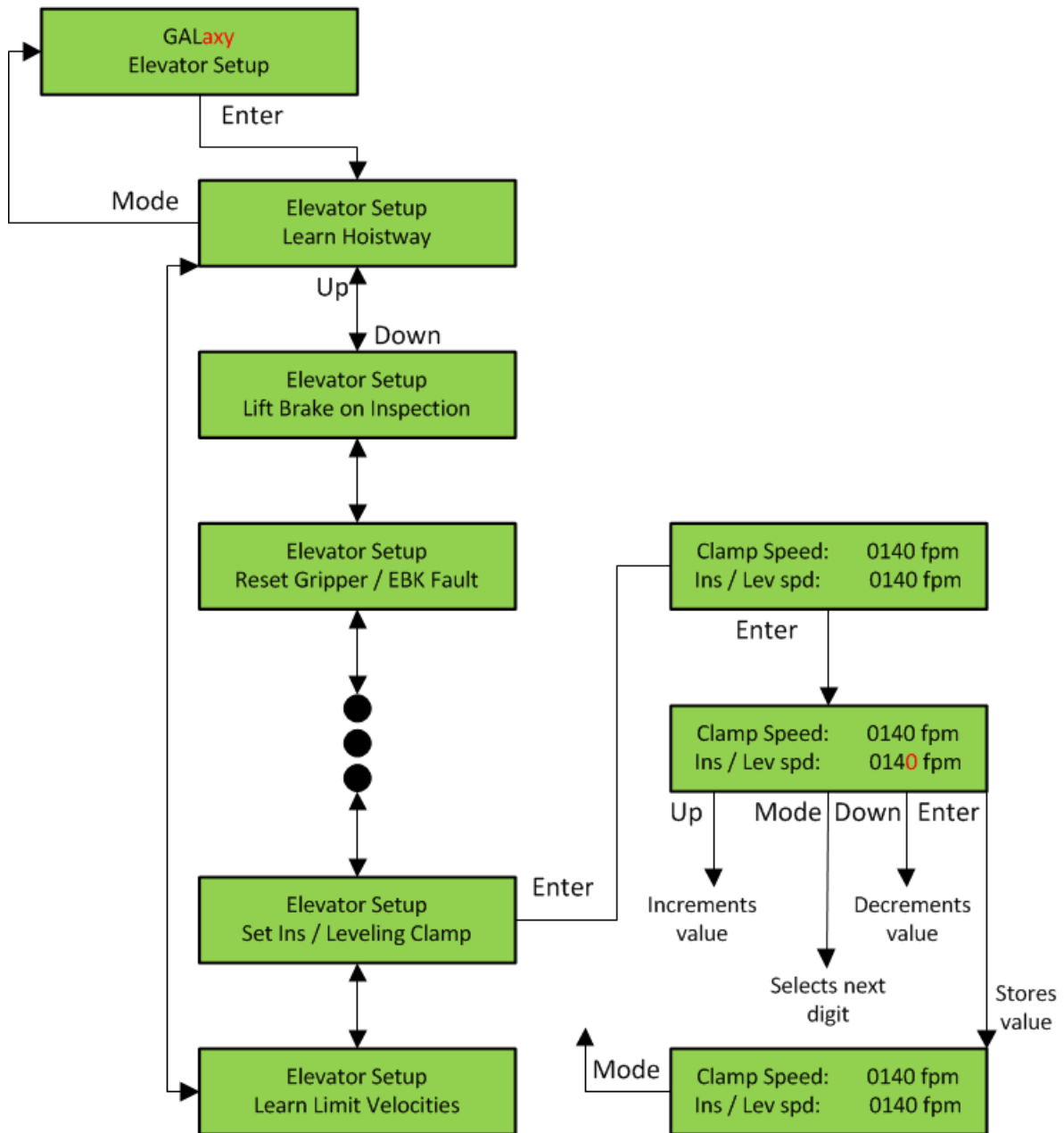

Figure 5-25: LCD Interface Main Menu – Elevator Setup

5.2.43 Match Feedback Velocity & Direction

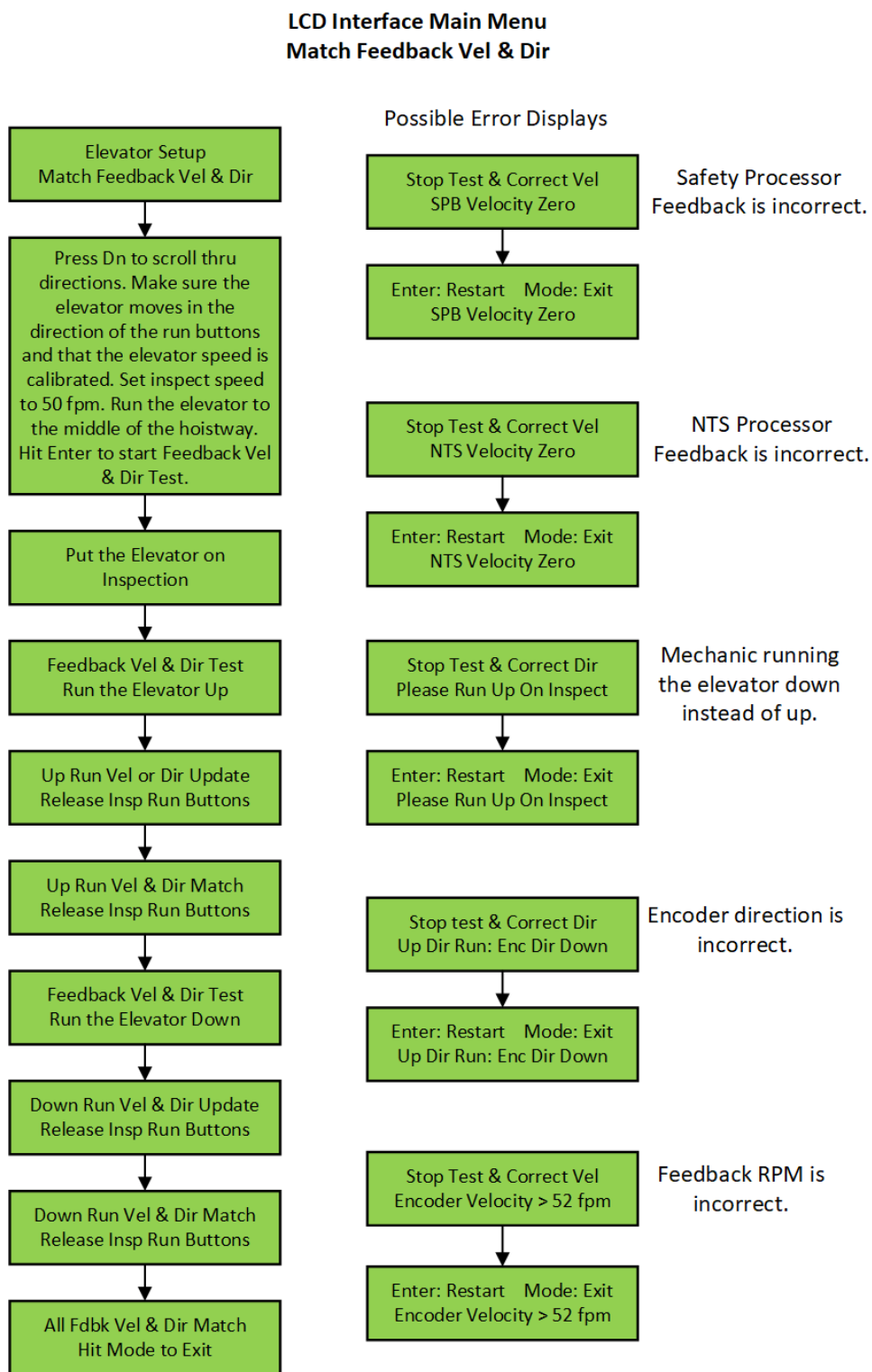

Figure 5-43: LCD Interface Main Menu – Match Feedback Velocity & Direction

5.2.44 Learn Hoistway

5.2.44.1 Learn Hoistway for Tapeless Selector

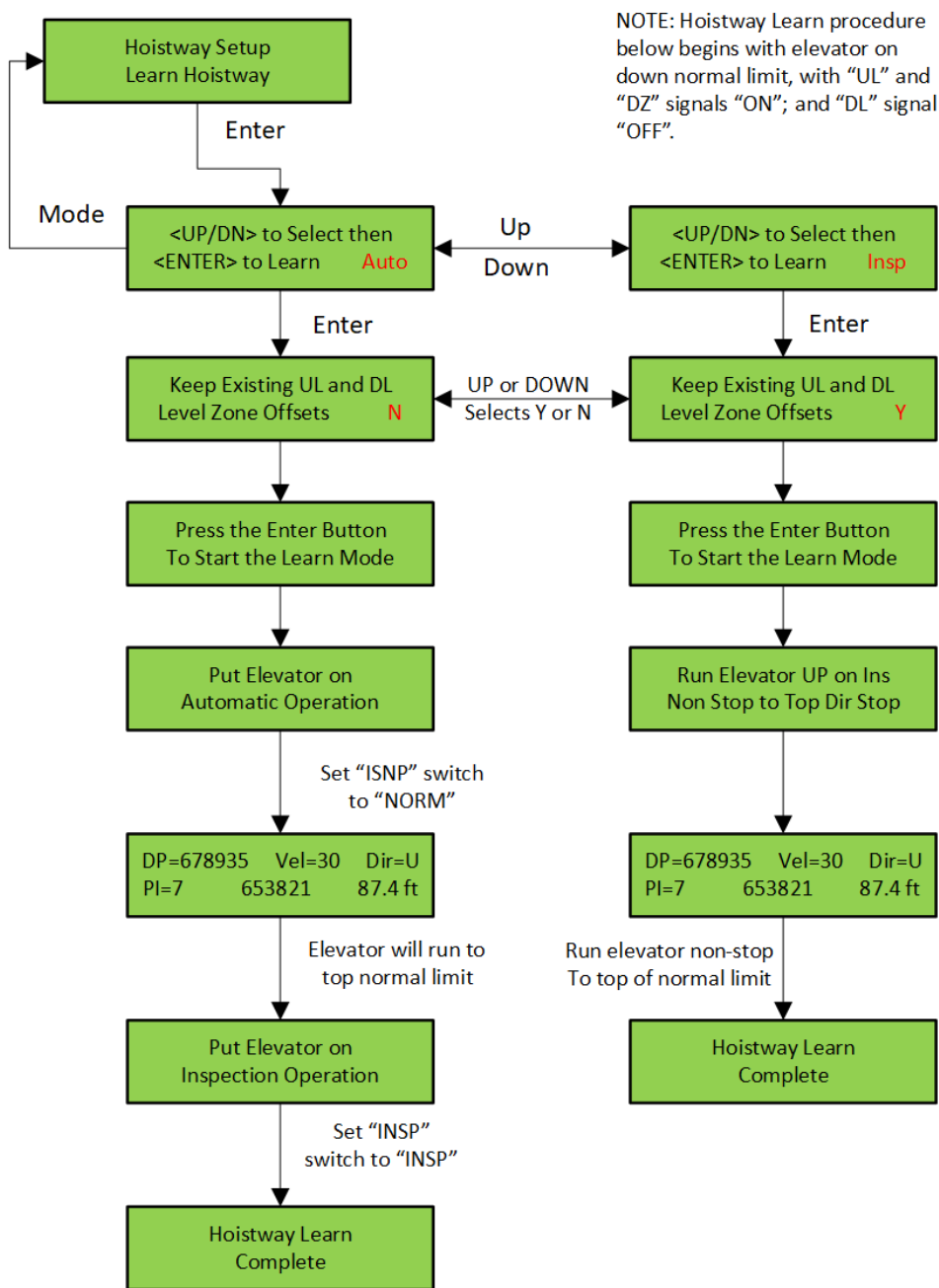

Figure 5-44: LCD Interface – Learn Hoistway Submenu for Tape & Tapeless Selectors

5.2.44.2 Learn Hoistway for APS Selector

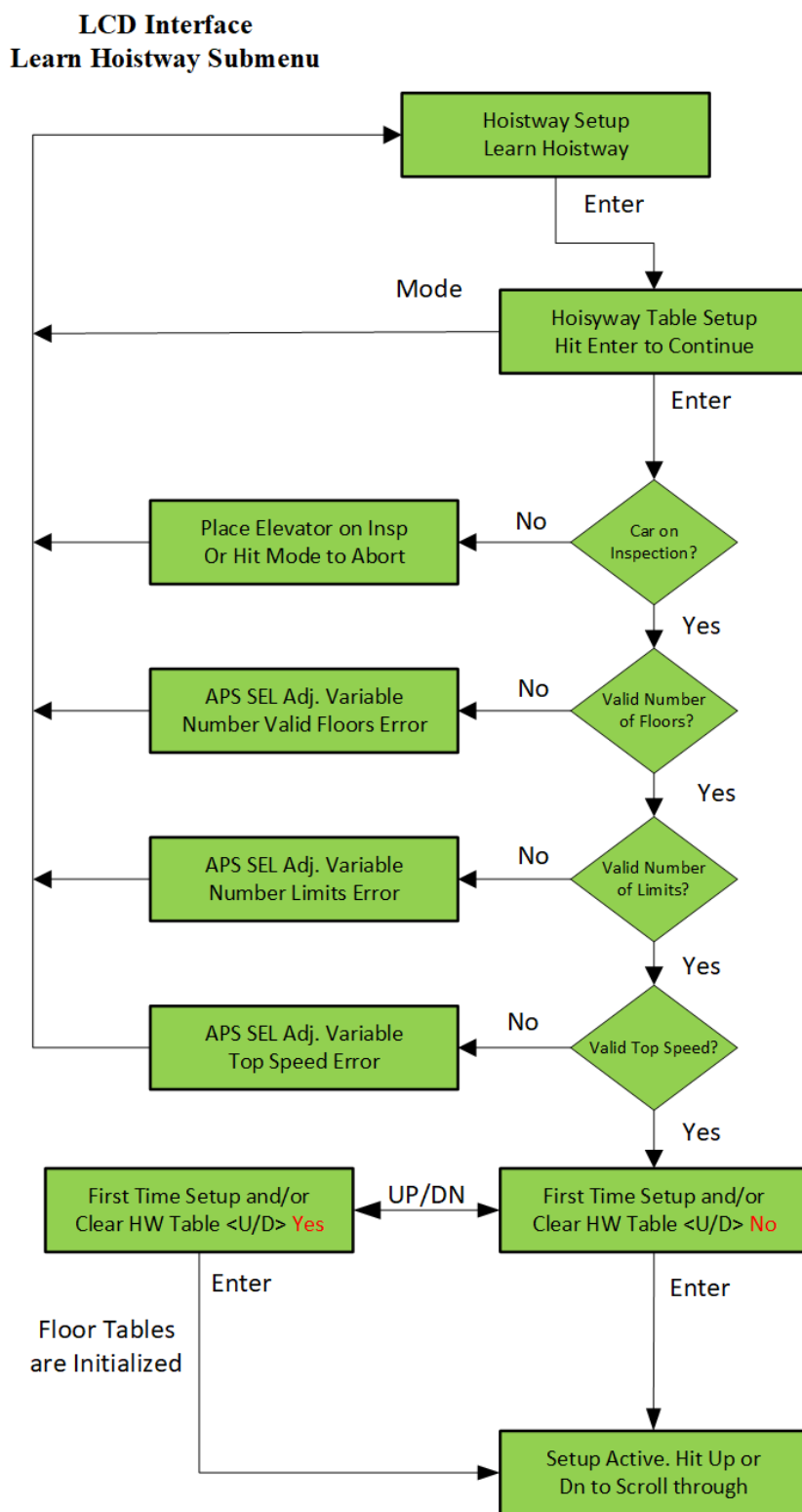

Figure 5-45: LCD Interface – Learn Hoistway Submenu for APS Selectors (Page i)

**LCD Interface  
Learn Hoistway Submenu  
(Continued)**

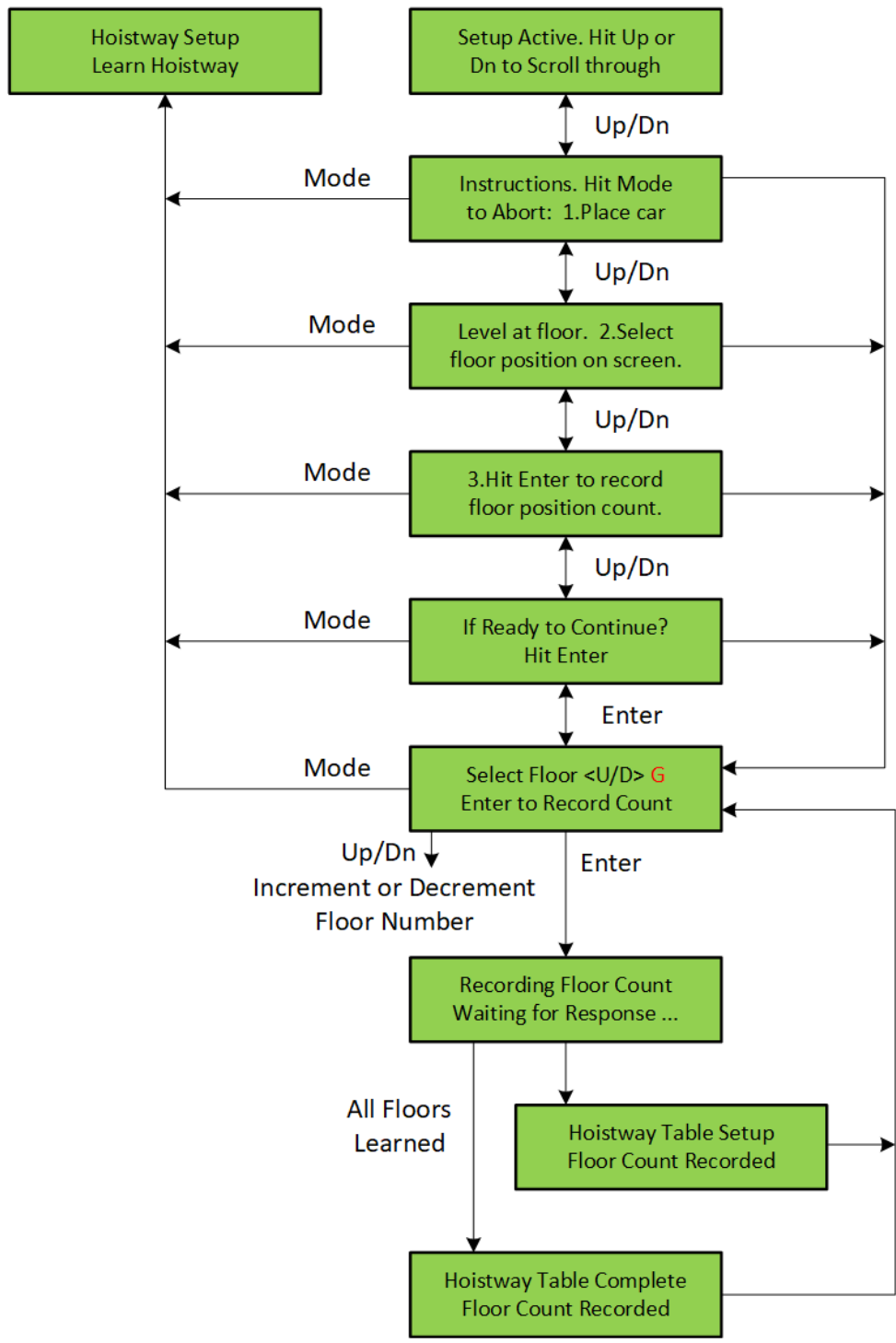

Figure 5-46: LCD Interface – Learn Hoistway Submenu for APS Selectors (Page ii)

5.2.45 Learn Limit Velocities

**LCD Interface  
Learn Limit Velocities Submenu**

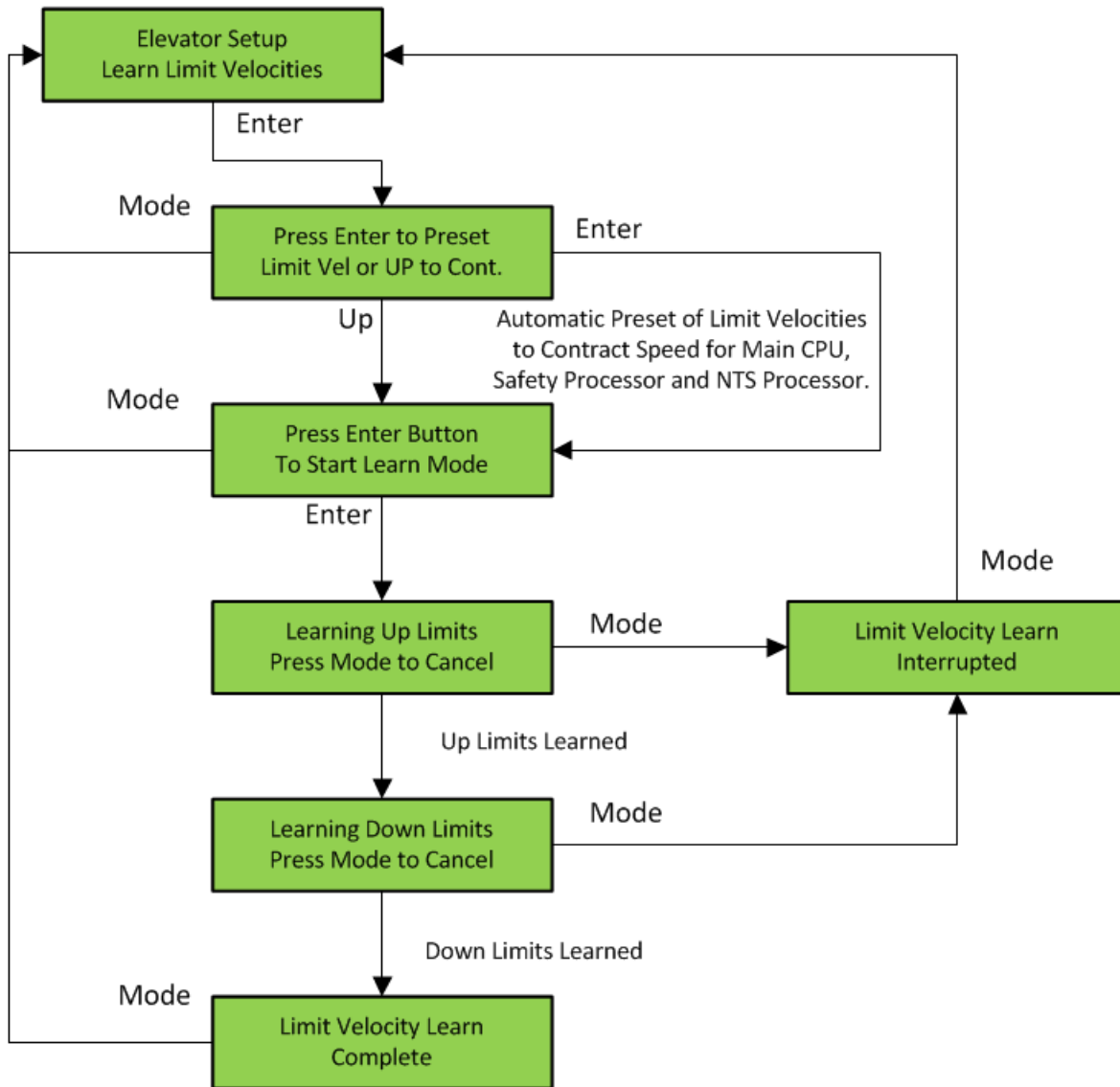

Figure 5-4726: LCD Interface – Learn Limit Velocities Submenu

5.2.46 Open / Close Door

**LCD Interface**  
**Open / Close Front Door**  
**Open / Close Rear Door**

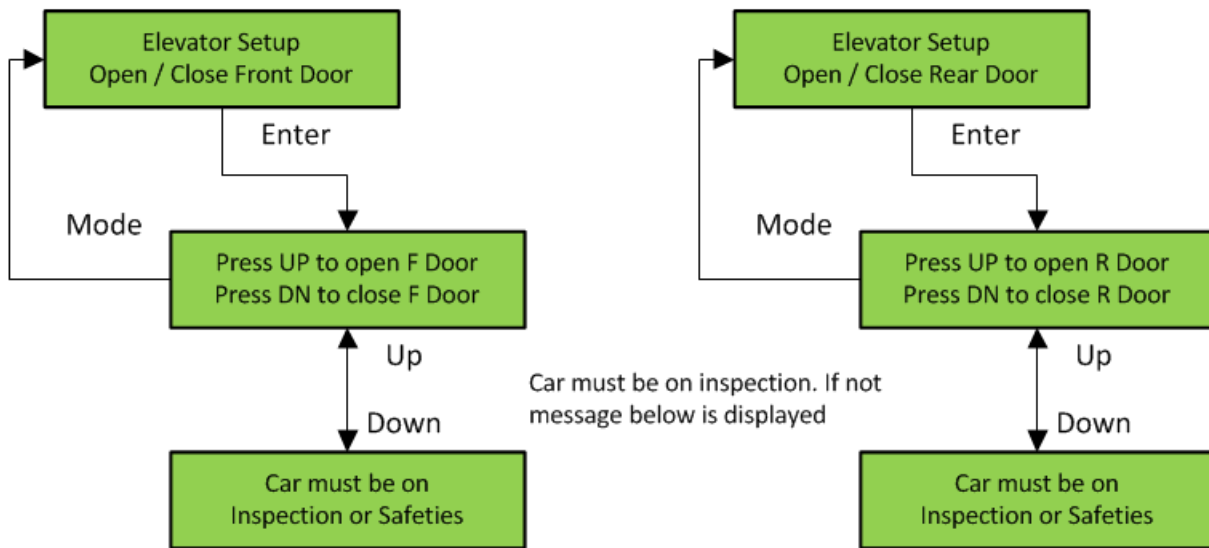

Figure 5-48: LCD Interface – Open / Close Front Door & Rear Door Submenus



5.2.47 Lift Brake On Inspection

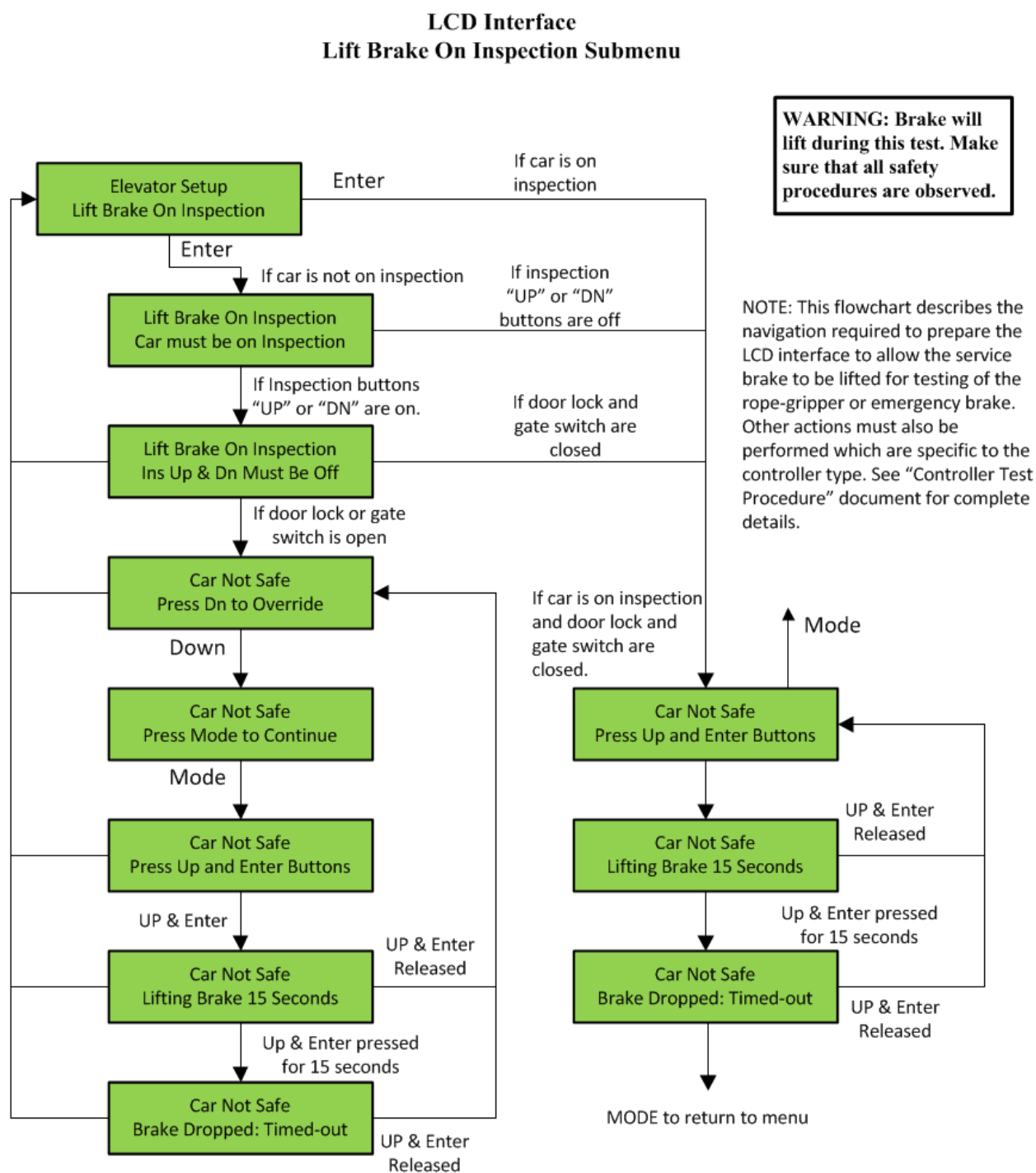

Figure 5-4927: LCD Interface – Lift Brake on Inspection Submenu

5.2.48 Load Weigher Setup

5.2.48.1 Setup Load Weigher

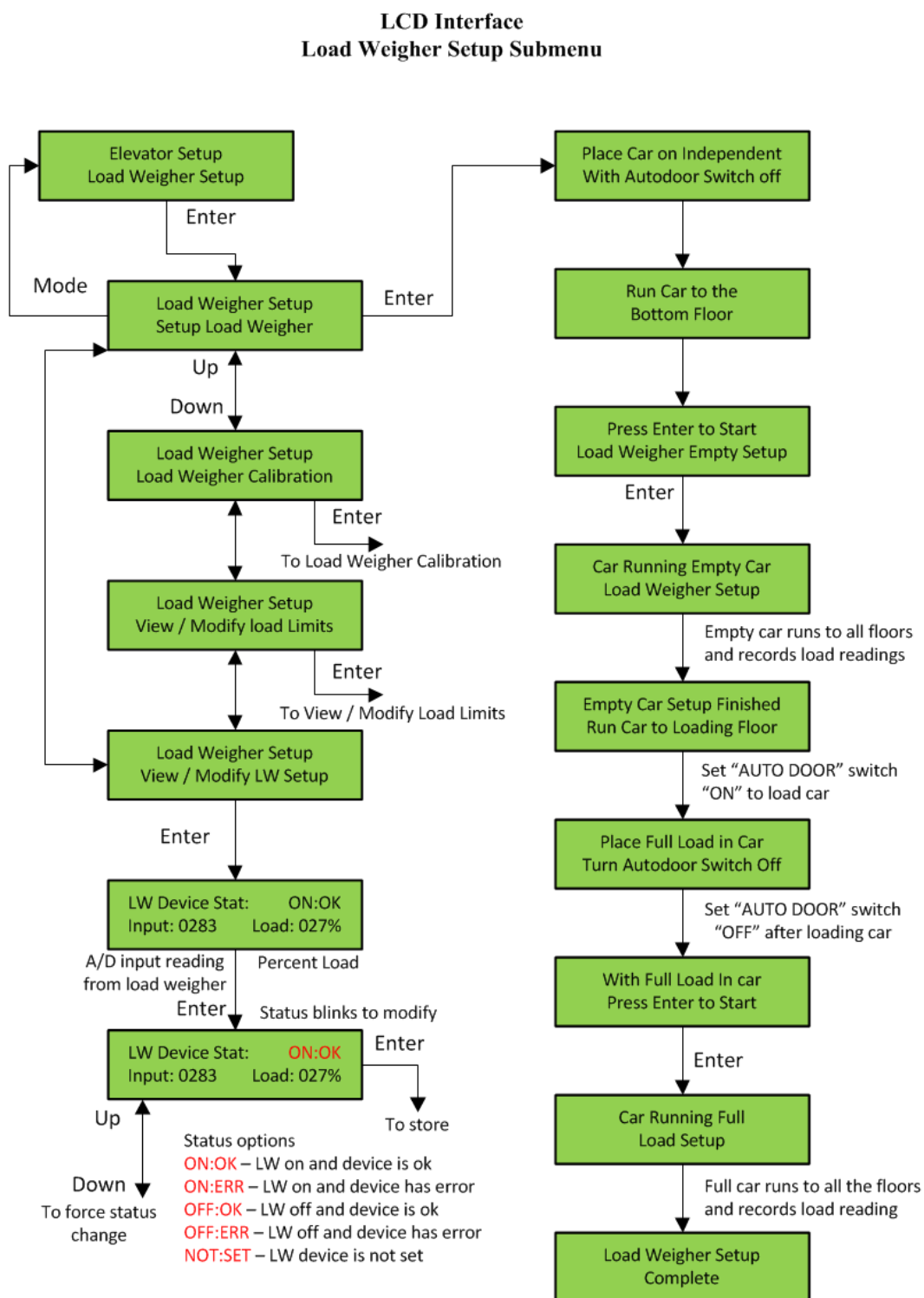

Figure 5-50: LCD Interface – Load Weigher Setup Submenu

5.2.48.2 View/Modify Load Limits

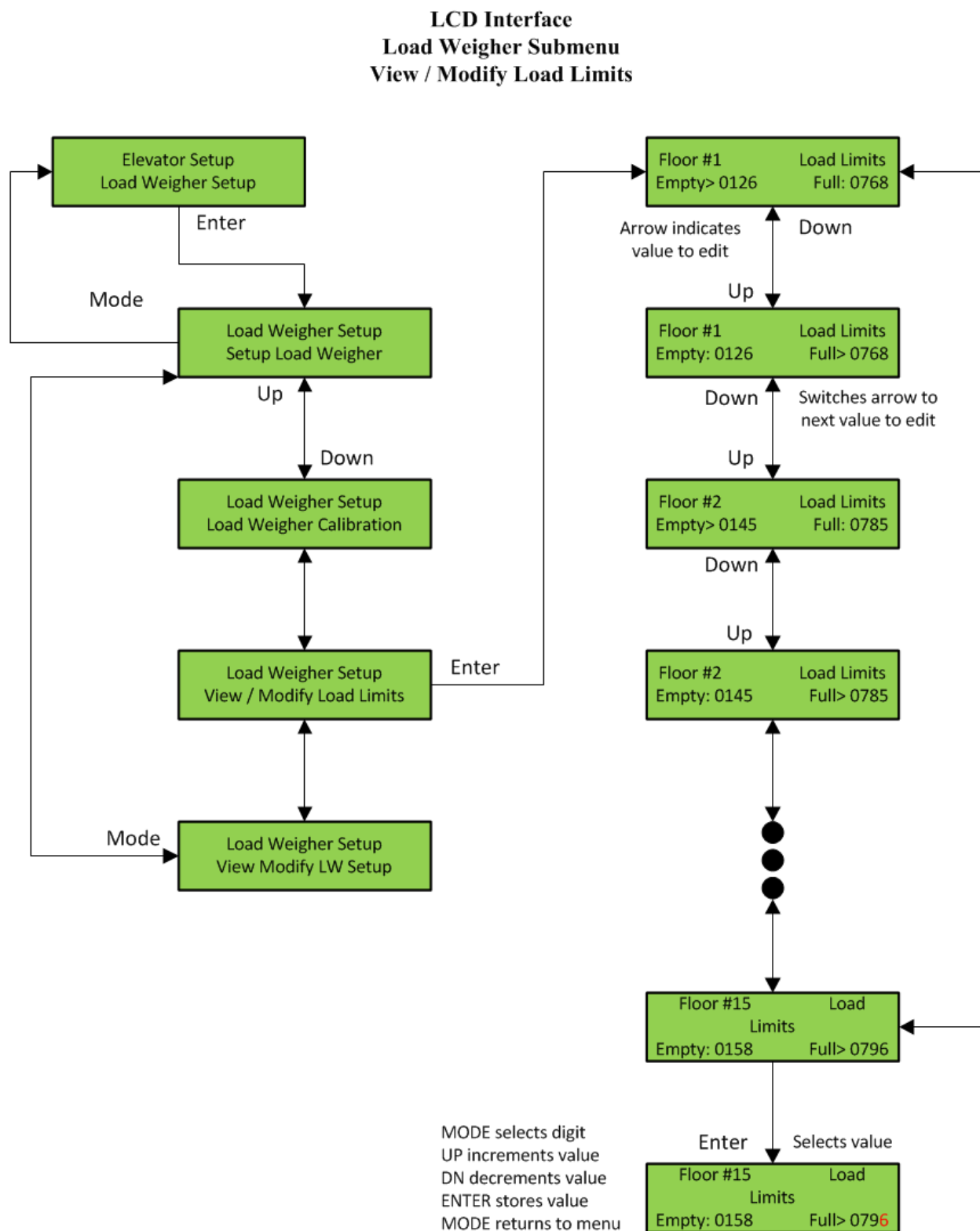

Figure 5-51: LCD Interface – Load Weigher View / Modify Load Limits Submenu

5.2.48.3 Calibrate Load Weigher

**LCD Interface  
Load Weigher Setup Submenu  
Calibrate Load Weigher**

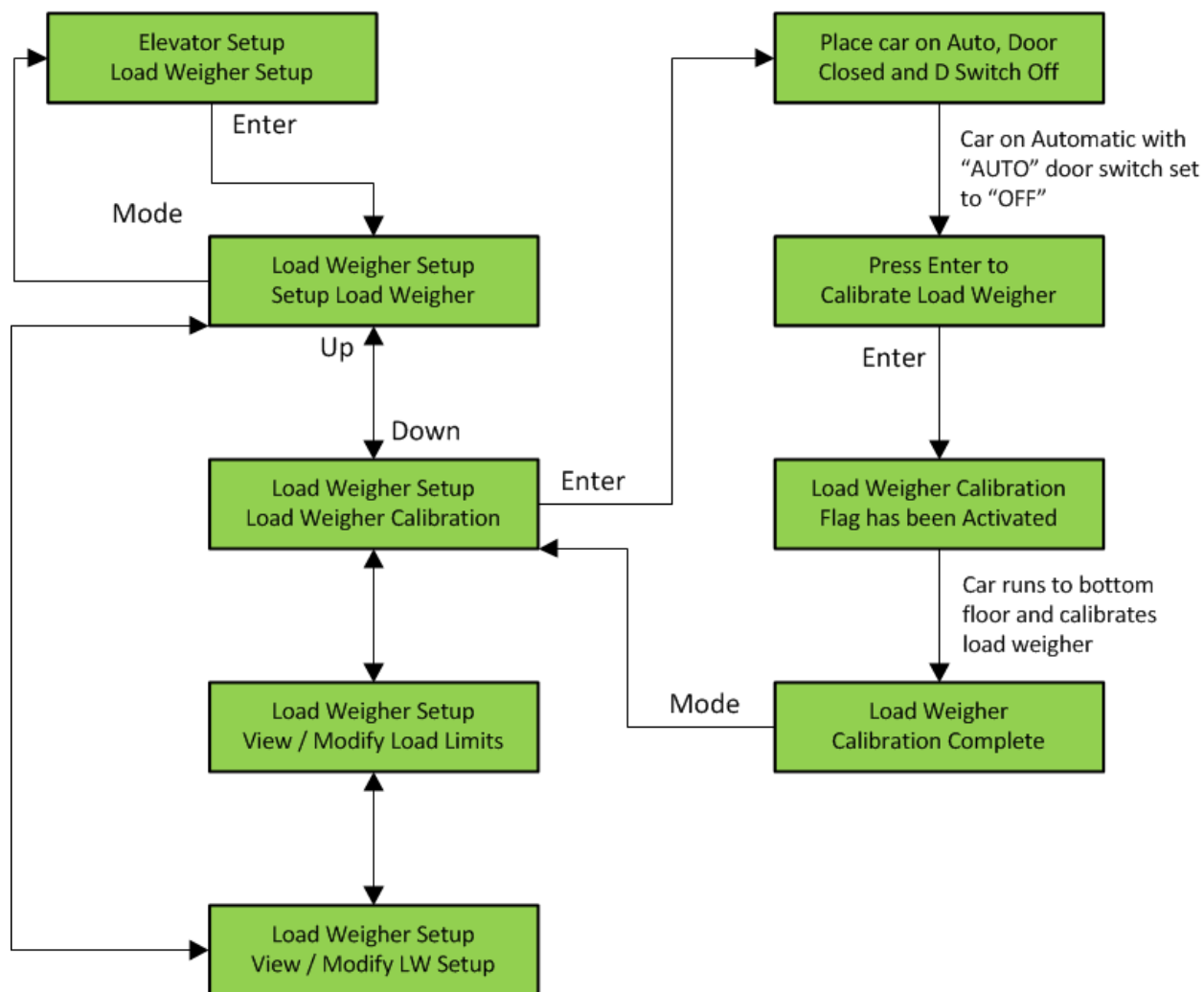

Figure 5-52: LCD Interface – Calibrate Load Weigher Setup Submenu

5.2.49 Car Buffer Test

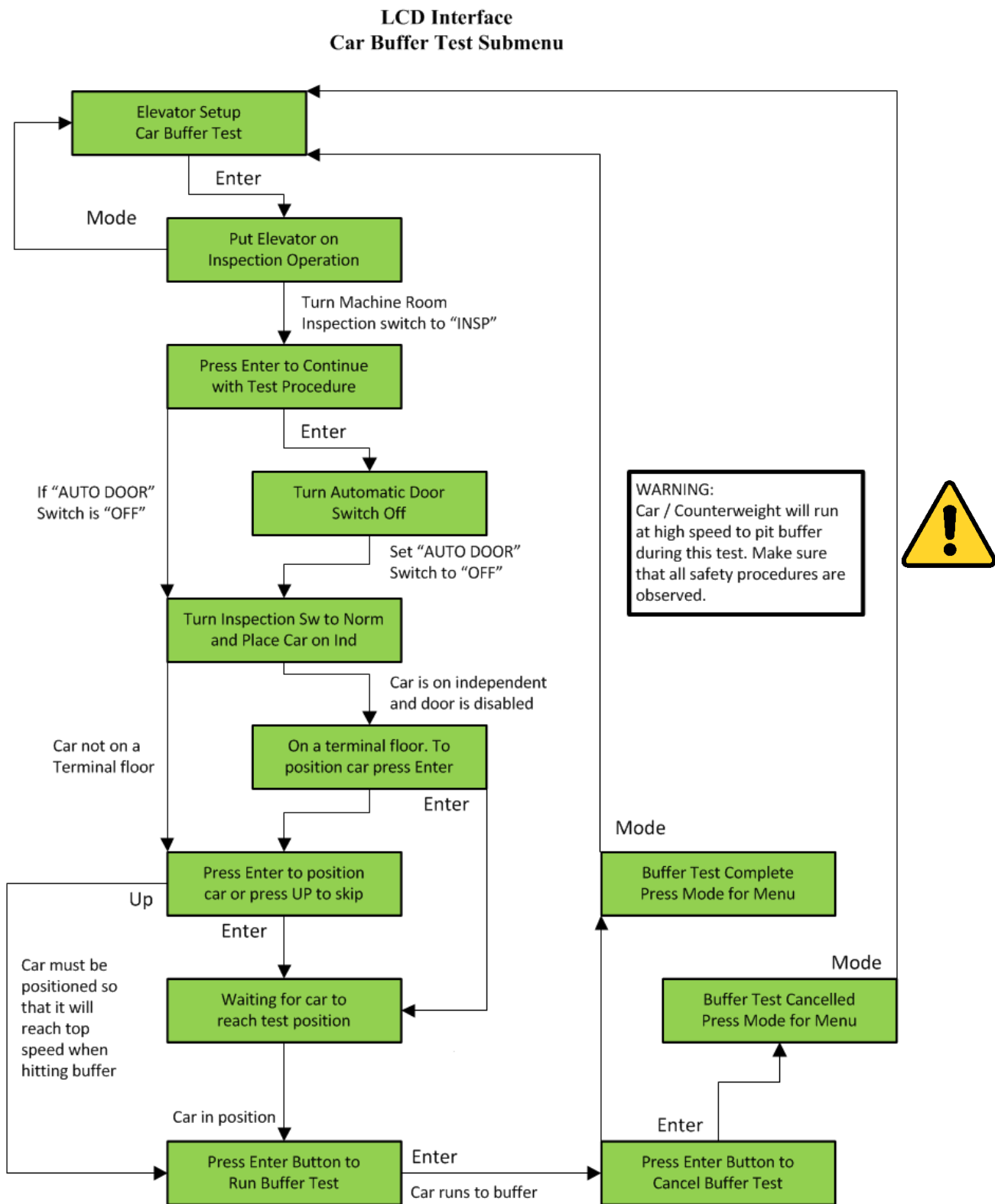
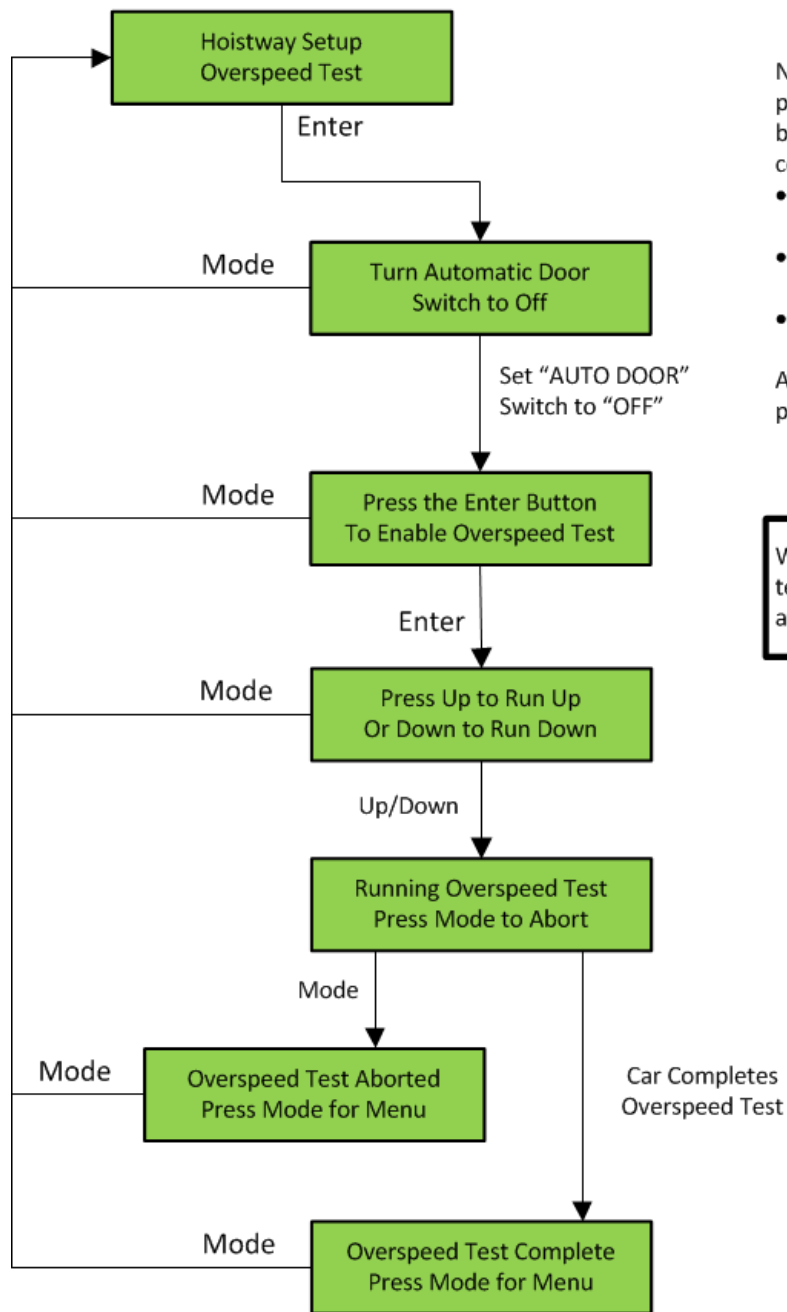

Figure 5-53: LCD Interface – Car Buffer Test Submenu

5.2.50 Overspeed Test

**LCD Interface  
Overspeed Test Submenu**



NOTE: Before performing Overspeed test procedure, the following parameters should be adjusted to force the car to run faster than contract speed.

- For DSD 412 drive - drive function #11 Motor RPM
- For HPV600/900 – drive parameter A1 Contract MTR Speed
- For KEB F5 – Set LL16 to 125% and then set LL15 to Overspeed Test.

After test s complete, return parameters to proper values for contract speed.

**WARNING:** Car will overspeed during this test. Make sure that all safety procedures are observed.



Figure 5-54: LCD Interface – Overspeed Test Submenu

5.2.51 Reset / View Faults

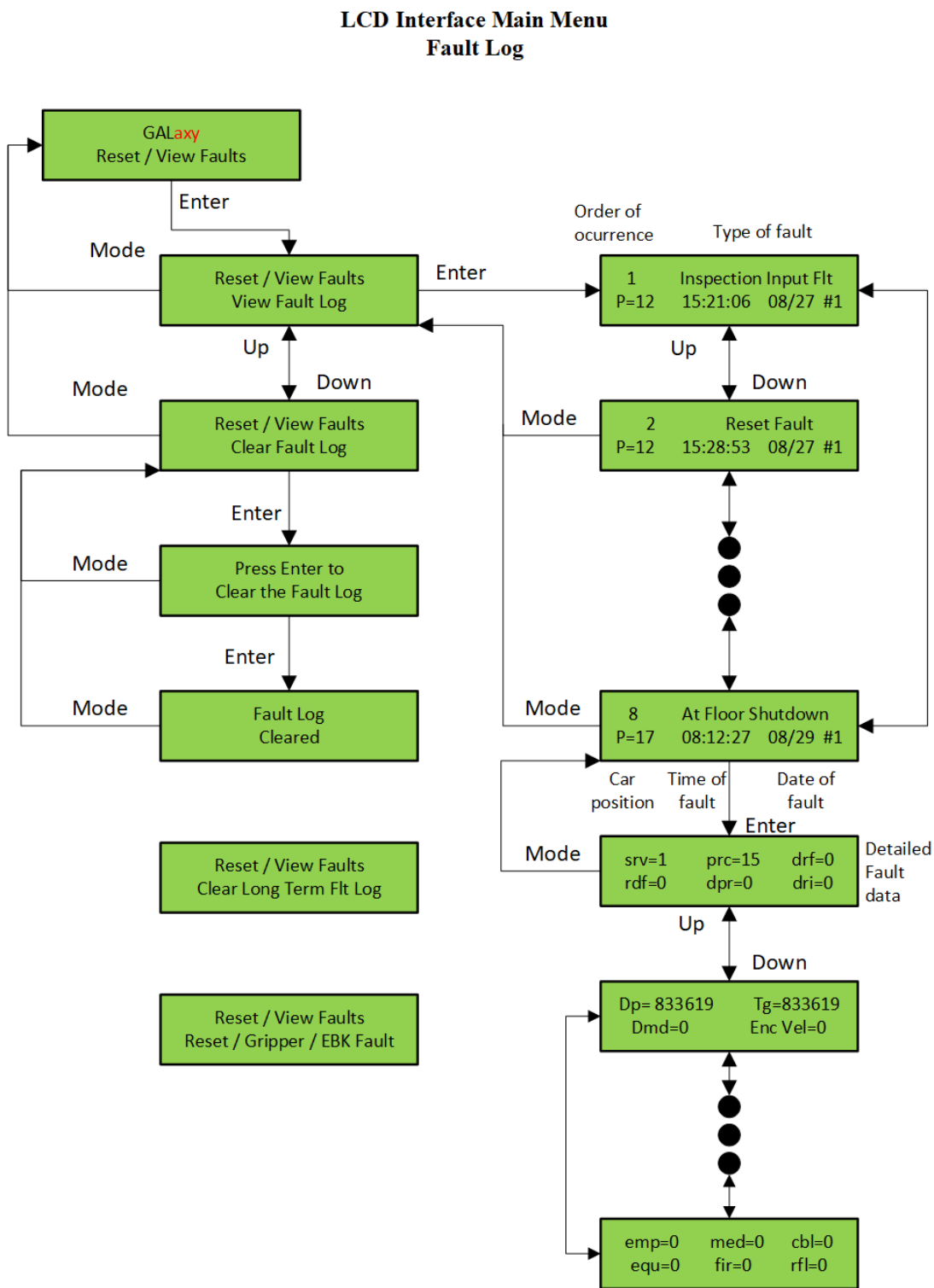

Figure 5-55: LCD Interface Main Menu – Fault Log

5.2.52 Reset Gripper / EBK Fault

**LCD Interface  
Reset Gripper Fault**

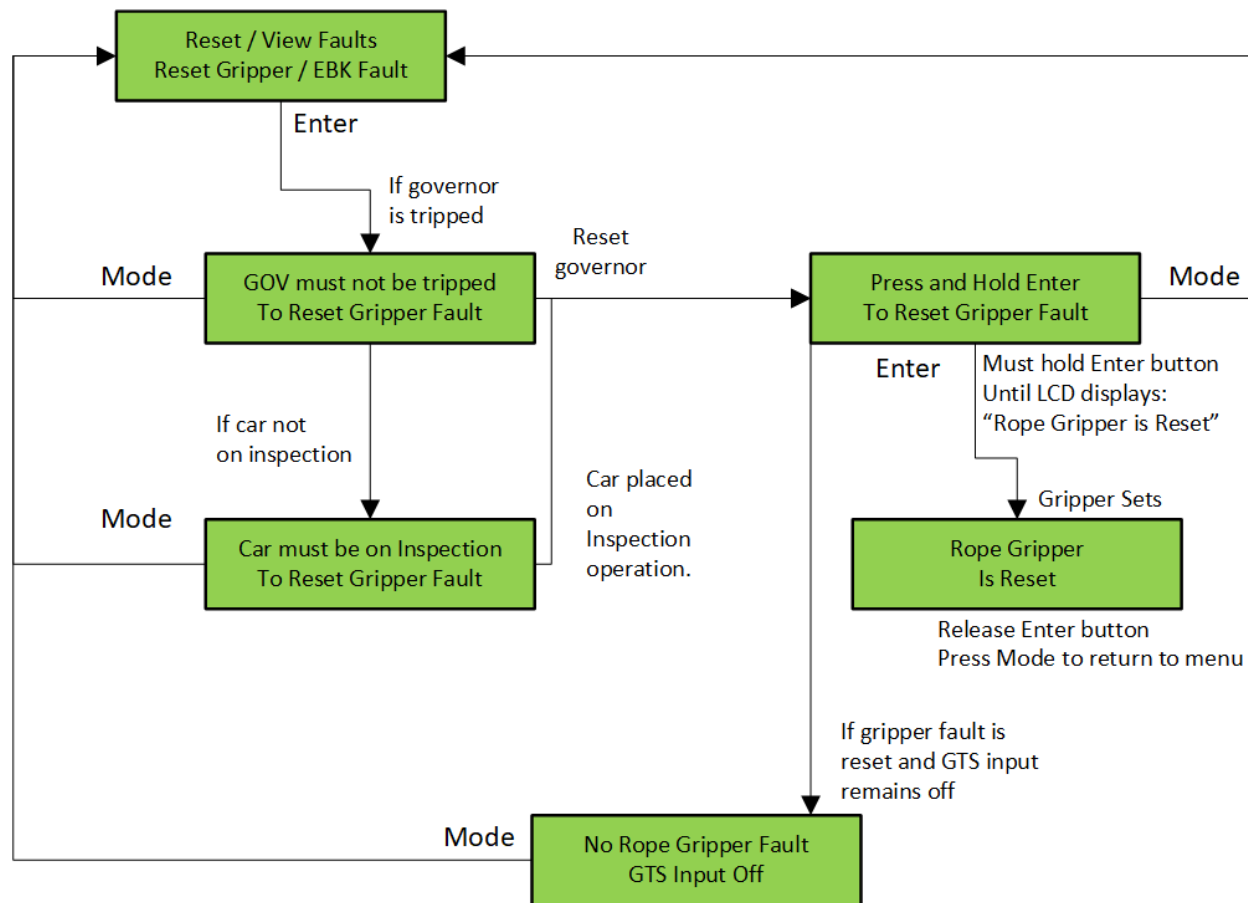

Figure 5-56: LCD Interface – Reset Gripper Fault Submenu



## Section 6 – System Faults & Detailed Faults

### 6.1 System Faults

Fault	Description	Possible Cause/Suggested Fix
Address Error	Safety Processor has an Invalid Address	Program Error
Adv PreTrq Start Flt	Did not get safe on advance pre-torque start	<ul style="list-style-type: none"> <li>• Advance pre-torque is enabled. When pre-torque is activated, the software waits for 5 seconds and expects the car to have moved by then. If there is no movement the fault gets declared. Possible Door operator or door lock failure prevented the elevator from running.</li> </ul>
APS P1 Camera CAN Flt	APS Selector Processor 1 on the APS Selector interface board is not communicating with the APS camera head on channel B.	<ul style="list-style-type: none"> <li>• Verify the RJ-45 connector from the selector camera to the selector interface board GALX-1133 is properly connected.</li> <li>• Verify that both LED's on the RJ-45 connector are blinking at 1 second intervals.</li> <li>• Make sure the CAT-6 cable is not run in parallel with any high voltage wires.</li> <li>• Replace the GALX-1133 board.</li> <li>• Replace the camera head.</li> </ul>
APS P1 DN Input Fault	APS Selector Processor 1 on the APS Selector interface board detected a Down Normal Limit input fault.	<ul style="list-style-type: none"> <li>• Processor 1 detected that the input for DN was off when the output was being turned on.</li> <li>• Faulty input, replace the input device.</li> <li>• Faulty output for DN. Replace the output device.</li> </ul>

Fault	Description	Possible Cause/Suggested Fix
APS P1 DZ Clip Fault	APS Selector Processor 1 on the APS Selector interface board detected a door zone clip missing.	<ul style="list-style-type: none"> <li>• Processor 1 detected a door zone clip missing at the same floor for three consecutive stops on channel B.</li> <li>• Verify that the door zone clip is roughly in the middle of channel A and B cameras. Place the clip in the proper position</li> <li>• If the clip is missing or broken, then replace the clip.</li> <li>• Go to the LCD Interface on the Main CPU and select the Dpy APS Sel Valid Clips menu under the Hoistway Tables menu. Under the display for ClpP1, a bit is set for each floor with a valid clip. Position the elevator at the floor that does not have the bit set and re-learn the floor position.</li> </ul>
APS P1 DZ Input Fault	APS Selector Processor 1 on the APS Selector interface board detected a door zone input fault.	<ul style="list-style-type: none"> <li>• Processor 1 detected that the input for DZ was off when the output was being turned on.</li> <li>• Faulty input, replace the input device.</li> <li>• Faulty output for DZ. Replace the output device.</li> </ul>
APS P1 Hoistway Init	APS Selector Processor 1 Hoistway Initialized for first time.	<ul style="list-style-type: none"> <li>• Should only occur on first time power up.</li> <li>• If this errors occurs on every power up then replace the APS Selector interface board.</li> </ul>
APS P1 HW Floor Flt	APS Selector Processor 1 on the APS Selector interface board has a hoistway learn flag set but does not have a valid floor table.	<ul style="list-style-type: none"> <li>• If the installation process to learn all the floors is not complete then then ignore this error.</li> <li>• Complete the learn process.</li> <li>• Go to the LCD Interface on the Main CPU and select the Dpy APS Sel Valid Floors menu under the Hoistway Tables menu. Under the display for FLRP1, a bit is set for each valid floor. Position the elevator at the floor that does not have the bit set and re-learn the floor position.</li> </ul>

Fault	Description	Possible Cause/Suggested Fix
APS P1 HW Flr Cnt Er	APS Selector Processor 1 on the APS Selector interface board has a floor count on a floor that is higher than the floor above.	<ul style="list-style-type: none"> <li>• If the installation process to learn all the floors is not complete then then ignore this error.</li> <li>• Complete the learn process.</li> <li>• Go to the LCD Interface on the Main CPU and select the Dpy APS Sel Valid Floors menu under the Hoistway Tables menu. Under the display for FLRP1, a bit is set for each valid floor. Position the elevator at the floor that does not have the bit set and re-learn the floor position.</li> </ul>
APS P1 HW Flr Cnt=0	APS Selector Processor 1 on the APS Selector interface board has a hoistway floor count value that is zero.	<ul style="list-style-type: none"> <li>• If the installation process to learn all the floors is not complete then then ignore this error.</li> <li>• Complete the learn process.</li> <li>• Go to the LCD Interface on the Main CPU and select the Dpy APS Sel Valid Floors menu under the Hoistway Tables menu. Under the display for FLRP1, a bit is set for each valid floor. Position the elevator at the floor that does not have the bit set and re-learn the floor position.</li> </ul>
APS P1 HW Setup Flt	APS Selector Processor 1 on the APS Selector interface board has a hoistway setup fault.	<ul style="list-style-type: none"> <li>• If the installation process to learn all the floors is not complete then then ignore this error.</li> <li>• Complete the learn process.</li> <li>• Go to the LCD Interface on the Main CPU and select the Dpy APS Sel Valid Floors menu under the Hoistway Tables menu. Under the display for FLRP1, a bit is set for each valid floor. Position the elevator at the floor that does not have the bit set and re-learn the floor position.</li> </ul>
APS P1 Prg Fl Cnt Dif	APS Selector Processor 1 returned a different floor count than what was sent from Processor 2.	<ul style="list-style-type: none"> <li>•Verify that both MCU LEDs are blinking on the APS selector interface board.</li> <li>•Verify that the COMSPI LED driven by Processor 2 is blinking on the APS selector interface board.</li> </ul>
APS P1 Prog Cmd Diff	APS Selector Processor 1 returned a different command than what was sent from Processor 2.	<ul style="list-style-type: none"> <li>•Verify that both MCU LEDs are blinking on the APS selector interface board.</li> <li>•Verify that the COMSPI LED driven by Processor 2 is blinking on the APS selector interface board.</li> </ul>

Fault	Description	Possible Cause/Suggested Fix
APS P1 Prog Flr Diff	APS Selector Processor 1 returned a different floor number than what was sent from Processor 2.	<ul style="list-style-type: none"> <li>• Verify that both MCU LEDs are blinking on the APS selector interface board.</li> <li>• Verify that the COMSPI LED driven by Processor 2 is blinking on the APS selector interface board.</li> </ul>
APS P1 Prog Time-Out	APS Selector Processor 1 did not respond to Processor 2 within the required time during a floor count upload.	<ul style="list-style-type: none"> <li>• Verify that both MCU LEDs are blinking on the APS selector interface board.</li> <li>• Verify that the COMSPI LED driven by Processor 2 is blinking on the APS selector interface board.</li> </ul>
APS P1 SS Input Fault	APS Selector Processor 1 on the APS Selector interface board detected that there is no voltage on the SOK terminal of the Selector Board.	<ul style="list-style-type: none"> <li>• Processor 1 detected that the input for SOK was off when the SOK Relay output was being turned on.</li> <li>• This fault will also be display if there is no voltage on the SOK input terminal. Check the connection from EXIT to SOK. Verify that there is voltage on both EXIT and SOK terminals.</li> <li>• Faulty input device. Replace the board.</li> </ul>
APS P1 SS Open Fault	APS Selector Processor 1 on the APS Selector interface board detected that there is no voltage on the SOK terminal of the Selector Board.	<ul style="list-style-type: none"> <li>• Processor 1 detected that the SOK input terminal of the selector board has no voltage.</li> <li>• Verify that there is voltage on both EXIT and SOK terminals.</li> <li>• Check the voltage leading up to the EXIT terminal.</li> <li>• Check the connection from EXIT to SOK.</li> <li>• Faulty input device. Replace the board.</li> </ul>
APS P1 UN Input Fault	APS Selector Processor 1 on the APS Selector interface board detected a Up Normal Limit input fault.	<ul style="list-style-type: none"> <li>• Processor 1 detected that the input for UN was off when the output was being turned on.</li> <li>• Faulty input, replace the input device.</li> <li>• Faulty output for UN. Replace the output device.</li> </ul>
APS P1 Vel Check Flt	APS Selector Processor 1 on the APS Selector interface board detected a Velocity Check fault between channel A and channel B.	<ul style="list-style-type: none"> <li>• Verify that both camera heads are clean, aligned and have a good contrast ratio (see diagnostic menu)</li> <li>• Check for communications errors for the camera head to the selector interface board GALX-1133</li> </ul>

Fault	Description	Possible Cause/Suggested Fix
APS P2 Camera CAN Flt	APS Selector Processor 2 on the APS Selector interface board is not communicating with the APS camera head on channel B.	<ul style="list-style-type: none"> <li>• Verify the RJ-45 connector from the selector camera to the selector interface board GALX-1133 is properly connected.</li> <li>• Verify that both LED's on the RJ-45 connector are blinking at 1 second intervals.</li> <li>• Make sure the CAT-6 cable is not run in parallel with any high voltage wires.</li> <li>• Replace the GALX-1133 board.</li> <li>• Replace the camera head.</li> </ul>
APS P2 DN Input Fault	APS Selector Processor 2 on the APS Selector interface board detected a Down Normal Limit input fault.	<ul style="list-style-type: none"> <li>• Processor 2 detected that the input for DN was off when the output was being turned on.</li> <li>• Faulty input, replace the input device.</li> <li>• Faulty output for DN. Replace the output device.</li> </ul>
APS P2 DZ Clip Fault	APS Selector Processor 2 on the APS Selector interface board detected a door zone clip missing.	<ul style="list-style-type: none"> <li>• Processor 2 detected a door zone clip missing at the same floor for three consecutive stops on channel B.</li> <li>• Verify that the door zone clip is roughly in the middle of channel A and B cameras. Place the clip in the proper position</li> <li>• If the clip is missing or broken, then replace the clip.</li> <li>• Go to the LCD Interface on the Main CPU and select the Dpy APS Sel Valid Clips menu under the Hoistway Tables menu. Under the display for ClpP2, a bit is set for each floor with a valid clip. Position the elevator at the floor that does not have the bit set and re-learn the floor position.</li> </ul>
APS P2 DZ Input Fault	APS Selector Processor 2 on the APS Selector interface board detected a door zone input fault.	<ul style="list-style-type: none"> <li>• Processor 2 detected that the input for DZ was off when the output was being turned on.</li> <li>• Faulty input, replace the input device.</li> <li>• Faulty output for DZ. Replace the output device.</li> </ul>
APS P2 FVars Init	APS Selector Processor 2 Field Variables Initialized for first time.	<ul style="list-style-type: none"> <li>• Should only occur on first time power up.</li> <li>• If this errors occurs on every power up then replace the board.</li> </ul>

Fault	Description	Possible Cause/Suggested Fix
APS P2 Hoistway Init	APS Selector Processor 2 Hoistway Initialized for first time.	<ul style="list-style-type: none"> <li>• Should only occur on first time power up.</li> <li>• If this errors occurs on every power up then replace the board.</li> </ul>
APS P2 HW Floor Flt	APS Selector Processor 2 on the APS Selector interface board has a hoistway learn flag set but does not have a valid floor table.	<ul style="list-style-type: none"> <li>• If installation process to learn all the floors is not complete then then ignore this error.</li> <li>• Complete the learn process.</li> <li>• Go to the LCD Interface on the Main CPU and select the Dpy APS Sel Valid Floors menu under the Hoistway Tables menu. Under the display for FLRP2, a bit is set for each valid floor. Position the elevator at the floor that does not have the bit set and re-learn the floor position.</li> </ul>
APS P2 HW Flr Cnt Er	APS Selector Processor 2 on the APS Selector interface board has a floor count on a floor that is higher than the floor above.	<ul style="list-style-type: none"> <li>• If installation process to learn all the floors is not complete then then ignore this error.</li> <li>• Complete the learn process.</li> <li>• Go to the LCD Interface on the Main CPU and select the Dpy APS Sel Valid Floors menu under the Hoistway Tables menu. A bit is set for each valid floor. Position the elevator at the floor that does not have the bit set and re-learn the floor position.</li> </ul>
APS P2 HW Flr Cnt=0	APS Selector Processor 2 on the APS Selector interface board has a hoistway floor count value that is zero.	<ul style="list-style-type: none"> <li>• If installation process to learn all the floors is not complete then then ignore this error.</li> <li>• Complete the learn process.</li> <li>• Go to the LCD Interface on the Main CPU and select the Dpy APS Sel Valid Floors menu under the Hoistway Tables menu. Under the display for FLRP2, a bit is set for each valid floor. Position the elevator at the floor that does not have the bit set and re-learn the floor position.</li> </ul>
APS P2 HW Setup Flt	APS Selector Processor 2 on the APS Selector interface board has a hoistway setup fault.	<ul style="list-style-type: none"> <li>• If the installation process to learn all the floors is not complete then then ignore this error.</li> <li>• Complete the learn process.</li> <li>• Go to the LCD Interface on the Main CPU and select the Dpy APS Sel Valid Floors menu under the Hoistway Tables menu. Under the display for FLRP2, a bit is set for each valid floor. Position the elevator at the floor that does not have the bit set and re-learn the floor position.</li> </ul>

Fault	Description	Possible Cause/Suggested Fix
APS P2 SP CAN Com Flt	APS Selector Processor 2 on the APS Selector interface board is not communicating on the SPCAN bus with the NTS processor or the Safety Processor.	<ul style="list-style-type: none"> <li>• Verify proper twisted pair wires to the SPCH and SPCL terminals on the GALX-1102 board.</li> <li>• Noise on the CAN Bus, verify that the shield wire is connected according to the job print.</li> </ul>
APS P2 SPI Com Fault	APS Selector Processor 2 is not communicating through the SPI serial port with Processor 1 on the APS Selector interface board.	<ul style="list-style-type: none"> <li>• Cycle the power on the board. If the problem persists, replace the board.</li> </ul>
APS P2 SS Input Fault	APS Selector Processor 2 on the APS Selector interface board detected a SOK input is off while turning on the SOK Relay output.	<ul style="list-style-type: none"> <li>• Processor 2 detected that the input for SOK was off when the SOK Relay output was being turned on.</li> <li>• This fault will also be display if there is no voltage on the SOK input terminal. Check the connection from EXIT to SOK. Verify that there is voltage on both EXIT and SOK terminals.</li> <li>• Faulty input device. Replace the board.</li> </ul>
APS P2 SS Open Fault	APS Selector Processor 2 on the APS Selector interface board detected that there is no voltage on the SOK terminal of the Selector Board.	<ul style="list-style-type: none"> <li>• Processor 2 detected that the SOK input terminal of the selector board has no voltage.</li> <li>• Verify that there is voltage on both EXIT and SOK terminals.</li> <li>• Check the voltage leading up to the EXIT terminal.</li> <li>• Check the connection from EXIT to SOK.</li> <li>• Faulty input device. Replace the board.</li> </ul>
APS P2 UN Input Fault	APS Selector Processor 2 on the APS Selector interface board detected a Up Normal Limit input fault.	<ul style="list-style-type: none"> <li>• Processor 2 detected that the input for UN was off when the output was being turned on.</li> <li>• Faulty input, replace the input device.</li> <li>• Faulty output for UN. Replace the output device.</li> </ul>

Fault	Description	Possible Cause/Suggested Fix
APS Sel Brd CAN Error	APS (Absolute Position System) Interface Board CAN Comm Fault	<ul style="list-style-type: none"> <li>• Verify the RJ-45 connector from the selector camera to the selector interface board GALX-1133 is properly connected.</li> <li>• Verify that both LED's on the RJ-45 connector are blinking at 1 second intervals.</li> <li>• Make sure the CAT-6 cable is not run in parallel with any high voltage wires.</li> <li>• Replace the GALX-1133 board.</li> <li>• Replace the camera head.</li> </ul>
APS Sel Brd Vel Fault	APS Velocity Verification Fault (A and B channels do not match)	<ul style="list-style-type: none"> <li>• Verify that both camera heads are clean, aligned and have a good contrast ratio (see diagnostic menu)</li> <li>• Check for communications errors for the camera head to the selector interface board GALX-1133.</li> </ul>
APS Sel P1 clip Fault	APS Selector Board P1 DZ Clip fault	<ul style="list-style-type: none"> <li>• Processor 1 detected a door zone clip missing at the same floor for three consecutive stops on channel B.</li> <li>• Verify that the door zone clip is roughly in the middle of channel A and B cameras. Place the clip in the proper position</li> <li>• If the clip is missing or broken, then replace the clip.</li> <li>• Go to the LCD Interface on the Main CPU and select the Dpy APS Sel Valid Clips menu under the Hoistway Tables menu. Under the display for ClpP1, a bit is set for each floor with a valid clip. Position the elevator at the floor that does not have the bit set and re-learn the floor position.</li> </ul>
APS Sel P1 IO Fault	APS Selector Board P1 DZ, DN, UN or SS input fault	<ul style="list-style-type: none"> <li>• Processor 1 detected that the input for DZ, DN, UN or SS was off when the corresponding output was being turned on.</li> <li>• Faulty input, replace the input device.</li> <li>• Faulty output for DZ, DN or UN. Replace the output device.</li> <li>• Faulty Selector Safe Relay. Replace the relay.</li> <li>• Check the MRCAN Device fault for the APS Selector for more details.</li> </ul>



Fault	Description	Possible Cause/Suggested Fix
APS Sel P1 SS Open	APS Selector Board P1 SS Open Fault	<ul style="list-style-type: none"> <li>• Processor 1 detected that the Selector Safe Relay is not on when expected. This relay will open up the Safety String.</li> <li>• Check for other APS Selector board fault and correct the condition.</li> <li>• Faulty Selector Safe Relay. Replace the relay.</li> <li>• Check the MRCAN Device fault for the APS Selector for more details.</li> </ul>
APS Sel P2 clip Fault	APS Selector Board P2 DZ Clip fault	<ul style="list-style-type: none"> <li>• Processor 2 detected a door zone clip missing at the same floor for three consecutive stops on channel B.</li> <li>• Verify that the door zone clip is roughly in the middle of channel A and B cameras. Place the clip in the proper position</li> <li>• If the clip is missing or broken, then replace the clip.</li> <li>• Go to the LCD Interface on the Main CPU and select the Dpy APS Sel Valid Clips menu under the Hoistway Tables menu. Under the display for ClpP2, a bit is set for each floor with a valid clip. Position the elevator at the floor that does not have the bit set and re-learn the floor position.</li> </ul>
APS Sel P2 IO Fault	APS Selector Board P2 DZ, DN, UN or SS input fault	<ul style="list-style-type: none"> <li>• Processor 2 detected that the input for DZ, DN, UN or SS was off when the corresponding output was being turned on.</li> <li>• Faulty input, replace the input device.</li> <li>• Faulty output for DZ, DN or UN. Replace the output device.</li> <li>• Faulty Selector Safe Relay. Replace the relay.</li> <li>• Check the MRCAN Device fault for the APS Selector for more details.</li> </ul>
APS Sel P2 SS Open	APS Selector Board P2 SS open Fault	<ul style="list-style-type: none"> <li>• Processor 2 detected that the Selector Safe Relay is not on when expected. This relay will open up the Safety String.</li> <li>• Check for other APS Selector board fault and correct the condition.</li> <li>• Faulty Selector Safe Relay. Replace the relay.</li> <li>• Check the MRCAN Device fault for the APS Selector for more details.</li> </ul>

Fault	Description	Possible Cause/Suggested Fix
APS Selector CAN Err	APS (Absolute Position System) Selector CAN comm error	<ul style="list-style-type: none"> <li>• Verify the proper connection for the twisted pair wires to the ENC-H and ENC-L terminals on GALX-1100AN CPU Board.</li> <li>• Noise on the CAN Bus, verify that the shield wire is connected according to the job print.</li> </ul>
APS Selector Fault	APS (Absolute Position System) Selector Fault	<ul style="list-style-type: none"> <li>• This fault may occur due to either an internal error, communications error, position validation error, velocity validation error on the APS Selector.</li> <li>• Possible solution is to clean the APS tape with damp soft cloth.</li> <li>• Check the MRCAN Device fault for the APS Selector for more details.</li> </ul>
ASV Time-out Car 1	Automatic Service Time-out Car 1	<ul style="list-style-type: none"> <li>• Car was not able to answer group hall call within the automatic service time-out timer. Look for fault condition on car.</li> </ul>
ASV Time-out Car 2	Automatic Service Time-out Car 2	<ul style="list-style-type: none"> <li>• Car was not able to answer group hall call within the automatic service time-out timer. Look for fault condition on car.</li> </ul>
ASV Time-out Car 3	Automatic Service Time-out Car 3	<ul style="list-style-type: none"> <li>• Car was not able to answer group hall call within the automatic service time-out timer. Look for fault condition on car.</li> </ul>
ASV Time-out Car 4	Automatic Service Time-out Car 4	<ul style="list-style-type: none"> <li>• Car was not able to answer group hall call within the automatic service time-out timer. Look for fault condition on car.</li> </ul>
ASV Time-out Car 5	Automatic Service Time-out Car 5	<ul style="list-style-type: none"> <li>• Car was not able to answer group hall call within the automatic service time-out timer. Look for fault condition on car.</li> </ul>
ASV Time-out Car 6	Automatic Service Time-out Car 6	<ul style="list-style-type: none"> <li>• Car was not able to answer group hall call within the automatic service time-out timer. Look for fault condition on car.</li> </ul>

Fault	Description	Possible Cause/Suggested Fix
ASV Time-out Car 7	Automatic Service Time-out Car 7	<ul style="list-style-type: none"> <li>• Car was not able to answer group hall call within the automatic service time-out timer. Look for fault condition on car.</li> </ul>
ASV Time-out Car 8	Automatic Service Time-out Car 8	<ul style="list-style-type: none"> <li>• Car was not able to answer group hall call within the automatic service time-out timer. Look for fault condition on car.</li> </ul>
At Floor Shutdown	At floor shutdown	<ul style="list-style-type: none"> <li>• Car faulted out while at floor. Look at the fault log for a different fault at the same time to determine cause of failure</li> </ul>
Aut Swg Fr Door Open	Automatic Swing Front Door Open Fault. The swing door can only close by removing the door open signal and allowing the door to close mechanically. With this fault the door stayed open when the open signal was removed.	<ul style="list-style-type: none"> <li>• Verify that the ADO output has not failed on. If so then replace the output chip.</li> <li>• Verify that the door is not binding and is preventing from closing.</li> </ul>
Aut Swg Rr Door Open	Automatic Swing Rear Door Open Fault. The swing door can only close by removing the door open signal and allowing the door to close mechanically. With this fault the door stayed open when the open signal was removed.	<ul style="list-style-type: none"> <li>• Verify that the ADOR output has not failed on. If so then replace the output chip.</li> <li>• Verify that the door is not binding and is preventing from closing.</li> </ul>
Binary Input Fault	The floor position, read from binary inputs on the selector, does not match the car position.	<ul style="list-style-type: none"> <li>• Excessive wear on the selector guides.</li> <li>• Preset magnet is missing or misaligned.</li> <li>• Faulty Hall Effect sensor on sensor board.</li> <li>• Faulty output on selector driver board.</li> <li>• Faulty BP1, BP2 or BP4 input</li> </ul>

Fault	Description	Possible Cause/Suggested Fix
BKS Fault Slowdown	BKS Brake Switch Fault Slowdown. The brake lift switch dropped during the run causing the car to slowdown at the next available floor	<ul style="list-style-type: none"> <li>• Faulty brake lift switch.</li> <li>• Low brake hold voltage</li> </ul>
Bot Door Lock Fault	The Bottom Door Lock failed on while the door was open.	Faulty door lock. <ul style="list-style-type: none"> <li>• Door lock not adjusted properly.</li> <li>• Jumper placed on door lock circuit.</li> <li>• Faulty wiring to DLB input.</li> <li>• Faulty DLB and DLB-1 inputs (For this to occur both DLB and DLB-1 inputs must fail on).</li> <li>• DOL input failed. Replace DOL input chip.</li> <li>• Door operator open limit DOL is not adjusted properly</li> </ul>
Bot Final Limit Flt	Bottom Final Limit Open	<ul style="list-style-type: none"> <li>• Car traveled onto the bottom final limit.</li> <li>• Faulty wiring of the final limit circuit.</li> </ul>
Brake Drop Fault	Brake failed to drop. The BKS input did not close while stopped.	<ul style="list-style-type: none"> <li>• Improper adjustment of brake switch.</li> <li>• Brake failed to drop.</li> </ul>
Brake Pick Fault	Brake failed to pick. The BKS input did not open during the run.	<ul style="list-style-type: none"> <li>• Improper adjustment of brake switch.</li> <li>• Brake failed to pick.</li> </ul>

Fault	Description	Possible Cause/Suggested Fix
Brake Test Stall Flt	<p>Brake Test Stall Fault. The elevator stalled during a brake test. A stall timer is running during the test using the Learn HW Stall time in the Car Timers menu. This is a protection timer that should never time-out. In the event that the car does not move during the test, the 6 second velocity timer should always expire first.</p>	<ul style="list-style-type: none"> <li>• Make sure the elevator can run properly at high speed.</li> <li>• Make sure the Learn HW Stall timer is set to 30 seconds or higher. The value set during a successful automatic hoistway learn would work fine.</li> </ul>
Brake Test UN/DN Flt	<p>Brake Test UN/DN Fault. The elevator hit the UN limit running in the up direction or DN limit running in the down direction during a brake test. The car will abort the brake test immediately if it is approaching or hits a terminal limit.</p>	<ul style="list-style-type: none"> <li>• Test run in the direction of the terminal floor.</li> <li>• UN or DN input failed or turned off unexpectedly during the test. Try to run the test again while monitoring the status of the UN and DN inputs.</li> <li>• UN or DN input off prior to starting the test. Check the status of the UN and DN inputs prior to the test and make sure that inputs work as expected.</li> <li>• Selector and/or limit not setup or adjusted properly.</li> </ul>
Brake Test UT/DT Flt	<p>Brake Test UT/DT Fault. The elevator hit the UT limit running in the up direction or DT limit running in the down direction during a brake test. The car will abort the brake test immediately if it is approaching or hits a terminal limit.</p>	<ul style="list-style-type: none"> <li>• Test run in the direction of the terminal floor.</li> <li>• UT or DT input failed or turned off unexpectedly during the test. Try to run the test again while monitoring the status of the UT and DT inputs.</li> <li>• UT or DT input off prior to starting the test. Check the status of the UT and DT inputs prior to the test and make sure that inputs work as expected.</li> <li>• Selector and/or limit not setup or adjusted properly.</li> </ul>

Fault	Description	Possible Cause/Suggested Fix
BRK CAN Com Error	Brake Board Can Communication Error.	<ul style="list-style-type: none"> <li>• Faulty Can communication wire connection. Verify proper twisted pair wires to the CANH and CANL terminals on the brake board.</li> <li>• Noise on the Can bus. Verify that the shield wire is connected according to the job print.</li> </ul>
Brk Flt Set EM Brake	Emergency brake set from brake fault	<ul style="list-style-type: none"> <li>• 'Brake Lift Sw' parameter is set to 2. There was a brake fault and this triggered an emergency brake/ gripper fault</li> </ul>
Brk Flt Set Gripper	<p>The Rope Gripper was tripped when the brake did not drop. The brake switch adjustable variable Can be set to only show the brake drop fault if the brake does not drop.</p>	<ul style="list-style-type: none"> <li>• Improper adjustment of brake switch.</li> <li>• Brake failed to drop.</li> </ul>
BRK I/O Failed Off	<p>The BRK input or output has failed off. The BRK coil is wired through a NO contact of MC, a NO regulator release contact of the drive (DON) and a BRK triac of the controller.</p>	<ul style="list-style-type: none"> <li>• Improper wiring of the brake BRK coil. Refer to prints for wire connections.</li> <li>• Faulty BRKi input. Replace BRKi input chip on the GALX-1102 board.</li> <li>• Faulty BRK output. Replace BRK output chip on the GALX-1102 board.</li> </ul>
BRK I/O Failed On	<p>The BRK input or output has failed on.</p>	<ul style="list-style-type: none"> <li>• Improper wiring of the brake BRK coil. Refer to prints for wire connections.</li> <li>• Faulty BRKi input. Replace BRKi input chip on the GALX-1102 board.</li> <li>• Faulty BRK output. Replace BRK output chip on the GALX-1102 board.</li> </ul>
BRK Low DC Bus Volts	<p>DC Bus Voltage is less than 80% of expected</p>	<ul style="list-style-type: none"> <li>• Incorrect Setting of Line to Line Brake voltage in Adjustable Variables</li> <li>• Incorrect dip-switch setting for Three Phase or Single Phase</li> <li>• Low Line Voltage</li> <li>• Rectifiers Blown or have bad connection</li> </ul>

Fault	Description	Possible Cause/Suggested Fix
BRK No Currnt w/Volt	Reading a resistance value (Vout/Aout) of 1000Ω or greater	<ul style="list-style-type: none"> <li>• No Brake Connected</li> <li>• Bad Current Sensor</li> <li>• Check if board is low current or high current board</li> </ul>
BRK No DC Bus Volts	DC Bus Voltage is less than 5VDC	<ul style="list-style-type: none"> <li>• No AC Voltage Coming into AC1-AC2-AC3</li> <li>• Rectifiers Blown or have bad Connection</li> </ul>
BRK No Output Volts	If no DCBus Faults, Requested Output Voltage is greater than 0, Actual Output voltage is less than 3VDC	<ul style="list-style-type: none"> <li>• IGBT Not Gating</li> </ul>
BRK Over Current Flt	Average Current is higher than Preset Limit (based on board configuration)	<ul style="list-style-type: none"> <li>• IGBT Shorted</li> <li>• Free Wheeling Diode Shorted</li> <li>• Gating Circuitry Shorted ON</li> </ul>
BRK Over Voltage Flt	Output Voltage is at least 20V greater than the Voltage Requested.	<ul style="list-style-type: none"> <li>• IGBT Shorted</li> <li>• Gating Circuitry shorted ON</li> </ul>
BRK Rq Volt > DC Bus	Requested Output Voltage is 5% greater than the DC Bus Voltage	<ul style="list-style-type: none"> <li>• Incorrect Setting of Pick/Hold/Re-level Voltage in Adjustable Variables</li> <li>• Low Line Voltage</li> </ul>
Brk Test UTS/DTS Flt	Brake Test UTS/DTS Fault. The elevator hit the UTS limit running in the up direction or DTS limit running in the down direction during a brake test. The car will abort the brake test immediately if it is approaching or hits a terminal limit.	<ul style="list-style-type: none"> <li>• Test run in the direction of the terminal floor.</li> <li>• UTS or DTS input failed or turned off unexpectedly during the test. Try to run the test again while monitoring the status of the UTS and DTS inputs.</li> <li>• UTS or DTS input off prior to starting the test. Check the status of the UTS and DTS inputs prior to the test and make sure that inputs work as expected.</li> <li>• Selector and/or limit not setup or adjusted properly.</li> </ul>

Fault	Description	Possible Cause/Suggested Fix
Brk Test Vel Time-out	Brake Test Velocity Time-out. The car has 6 seconds to reach within 10 fpm of the top speed parameter. (See the Top Speed parameter in the Car Motion menu). The test is aborted if the desired speed is not reached within the 6 second time period.	<ul style="list-style-type: none"> <li>• The car did not reach top speed during the test. Make sure the car can reach top speed during a normal run.</li> <li>• Make sure that the encoder velocity feedback is displaying the correct velocity.</li> <li>• If it is necessary to run the test before the car can run top speed, reduce the top speed parameter in the Car Motion menu to a speed value that the car can reach within 6 seconds.</li> <li>• For a high speed car, the speed profile parameters may need to be adjusted so that the car can reach top speed quickly.</li> </ul>
Buffer Switch Fault	Buffer Switch Open	<ul style="list-style-type: none"> <li>• Verify that the buffer switch is set and the switch is closed.</li> <li>• Faulty wiring on the buffer switch circuit.</li> <li>• Car hit the buffer</li> </ul>
Can Bus Off Error	Can Bus Off Error. The Can bus has been inactive for too long a period of time.	<ul style="list-style-type: none"> <li>• Faulty CAN bus wiring. Check the Can bus terminal connections on all boards.</li> </ul>
CAN spb bad command	Unintended Motion Command to Safety Processor unintentionally set	<ul style="list-style-type: none"> <li>• This fault should never occur. Contact GAL.</li> </ul>
Car 1 Comm Loss	The group car is not communicating with Car 1.	<ul style="list-style-type: none"> <li>• Faulty wiring from R/T+ and R/T- from car to car.</li> <li>• Faulty U6 driver chip on 1100 board.</li> <li>• Noise on shield wire. Connect shield only on one end.</li> <li>• Noise on the communication wires. Run wires in separate conduit.</li> </ul>
Car 2 Comm Loss	The group car is not communicating with Car 2.	<ul style="list-style-type: none"> <li>• Faulty wiring from R/T+ and R/T- from car to car.</li> <li>• Faulty U6 driver chip on 1100 board.</li> <li>• Noise on shield wire. Connect shield only on one end.</li> <li>• Noise on the communication wires. Run wires in separate conduit.</li> </ul>



Fault	Description	Possible Cause/Suggested Fix
Car 3 Comm Loss	The group car is not communicating with Car 3.	<ul style="list-style-type: none"> <li>• Faulty wiring from R/T+ and R/T- from car to car.</li> <li>• Faulty U6 driver chip on 1100 board.</li> <li>• Noise on shield wire. Connect shield only on one end.</li> <li>• Noise on the communication wires. Run wires in separate conduit.</li> </ul>
Car 4 Comm Loss	The group car is not communicating with Car 4.	<ul style="list-style-type: none"> <li>• Faulty wiring from R/T+ and R/T- from car to car.</li> <li>• Faulty U6 driver chip on 1100 board.</li> <li>• Noise on shield wire. Connect shield only on one end.</li> <li>• Noise on the communication wires. Run wires in separate conduit.</li> </ul>
Car 5 Comm Loss	The group car is not communicating with Car 5.	<ul style="list-style-type: none"> <li>• Faulty wiring from R/T+ and R/T- from car to car.</li> <li>• Faulty U6 driver chip on 1100 board.</li> <li>• Noise on shield wire. Connect shield only on one end.</li> <li>• Noise on the communication wires. Run wires in separate conduit.</li> </ul>
Car 6 Comm Loss	The group car is not communicating with Car 6	<ul style="list-style-type: none"> <li>• Faulty wiring from R/T+ and R/T- from car to car.</li> <li>• Faulty U6 driver chip on 1100 board.</li> <li>• Noise on shield wire. Connect shield only on one end.</li> <li>• Noise on the communication wires. Run wires in separate conduit.</li> </ul>
Car 7 Comm Loss	The group car is not communicating with Car 7	<ul style="list-style-type: none"> <li>• Faulty wiring from R/T+ and R/T- from car to car.</li> <li>• Faulty U6 driver chip on 1100 board.</li> <li>• Noise on shield wire. Connect shield only on one end.</li> <li>• Noise on the communication wires. Run wires in separate conduit.</li> </ul>
Car 8 Comm Loss	The group car is not communicating with Car 8	<ul style="list-style-type: none"> <li>• Faulty wiring from R/T+ and R/T- from car to car.</li> <li>• Faulty U6 driver chip on 1100 board.</li> <li>• Noise on shield wire. Connect shield only on one end.</li> <li>• Noise on the communication wires. Run wires in separate conduit.</li> </ul>

Fault	Description	Possible Cause/Suggested Fix
Car Call Light Fuse	Car Call Light Fuse Blown	<ul style="list-style-type: none"> <li>• Check for short on the Car Call Light circuit.</li> </ul>
Car Call Power Fuse	Car Call Power Fuse Blown	<ul style="list-style-type: none"> <li>• Check for short on Car Call Power circuit.</li> </ul>
Car Com Device Reset	Serial Car board reset unexpectedly. Usually caused by loss of power to the individual board.	<ul style="list-style-type: none"> <li>• Usually caused by loss of power to the individual board. Check for loose connection on power to board.</li> <li>• Faulty I/O board.</li> </ul>
Car Gate Safe Fault	Car Gate safe fault	<ul style="list-style-type: none"> <li>• After Controller was safe with doors, gate switch and locks made and ready to run, a Gate switch (front or rear) input turned OFF.</li> </ul>
Car Overspeed > 125%	Car Overspeed Greater than 125 percent of contract speed. This fault sets the gripper or emergency brake.	<ul style="list-style-type: none"> <li>• Encoder PPR incorrectly set. Set to match the Drive's Encoder Pulses.</li> <li>• Encoder RPM incorrectly set. Set to match the Motor or Governor RPM (depends on controller speed feedback).</li> <li>• The drive is not controlling the hoist machine motor. Check the response setting on the drive.</li> </ul>
Car Safe Fault	The Car Safe Fault occurs from the wanting to run but does not have a critical input energized. Some of the conditions for a car safe fault will also cause other faults to be logged.	<ul style="list-style-type: none"> <li>• The car does not have the gate or lock inputs and is running or trying to run</li> <li>• The gripper GTS input is not on.</li> <li>• The stop switch is open</li> <li>• An inspection string input fault. Only one input should be on in the inspection string (AUTO, CTI, ICI, ACC or MRI)</li> <li>• Gate or Lock Bypass switch is on when not on car top inspection</li> </ul>
Car Safe Fault Preop	The car had a car safe fault while pre-opening the door.	<ul style="list-style-type: none"> <li>• The car lost the DZ input while leveling into the floor and the door was open.</li> </ul>

Fault	Description	Possible Cause/Suggested Fix
Car Safe Fault Start	The car had an onward call, had the door close limit but the car gate or door locks did not make after a 3 second time-out.	<ul style="list-style-type: none"> <li>• The locks are not making properly when the door closes.</li> <li>• The door is not closing properly.</li> </ul>
Car Safety Sw. Fault	Car Safety Switch Fault	<ul style="list-style-type: none"> <li>• Verify that the car safety is not tripped.</li> <li>• Faulty wiring in the car safety circuit</li> </ul>
Car Top Stop Switch	Car top stop switch	<ul style="list-style-type: none"> <li>• Safety String Fault. Refer to Safety String Page on Diagrams. Check/replace input Chip.</li> </ul>
CCB FET Open Blue	Car Call Board FET open blue	<ul style="list-style-type: none"> <li>• Faulty LED signal from RGB Board. Look at detailed car faults log to determine device. 'dev' gives you address for global CAN device, 'dv2' gives you local CAN device and 'pf1' the number for the IO location within the local board.</li> </ul>
CCB FET Open Green	Car Call Board FET open green	<ul style="list-style-type: none"> <li>• Faulty LED signal from RGB Board. Look at detailed car faults log to determine device. 'dev' gives you address for global CAN device, 'dv2' gives you local CAN device and 'pf1' the number for the IO location within the local board.</li> </ul>
CCB FET Open Red	Car Call Board FET open red	<ul style="list-style-type: none"> <li>• Faulty LED signal from RGB Board. Look at detailed car faults log to determine device. 'dev' gives you address for global CAN device, 'dv2' gives you local CAN device and 'pf1' the number for the IO location within the local board.</li> </ul>
CCB FET Short Blue	Car Call Board FET short blue	<ul style="list-style-type: none"> <li>• Faulty LED signal from RGB Board. Look at detailed car faults log to determine device. 'dev' gives you address for global CAN device, 'dv2' gives you local CAN device and 'pf1' the number for the IO location within the local board.</li> </ul>

Fault	Description	Possible Cause/Suggested Fix
CCB FET Short Green	Car Call Board FET short green	<ul style="list-style-type: none"> <li>Faulty LED signal from RGB Board. Look at detailed car faults log to determine device. 'dev' gives you address for global CAN device, 'dv2' gives you local CAN device and 'pf1' the number for the IO location within the local board.</li> </ul>
CCB FET Short Red	Car Call Board FET short red	<ul style="list-style-type: none"> <li>Faulty LED signal from RGB Board. Look at detailed car faults log to determine device. 'dev' gives you address for global CAN device, 'dv2' gives you local CAN device and 'pf1' the number for the IO location within the local board.</li> </ul>
CCB LED Open Blue	Car Call Board LED open blue	<ul style="list-style-type: none"> <li>Faulty LED signal from RGB Board. Look at detailed car faults log to determine device. 'dev' gives you address for global CAN device, 'dv2' gives you local CAN device and 'pf1' the number for the IO location within the local board.</li> </ul>
CCB LED Open Green	Car Call Board LED open green	<ul style="list-style-type: none"> <li>Faulty LED signal from RGB Board. Look at detailed car faults log to determine device. 'dev' gives you address for global CAN device, 'dv2' gives you local CAN device and 'pf1' the number for the IO location within the local board.</li> </ul>
CCB LED Open Red	Car Call Board LED open red	<ul style="list-style-type: none"> <li>Faulty LED signal from RGB Board. Look at detailed car faults log to determine device. 'dev' gives you address for global CAN device, 'dv2' gives you local CAN device and 'pf1' the number for the IO location within the local board.</li> </ul>
CCB LED Short Blue	Car Call Board LED short blue	<ul style="list-style-type: none"> <li>Faulty LED signal from RGB Board. Look at detailed car faults log to determine device. 'dev' gives you address for global CAN device, 'dv2' gives you local CAN device and 'pf1' the number for the IO location within the local board.</li> </ul>

Fault	Description	Possible Cause/Suggested Fix
CCB LED Short Green	Car Call Board LED short green	<ul style="list-style-type: none"> <li>Faulty LED signal from RGB Board. Look at detailed car faults log to determine device. 'dev' gives you address for global CAN device, 'dv2' gives you local CAN device and 'pf1' the number for the IO location within the local board.</li> </ul>
CCB LED Short Red	Car Call Board LED short red	<ul style="list-style-type: none"> <li>Faulty LED signal from RGB Board. Look at detailed car faults log to determine device. 'dev' gives you address for global CAN device, 'dv2' gives you local CAN device and 'pf1' the number for the IO location within the local board.</li> </ul>
CCB No Comm Aux Bd 1	Car Call Board local aux board 1 comm loss	<ul style="list-style-type: none"> <li>Comm loss to RGB Auxiliary Car Call Board. Check wiring and bus termination jumpers on boards. If problem persists, check Car Comm Status under diagnostics.</li> </ul>
CCB No Comm Aux Bd 2	Car Call Board local aux board 2 comm loss	<ul style="list-style-type: none"> <li>Comm loss to RGB Auxiliary Car Call Board. Check wiring and bus termination jumpers on boards. If problem persists, check Car Comm Status under diagnostics.</li> </ul>
CCB No Comm Board 1	Car Call Board local board 1 comm loss	<ul style="list-style-type: none"> <li>Comm loss to RGB Car Call Board. Check wiring and bus termination jumpers on boards. If problem persists, check Car Comm Status under diagnostics.</li> </ul>
CCB No Comm Board 2	Car Call Board local board 2 comm loss	<ul style="list-style-type: none"> <li>Comm loss to RGB Car Call Board. Check wiring and bus termination jumpers on boards. If problem persists, check Car Comm Status under diagnostics.</li> </ul>
CCB No LED Board	Car Call LED board missing	<ul style="list-style-type: none"> <li>Faulty LED signal from RGB Board. Look at detailed car faults log to determine device. 'dev' gives you address for global CAN device, 'dv2' gives you local CAN device and 'pf1' the number for the IO location within the local board.</li> </ul>

Fault	Description	Possible Cause/Suggested Fix
CCB Stuck Button	Car Call Board stuck button	<ul style="list-style-type: none"> <li>• Faulty LED signal from RGB Board. Look at detailed car faults log to determine device. 'dev' gives you address for global CAN device, 'dv2' gives you local CAN device and 'pf1' the number for the IO location within the local board.</li> </ul>
Comm Fault (From SEL)	Selector not communicating to the main CPU.	<ul style="list-style-type: none"> <li>• Faulty Can communication wire connection. Verify proper twisted pair wires to the CANH and CANL terminals on the board.</li> <li>• Noise on the Can bus. Verify that the shield wire is connected according to the job print.</li> </ul> <p><b>See: SEL Dev CAN Fault</b></p>
Comm Fault (From SPB)	Safety Processor not communicating to the main CPU.	<ul style="list-style-type: none"> <li>• Faulty Can communication wire connection. Verify proper twisted pair wires to the CANH and CANL terminals on the board.</li> <li>• Noise on the Can bus. Verify that the shield wire is connected according to the job print.</li> </ul> <p><b>See: SPB Dev CAN Fault</b></p>
Comp. Switch Fault	Compensating Rope Switch Open	<ul style="list-style-type: none"> <li>• Verify that the compensating rope switch is set and the switch is closed.</li> <li>• Improper cabling of the compensating ropes on the sheave.</li> </ul>
COP CAN Com Error	COP Board Can Communication Error.	<ul style="list-style-type: none"> <li>• Faulty Can communication wire connection. Verify proper twisted pair wires to the CANH and CANL terminals on the COP board.</li> <li>• Noise on the Can bus. Verify that the shield wire is connected according to the job print.</li> </ul>
CTCAN Device Fault	Device on the Car Top CAN Port has a Fault	<ul style="list-style-type: none"> <li>• Look at the details of the fault. The device name and the error code that caused the fault are listed.</li> <li>• Look up the fault code for the device for debugging information.</li> </ul>

Fault	Description	Possible Cause/Suggested Fix
CTCAN Device Reset	Device on the Car Top CAN Port has reset	<ul style="list-style-type: none"> <li>• Look at the details of the fault. The device name and the error code that caused the fault are listed.</li> <li>• The device requested an initialization packet from the main CPU. Typically this occurs during power up or from a power cycle of the individual device.</li> <li>• Ignore the error if the controller power has been cycled. Otherwise, check the device communications and power connections.</li> </ul>
CWT Sw Error at DT	Car 'above cwt' flag was set for above the counterweight when the car hit the down terminal slowdown limit.	<ul style="list-style-type: none"> <li>• The counterweight switch was not hit during the run or the car was lost when powered up.</li> <li>• Faulty wiring of the counterweight switch.</li> <li>• Improper adjustment of the counterweight switch.</li> </ul>
CWT Sw Error at UT	Car 'above cwt' flag was set for below the counterweight when the car hit the up terminal slowdown limit.	<ul style="list-style-type: none"> <li>• The counterweight switch was not hit during the run or the car was lost when powered up.</li> <li>• Faulty wiring of the counterweight switch.</li> <li>• Improper adjustment of the counterweight switch.</li> </ul>
DBR Temperature Flt	Dynamic Braking Resistor Temperature Fault. The temperature for the dynamic braking resistors is read in through a temperature sensor mounted above the resistors. When the temperature sensor opens a contact, the CPU detects a temperature fault, an error is recorded, the car is shut down at the next floor and the DBC relay is de energized to open the DB Resistor circuit.	<ul style="list-style-type: none"> <li>• Faulty Temperature Sensor. If the DB Resistors are not hot, check the temperature sensor input board connected to the CPU board. The input LED should be on when the temperature is okay. If the LED is not on, jump the two terminals on the temperature input board and the LED should go on. If the LED goes on then the Temperature Sensor is bad. Replace the Temperature Sensor.</li> <li>• Faulty Temperature Sensor Input Board. Test the sensor input as above. If the LED does not turn on when the input terminals are jumped together, replace the Temperature Sensor Input Board.</li> </ul>

Fault	Description	Possible Cause/Suggested Fix
Delta off Fault	DEL input did not come on at start or went off during a run.	<ul style="list-style-type: none"> <li>• The delta contact did not make on a Y-Delta starter.</li> <li>• The MC contact did not make on an across-the-line starter</li> <li>• The 'at speed' contact did not make on an electronic soft-starter.</li> <li>• Faulty DEL input. Replace the DEL input chip.</li> </ul>
Delta On Fault	DEL input failed on when is should have been off. This would occur at the start of a run when the I/O's are checked. The input failed on or the contact for the input failed closed.	<ul style="list-style-type: none"> <li>• Faulty DEL input (failed on). Check the input and output status on the LCD interface.</li> <li>• Faulty contact for DEL input failed on. Replace the DEL input chip.</li> </ul>
DF I/O Failed Off	The DF input or output has failed off	<p><b>Hydro</b></p> <ul style="list-style-type: none"> <li>• Fault on Safety Processor Board. The Safety Processor Board can disable the run control to the SDF output chip. Check if the PIC or PAL inhibit LED turns on when the car attempts to run. Check the elevator service, faults, and inputs/outputs on the Safety Processor Board LCD display.</li> <li>• Faulty wiring to the SC common on the MAIN I/O board.</li> <li>• Faulty wiring to the SDF terminal on the MAIN I/O board.</li> <li>• Faulty wiring to the Down Fast valve.</li> <li>• Faulty SDFi input (replace input chip).</li> <li>• Faulty SDF output (replace output chip).</li> </ul>
DF I/O Failed On	The DF input or output has failed on.	<p><b>Hydro</b></p> <ul style="list-style-type: none"> <li>• Faulty SDFi input (replace input chip).</li> <li>• Faulty SDF output (replace output chip).</li> </ul>
DL Failed On Fault	DL Failed On Fault. The DL leveling sensor did not turn off during a run.	<ul style="list-style-type: none"> <li>• DL hall effect sensor bad on selector sensor board. Replace sensor board.</li> <li>• DL input on selector driver board is bad. Replace selector driver board.</li> </ul>



Fault	Description	Possible Cause/Suggested Fix
DL/GS Fault	Safety Processor Door Lock/Gate Switch Fault	<ul style="list-style-type: none"> <li>• Car is moving outside the door zone with the door open. The car will immediately shut down.</li> </ul> <b>See: SPB DL/GS Fault</b>
DL20 Phone Test Failed	Phone Test from DL20 phone monitoring device indicated a failure	<ul style="list-style-type: none"> <li>• Refer to the manufacturers troubleshooting guide for the DL20.</li> </ul>
DLB & DLB-1 Opposite	Input failure on one of the Door Lock Bottom (DLB) inputs.	<ul style="list-style-type: none"> <li>• Faulty DLB or DLB-1 input (replace input chip).</li> </ul>
DLB open w/R Acc DLT	Door Lock Bottom open with Rear Access Door Lock Top is open at the top floor.	<ul style="list-style-type: none"> <li>• Incorrect door lock wiring. Wire according to the job schematic.</li> <li>• If access is enabled, verify that the correct lock is wired for the front or rear door that will open on access.</li> </ul>
DLB open with DLM	Door Lock Bottom is open while the Door Lock Middle is open at a middle floor.	<ul style="list-style-type: none"> <li>• Incorrect door lock wiring. Wire according to the job schematic.</li> <li>• If access is enabled, verify that the correct lock is wired for the front or rear door that will open on access.</li> </ul>
DLB open with DLT	Door Lock Bottom is open while the Door Lock Top is open at a top floor.	<ul style="list-style-type: none"> <li>• Incorrect door lock wiring. Wire according to the job schematic.</li> <li>• If access is enabled, verify that the correct lock is wired for the front or rear door that will open on access.</li> </ul>
DLB open with RLM	Door Lock Bottom is open while the Rear Door Lock Middle is open at a middle floor.	<ul style="list-style-type: none"> <li>• Incorrect door lock wiring. Wire according to the job schematic.</li> <li>• If access is enabled, verify that the correct lock is wired for the front or rear door that will open on access.</li> </ul>
DLM & DLM-1 Opposite	Input failure on one of the Door Lock Middle (DLM) inputs.	<ul style="list-style-type: none"> <li>• Faulty DLM or DLM-1 input (replace input chip).</li> </ul>

Fault	Description	Possible Cause/Suggested Fix
DLM open with DLB	Door Lock Middle is open while the Door Lock Bottom is open at a bottom floor.	<ul style="list-style-type: none"> <li>• Incorrect door lock wiring. Wire according to the job schematic.</li> <li>• If access is enabled, verify that the correct lock is wired for the front or rear door that will open on access.</li> </ul>
DLM open with DLT	Door Lock Middle is open while the Door Lock Top is open at a top floor.	<ul style="list-style-type: none"> <li>• Incorrect door lock wiring. Wire according to the job schematic.</li> <li>• If access is enabled, verify that the correct lock is wired for the front or rear door that will open on access.</li> </ul>
DLT & DLT-1 Opposite	Input failure on one of the Door Lock Top (DLT) inputs.	<ul style="list-style-type: none"> <li>• Faulty DLT or DLT-1 input (replace input chip).</li> </ul>
DLT open w/R Acc DLB	Door Lock Top open with Rear Access Door Lock Bottom is open at the bottom floor.	<ul style="list-style-type: none"> <li>• Incorrect door lock wiring. Wire according to the job schematic.</li> <li>• If access is enabled, verify that the correct lock is wired for the front or rear door that will open on access.</li> </ul>
DLT open with DLB	Door Lock Top is open while the Door Lock Bottom is open at a bottom floor.	<ul style="list-style-type: none"> <li>• Incorrect door lock wiring. Wire according to the job schematic.</li> <li>• If access is enabled, verify that the correct lock is wired for the front or rear door that will open on access.</li> </ul>
DLT open with DLM	Door Lock Top is open while the Door Lock Middle is open at a middle floor.	<ul style="list-style-type: none"> <li>• Incorrect door lock wiring. Wire according to the job schematic.</li> <li>• If access is enabled, verify that the correct lock is wired for the front or rear door that will open on access.</li> </ul>
DLT open with RLM	Door Lock Top is open while the Rear Door Lock Middle is open at a middle floor.	<ul style="list-style-type: none"> <li>• Incorrect door lock wiring. Wire according to the job schematic.</li> <li>• If access is enabled, verify that the correct lock is wired for the front or rear door that will open on access.</li> </ul>

Fault	Description	Possible Cause/Suggested Fix
Dn Directional Fault	Car unexpectedly hit the Down Normal Limit while running down.	<ul style="list-style-type: none"> <li>• Faulty wiring for the DN limit.</li> <li>• <b>Tape Selector:</b> Incorrect placement of DT magnet (too close to center of tape).</li> <li>• <b>Tapeless Selector:</b> Incorrect placement of DT magnet not aligned properly with magnetic sensor on selector (cross talk from DT magnet to DN sensor).</li> </ul>
Dn Normal SW Setup	Down Normal must be on before reaching bottom floor dead level	<ul style="list-style-type: none"> <li>• The down normal needs to be moved down so when the car is Dead level at the bottom landing DN is ON. Allow at least 2 inches run before DN turns OFF</li> </ul>
DN Pulse Fault	Selector pulsed the DN latch multiple times but the DN state was not latched	<ul style="list-style-type: none"> <li>• Memory of the DN sensor is stored on a state saver latch device. Replace the Selector Board.</li> </ul> <p><b>See: SEL DN Pulse Fault</b></p>
DNR I/O Failed Off	The DNR input or output has failed off.	<ul style="list-style-type: none"> <li>• Fault on Safety Processor. The Safety Processor is located on the MAIN I/O board. This device can disable the run control to the DNR output chip. Check if the SAF-PROC or SAF-PAL FAULT LEDs turn on when the car attempts to run. Check the elevator service, faults, and inputs/outputs on the Safety Processor status of the LCD Display Interface.</li> <li>• Faulty DNR output or DNRi input. Replace the DNR output and DNRi input chip.</li> <li>• No 24VDC from the drive. Refer to Schematics.</li> <li>• Incorrect jumper placement on MAIN I/O board. Verify that jumpers on the bottom center of the board are positioned correctly for SOURCE or SINK. The jumpers depend on the drive type and is shown on the drive portion of the job schematic. If necessary move the jumpers to the correct position.</li> <li>• RUN, MC or BRK auxiliary contact not making properly. Verify the operation and contact integrity.</li> </ul>

Fault	Description	Possible Cause/Suggested Fix
DNR I/O Failed On	The DNR input or output has failed on.	<ul style="list-style-type: none"> <li>• Faulty DNR output. Replace the DNR output chip.</li> <li>• Faulty DNRi input. Replace DNRi input chip.</li> <li>• Incorrect jumper placement on MAIN I/O board. Verify that jumpers on the bottom center of the board are positioned correctly for SOURCE or SINK. The jumpers depend on the drive type and is shown on the drive portion of the job schematic. If necessary move the jumpers to the correct position.</li> </ul>
DON I/O Failed Off	The DON input or the drive run relay contact has failed off. The run relay on the drive turns on the DON input (Drive ON) indicating that the regulator is released and the drive is controlling the motor.	<ul style="list-style-type: none"> <li>• Loss of voltage on terminal SFC.</li> <li>• MC contact in series with the drive run relay opened. See MCX Off Fault for additional information.</li> <li>• The drive faulted on start and dropped the run relay. Check the drive fault log.</li> <li>• Faulty DRO relay controlled by the drive.</li> <li>• Faulty DON input on the controller. Replace the DON input chip.</li> <li>• The run relay in the drive is not programmed properly. Check the default drive setup for the run relay output.</li> </ul>
DON I/O Failed On	The DON input or the drive output has failed on. When the drive is turned off, the run relay on the drive will drop out turning off DON.	<ul style="list-style-type: none"> <li>• Improper wiring of the Drive On contact controlled by the drive.. Refer to prints for wire connections.</li> <li>• Faulty wiring to the DON input.</li> <li>• Faulty DON input on the controller. Replace the DON input chip.</li> <li>• Faulty DRO relay failed on.</li> <li>• The control of the DRO relay by the drive is not programmed properly. Check the default drive setup for the Drive On output.</li> </ul>
Door Close Fault	The door did not reach the Door Close Limit within the door close protection time.	<ul style="list-style-type: none"> <li>• Door Close Limit (DCL) not adjusted properly.</li> <li>• Faulty Door Close Limit (DCL). Replace DCL input chip.</li> <li>• Trash in door track preventing door from closing.</li> </ul>
Door Lock Safe Fault	Door lock safe fault	<ul style="list-style-type: none"> <li>• After Controller was safe with doors, gate switch and locks made and ready to run, a door lock input turned OFF.</li> </ul>

Fault	Description	Possible Cause/Suggested Fix
Door Low Voltage Flt	Door Line Voltage Low	<ul style="list-style-type: none"> <li>• Voltage Sensor Board Related. Voltage being monitored for Door Operator dropped below the setting for parameter 'Low Door Volt '</li> </ul>
Door Motor Overload	Door Motor Overload	<ul style="list-style-type: none"> <li>• Door Motor Overload signal tripped. Check Input chip for DMO signal</li> </ul>
Door Open Fault	The door did not reach the Door Open Limit within the door open protection time.	<ul style="list-style-type: none"> <li>• Door Open Limit (DOL) not adjusted properly.</li> <li>• Faulty Door Open Limit (DOL). Replace DOL input chip.</li> </ul>
Door Zone Aux On Flt	The auxiliary door zone input failed on.	<ul style="list-style-type: none"> <li>• One or both of the DZA sensors on the selector sensor board failed. Replace selector sensor board.</li> <li>• Faulty selector board. Replace the selector board.</li> </ul>
Door Zone Off Fault	Door Zone Fault occurs from the following conditions: <ul style="list-style-type: none"> <li>• The car is not on UL or DL when expected.</li> <li>• The car does not have DZ when expected.</li> <li>• The DZ relay does not drop out while in motion.</li> </ul>	The car does not have DZ when it is expected to be level at the floor. DZ output on selector board failed on or did not turn on. (Replace DZ output on selector driver board). One or both of the DZ sensors on the selector sensor board failed. Replace selector sensor board. <ul style="list-style-type: none"> <li>• DZ input on the GALX-1102 board failed on or off. Replace DZ input on the GALX-1102 board.</li> </ul>
Door Zone On Fault	The door zone input failed on.	<ul style="list-style-type: none"> <li>• DZ output on selector board did not turn off. (Replace DZ output on selector driver board).</li> <li>• One or both of the DZ sensors on the selector sensor board failed. Replace selector sensor board.</li> <li>• DZ input on the GALX-1102 board failed. Replace DZ input on the GALX-1102 board.</li> </ul>
DoorZone Aux Off Flt	The auxiliary door zone input failed off.	<ul style="list-style-type: none"> <li>• One or both of the DZA sensors on the selector sensor board failed. Replace selector sensor board.</li> <li>• Faulty Selector Driver Board. Replace the Selector Board</li> </ul>

Fault	Description	Possible Cause/Suggested Fix
DPM Input Fault	The DPM input fault occurs when door opens and the DPM input did not go off.	<ul style="list-style-type: none"> <li>• DPM switch not setup properly on the door operator.</li> <li>• Faulty DPM input. Replace DPM input chip.</li> </ul>
DPM Off/GS or DL On	<p>DPM Off with Gate Switch or Door Lock On.</p> <p>The Door Protection Module input must go on before gate switch or door lock inputs go on.</p>	<ul style="list-style-type: none"> <li>• The DPM switch on the door operator is not setup properly. DPM should turn on before the Gate Switch is made.</li> <li>• There is no DPM input on the door operator. Jump the DPM input to the GS-1 terminal.</li> <li>• Fault DPM input. Replace the DPM input chip.</li> </ul>
Drive Com Rcv Error	Controller has a communications error with drive. The controller has not received a valid message from the drive for more than one second.	<ul style="list-style-type: none"> <li>• Faulty communications cable connection. Check the drive twisted pairs connected from the drive to the 1100 CPU board.</li> <li>• Noise on the communication cable. Verify that the shield on the communications cable to the drive is connected to earth ground on one end.</li> <li>• Open the DB9 connector to the drive and verify that the wires are soldered properly.</li> <li>• Faulty communication chip. Replace the 1100 CPU board.</li> </ul>
Drive has Com Error	Drive has a communications error. The controller has received a message from the drive that it has communication receive errors.	<ul style="list-style-type: none"> <li>• Faulty communications cable connection. Check the drive twisted pairs connected from the drive to the 1100 CPU board.</li> <li>• Noise on the communication cable. Verify that the shield on the communications cable to the drive is connected to earth ground on one end.</li> <li>• Open the DB9 connector to the drive and verify that the wires are soldered properly.</li> <li>• Faulty communication chip. Replace the 1100 CPU board.</li> </ul>
Drive Ready Fault	The drive has a fault	<ul style="list-style-type: none"> <li>• The drive has or had a fault. Check the drive fault log.</li> <li>• Faulty RDY input. (Replace the RDY input).</li> <li>• Faulty Drive SFD relay. (Replace the SFD Relay).</li> <li>• Faulty Drive RDY relay. (Replace the RDY Relay).</li> </ul>

Fault	Description	Possible Cause/Suggested Fix
DT count Fault	The verification position count for the DT input switch was off by more than 10 inches when the switch was activated.	<ul style="list-style-type: none"> <li>• The car was lost due to a preset error. Check the guides on the selector. Check the fault log for binary preset errors.</li> <li>• The controller has a faulty encoder signal for the pulse count. Check that the car can make long runs without overshooting the floor or stopping short of the floor.</li> <li>• The power common to the limit switches was lost. Check fuse F1 on the selector board.</li> <li>• Incorrect counting of pulse counts. For <b>Tapeless</b>, check encoder connection to motor and encoder wiring. For <b>Tape</b>, check pulse sensors for proper quadrature at selector.</li> <li>• Hoistway not learned properly. Perform a hoistway learn procedure.</li> <li>• DT magnet not adjusted properly. Check at slow speed if sensor input is breaking, making and then breaking again. Magnet needs to be closer to the sensor on the selector.</li> </ul>
DT Failed On Fault	DT input Failed On Fault. The car was at the bottom floor and the DTS input was low (DTS switch made) but the DT input was high (DT not made).	<ul style="list-style-type: none"> <li>• The DTS limit is not installed. The DTS limit is used on all controllers as a verification that the car is at the bottom most landing. Add the DTS limit.</li> <li>• The DT did not break at the bottom terminal landing. Adjust or replace the DT switch.</li> <li>• Faulty DT input. Replace selector board.</li> <li>• Faulty DT sensor on selector sensor board. Replace the sensor board for tape selector or replace the individual DT sensor on tapeless selector.</li> </ul>
DT Limit Vel Fault	NTS Processor detected a car speed at the DT terminal limit that was greater than the clamp (parameter) speed	<ul style="list-style-type: none"> <li>• Verify that the limit activates at the correct location in the hoistway.</li> <li>• Verify the speed that the car hits the limit and adjust the limit velocity if necessary.</li> <li>• If the acceleration or deceleration rates were changed after the limit velocities were learned, the learn process may need to be repeated or the limit may need to be moved.</li> </ul> <p><b>See: NTS DT Limit Vel Flt</b></p>

Fault	Description	Possible Cause/Suggested Fix
DT Pulse Fault	Selector pulsed the DT latch multiple times but the DT state was not latched	<ul style="list-style-type: none"> <li>• Memory of the DT sensor is stored on a state saver latch device. Replace the Selector Board.</li> </ul> <b>See: SEL DT Pulse Fault</b>
DT Speed Fault	Car hit the DT Limit at a speed greater than the speed limit setting parameter.	<ul style="list-style-type: none"> <li>• Error previously set from the Safety Processor that is no long used. (See DT Limit Vel Fault).</li> </ul>
DT1 count Fault	The verification position count for the DT1 input switch was off by more than 10 inches when the switch was activated.	<ul style="list-style-type: none"> <li>• The car was lost due to a preset error. Check the guides on the selector. Check the fault log for binary preset errors.</li> <li>• The controller has a faulty encoder signal for the pulse count. Check that the car can make long runs without overshooting the floor or stopping short of the floor.</li> <li>• The power common to the limit switches was lost. Check fuse F1 on the selector board.</li> <li>• Incorrect counting of pulse counts. For <b>Tapeless</b>, check encoder connection to motor and encoder wiring. For <b>Tape</b>, check pulse sensors for proper quadrature at selector.</li> <li>• Hoistway not learned properly. Perform a hoistway learn procedure.</li> <li>• DT1 magnet not adjusted properly. Check at slow speed if sensor input is breaking, making and then breaking again. Magnet needs to be closer to the sensor on the selector.</li> </ul>
DT1 Limit Vel Fault	NTS Processor detected a car speed at the DT1 terminal limit that was greater than the clamp (parameter) speed	<ul style="list-style-type: none"> <li>• Verify that the limit activates at the correct location in the hoistway.</li> <li>• Verify the speed that the car hits the limit and adjust the limit velocity if necessary.</li> <li>• If the acceleration or deceleration rates were changed after the limit velocities were learned, the learn process may need to be repeated or the limit may need to be moved.</li> </ul> <b>See: NTS DT1 Limit Vel Flt</b>



Fault	Description	Possible Cause/Suggested Fix
DT2 count Fault	The verification position count for the DT2 input switch was off by more than 14 inches when the switch was activated.	<ul style="list-style-type: none"> <li>• The car was lost due to a preset error. Check the guides on the selector. Check the fault log for binary preset errors.</li> <li>• The controller has a faulty encoder signal for the pulse count. Check that the car can make long runs without overshooting the floor or stopping short of the floor.</li> <li>• The power common to the limit switches was lost. Check fuse F1 on the selector board.</li> <li>• Incorrect counting of pulse counts. For <b>Tapeless</b>, check encoder connection to motor and encoder wiring. For <b>Tape</b>, check pulse sensors for proper quadrature at selector.</li> <li>• Hoistway not learned properly. Perform a hoistway learn procedure.</li> <li>• DT2 magnet not adjusted properly. Check at slow speed if sensor input is breaking, making and then breaking again. Magnet needs to be closer to the sensor on the selector.</li> </ul>
DT2 Limit Vel Fault	NTS Processor detected a car speed at the DT2 terminal limit that was greater than the clamp (parameter) speed	<ul style="list-style-type: none"> <li>• Verify that the limit activates at the correct location in the hoistway.</li> <li>• Verify the speed that the car hits the limit and adjust the limit velocity if necessary.</li> <li>• If the acceleration or deceleration rates were change after the limit velocities were learned, the learn process may need to be repeated or the limit may need to be moved.</li> </ul> <p><b>See: NTS DT2 Limit Vel Flt</b></p>

Fault	Description	Possible Cause/Suggested Fix
DT3 count Fault	The verification position count for the DT3 input switch was off by more than 18 inches when the switch was activated.	<ul style="list-style-type: none"> <li>• The car was lost due to a preset error. Check the guides on the selector. Check the fault log for binary preset errors.</li> <li>• The controller has a faulty encoder signal for the pulse count. Check that the car can make long runs without overshooting the floor or stopping short of the floor.</li> <li>• The power common to the limit switches was lost. Check fuse F1 on the selector board.</li> <li>• Incorrect counting of pulse counts. For <b>Tapeless</b>, check encoder connection to motor and encoder wiring. For <b>Tape</b>, check pulse sensors for proper quadrature at selector.</li> <li>• Hoistway not learned properly. Perform a hoistway learn procedure.</li> <li>• DT3 magnet not adjusted properly. Check at slow speed if sensor input is breaking, making and then breaking again. Magnet needs to be closer to the sensor on the selector.</li> </ul>
DT3 Limit Vel Fault	NTS Processor detected a car speed at the DT3 terminal limit that was greater than the clamp (parameter) speed	<ul style="list-style-type: none"> <li>• Verify that the limit activates at the correct location in the hoistway.</li> <li>• Verify the speed that the car hits the limit and adjust the limit velocity if necessary.</li> <li>• If the acceleration or deceleration rates were changed after the limit velocities were learned, the learn process may need to be repeated or the limit may need to be moved.</li> </ul> <p><b>See: NTS DT3 Limit Vel Flt</b></p>

Fault	Description	Possible Cause/Suggested Fix
DT4 count Fault	The verification position count for the DT4 input switch was off by more than 24 inches when the switch was activated.	<ul style="list-style-type: none"> <li>• The car was lost due to a preset error. Check the guides on the selector. Check the fault log for binary preset errors.</li> <li>• The controller has a faulty encoder signal for the pulse count. Check that the car can make long runs without overshooting the floor or stopping short of the floor.</li> <li>• The power common to the limit switches was lost. Check fuse F1 on the selector board.</li> <li>• Incorrect counting of pulse counts. For <b>Tapeless</b>, check encoder connection to motor and encoder wiring. For <b>Tape</b>, check pulse sensors for proper quadrature at selector.</li> <li>• Hoistway not learned properly. Perform a hoistway learn procedure.</li> <li>• DT4 magnet not adjusted properly. Check at slow speed if sensor input is breaking, making and then breaking again. Magnet needs to be closer to the sensor on the selector.</li> </ul>
DT4 Limit Vel Fault	NTS Processor detected a car speed at the DT terminal limit that was greater than the clamp (parameter) speed	<ul style="list-style-type: none"> <li>• Verify that the limit activates at the correct location in the hoistway.</li> <li>• Verify the speed that the car hits the limit and adjust the limit velocity if necessary.</li> <li>• If the acceleration or deceleration rates were changed after the limit velocities were learned, the learn process may need to be repeated or the limit may need to be moved.</li> </ul> <p><b>See: NTS DT4 Limit Vel Flt</b></p>

Fault	Description	Possible Cause/Suggested Fix
DT5 count Fault	The verification position count for the DT5 input switch was off by more than 32 inches when the switch was activated.	<ul style="list-style-type: none"> <li>• The car was lost due to a preset error. Check the guides on the selector. Check the fault log for binary preset errors.</li> <li>• The controller has a faulty encoder signal for the pulse count. Check that the car can make long runs without overshooting the floor or stopping short of the floor.</li> <li>• The power common to the limit switches was lost. Check fuse F1 on the selector board.</li> <li>• Incorrect counting of pulse counts. For Tapeless, check encoder connection to motor and encoder wiring. For Tape, check pulse sensors for proper quadrature at selector.</li> <li>• Hoistway not learned properly. Perform a hoistway learn procedure.</li> <li>• DT5 magnet not adjusted properly. Check at slow speed if sensor input is breaking, making and then breaking again. Magnet needs to be closer to the sensor on the selector.</li> </ul>
DT5 Limit Vel Fault	NTS Processor detected a car speed at the DT5 terminal limit that was greater than the clamp (parameter) speed	<ul style="list-style-type: none"> <li>• Verify that the limit activates at the correct location in the hoistway.</li> <li>• Verify the speed that the car hits the limit and adjust the limit velocity if necessary.</li> <li>• If the acceleration or deceleration rates were changed after the limit velocities were learned, the learn process may need to be repeated or the limit may need to be moved.</li> </ul> <p><b>See: NTS DT5 Limit Vel Flt</b></p>

Fault	Description	Possible Cause/Suggested Fix
DT6 count Fault	The verification position count for the DT6 input switch was off by more than 42 inches when the switch was activated.	<ul style="list-style-type: none"> <li>• The car was lost due to a preset error. Check the guides on the selector. Check the fault log for binary preset errors.</li> <li>• The controller has a faulty encoder signal for the pulse count. Check that the car can make long runs without overshooting the floor or stopping short of the floor.</li> <li>• The power common to the limit switches was lost. Check fuse F1 on the selector board.</li> <li>• Incorrect counting of pulse counts. For <b>Tapeless</b>, check encoder connection to motor and encoder wiring. For <b>Tape</b>, check pulse sensors for proper quadrature at selector.</li> <li>• Hoistway not learned properly. Perform a hoistway learn procedure.</li> <li>• DT6 magnet not adjusted properly. Check at slow speed if sensor input is breaking, making and then breaking again. Magnet needs to be closer to the sensor on the selector.</li> </ul>
DT6 Limit Vel Fault	NTS Processor detected a car speed at the DT6 terminal limit that was greater than the clamp (parameter) speed	<ul style="list-style-type: none"> <li>• Verify that the limit activates at the correct location in the hoistway.</li> <li>• Verify the speed that the car hits the limit and adjust the limit velocity if necessary.</li> <li>• If the acceleration or deceleration rates were changed after the limit velocities were learned, the learn process may need to be repeated or the limit may need to be moved.</li> </ul> <p><b>See: NTS DT6 Limit Vel Flt</b></p>

Fault	Description	Possible Cause/Suggested Fix
DTS count Fault	Down Terminal Slowdown Limit Count Fault. The verification position count for the DTS input switch was off by more than 10 inches when the switch was activated.	<ul style="list-style-type: none"> <li>• The car was lost due to a preset error. Check the guides on the selector. Check the fault log for binary preset errors.</li> <li>• The controller has a faulty encoder signal for the pulse count. Check that the car can make long runs without overshooting the floor or stopping short of the floor.</li> <li>• The power common to the limit switches was lost. Check fuse F1 on the selector board.</li> <li>• Incorrect counting of pulse counts. For <b>Tapeless</b>, check encoder connection to motor and encoder wiring. For <b>Tape</b>, check pulse sensors for proper quadrature at selector.</li> <li>• Hoistway not learned properly. Perform a hoistway learn procedure.</li> <li>• DTS magnet not adjusted properly. Check at slow speed if sensor input is breaking, making and then breaking again. Magnet needs to be closer to the sensor on the selector.</li> </ul>
DTS Failed On Fault	DTS input Failed On Fault. The car was at the bottom floor and the DT input was low (DT switch made) but the DTS input was high (DTS not made).	<ul style="list-style-type: none"> <li>• The DT switch is not wired or DT input was lost. The state of DT is compared to that of DTS.</li> <li>• The DTS limit did not break at the bottom terminal landing. Adjust the DTS magnet.</li> <li>• Faulty DTS input. Replace the DTS input chip on the GALX-1102 board.</li> <li>• Faulty DTS sensor on selector sensor board. Replace the sensor board for tape selector or replace the individual DTS sensor on tapeless selector.</li> </ul>
DTS Speed Fault	Safety Processor detected a car speed at the DTS terminal limit that was greater than the clamp (parameter) speed	<ul style="list-style-type: none"> <li>• Verify that the limit activates at the correct location in the hoistway.</li> <li>• Verify the speed that the car hits the limit and adjust the limit velocity if necessary.</li> <li>• If the acceleration or deceleration rates were changed after the limit velocities were learned, the learn process may need to be repeated or the limit may need to be moved.</li> </ul>
EBAi Input Off Fault	Emergency brake test contacts in BA1,BA2 failed off	<ul style="list-style-type: none"> <li>• Possible bad NC contact on BA1 or BA2 relays</li> <li>• Check wiring on emergency brake relays</li> <li>• Replace EBAi input on expansion i/o board</li> </ul>

Fault	Description	Possible Cause/Suggested Fix
EBAi Input On Fault	Emergency brake test contacts in BA1,BA2 failed on	<ul style="list-style-type: none"> <li>• Make sure BA1 and BA2 relays are being cycled</li> <li>• Replace EBAi input on expansion i/o board</li> </ul>
EBBi Input Off Fault	Emergency brake test contacts in BB1,BB2 failed off	<ul style="list-style-type: none"> <li>• Possible bad NC contact on BB1 or BB2 relays</li> <li>• Check wiring on emergency brake relays</li> <li>• Replace EBBi input on expansion i/o board</li> </ul>
EBBi Input On Fault	Emergency brake test contacts in BB1,BB2 failed on	<ul style="list-style-type: none"> <li>• Make sure BB1 and BB2 relays are being cycled</li> <li>• Replace EBBi input on expansion i/o board</li> </ul>
EBK1 Input Failed OFF	Emergency Brake EBK1i failed off fault	<ul style="list-style-type: none"> <li>• Locate EBK1 and visually determine if output is turning ON and OFF Faulty EBK1i input chip. Replace the EBK1i input chip.</li> <li>• Faulty EBK1 output Chip. Replace the EBK1 output chip.</li> </ul>
EBK1 Input Failed ON	Emergency Brake EBK1 failed on fault	<ul style="list-style-type: none"> <li>• Locate EBK1 and visually determine if output is turning ON and OFF Faulty EBK1i input chip. Replace the EBK1i input chip.</li> <li>• Faulty EBK1 output Chip. Replace the EBK1 output chip.</li> </ul>
EBK2 Input Failed OFF	Emergency Brake EBK2 failed off fault	<ul style="list-style-type: none"> <li>• Locate EBK2 and visually determine if output is turning ON and OFF Faulty EBK2i input chip. Replace the EBK2i input chip.</li> <li>• Faulty EBK2 output Chip. Replace the EBK2 output chip.</li> </ul>
EBK2 Input Failed ON	Emergency Brake EBK2 failed on fault	<ul style="list-style-type: none"> <li>• Locate EBK2 and visually determine if output is turning ON and OFF Faulty EBK2i input chip. Replace the EBK2i input chip.</li> <li>• Faulty EBK1 output Chip. Replace the EBK2 output chip.</li> </ul>
EE Ram Failed	EE Ram (MRAM Memory) Fault. Valid magneto resistive memory is not found	<ul style="list-style-type: none"> <li>• Faulty 1100 CPU board. Replace 1100 CPU board</li> </ul>

Fault	Description	Possible Cause/Suggested Fix
EE Tst EE1 Failed OFF	Electric Eye Test. Freight door electric eye input EE1 failed off.	<ul style="list-style-type: none"> <li>• Verify that the electric eye input EE1 pulses on during the electric eye test.</li> <li>• Possible faulty electric eye device.</li> <li>• Possible faulty EE1 input - replace the input.</li> </ul>
EE Tst EE1 Failed ON	Electric Eye Test. Freight door electric eye input EE1 failed on.	<ul style="list-style-type: none"> <li>• Verify that the electric eye input EE1 is off before the electric eye test.</li> <li>• Possible faulty electric eye device.</li> <li>• Possible faulty EE1 input - replace the input.</li> </ul>
EE Tst EE2 Failed OFF	Electric Eye Test. Freight door electric eye input EE2 failed off.	<ul style="list-style-type: none"> <li>• Verify that the electric eye input EE2 pulses on during the electric eye test.</li> <li>• Possible faulty electric eye device.</li> <li>• Possible faulty EE2 input - replace the input.</li> </ul>
EE Tst EE2 Failed ON	Electric Eye Test. Freight door electric eye input EE2 failed on.	<ul style="list-style-type: none"> <li>• Verify that the electric eye input EE2 is off before the electric eye test.</li> <li>• Possible faulty electric eye device.</li> <li>• Possible faulty EE2 input - replace the input.</li> </ul>
EE Tst EER1 Faild OFF	Electric Eye Test. Freight rear door electric eye input EER1 failed off.	<ul style="list-style-type: none"> <li>• Verify that the electric eye input EER1 pulses on during the electric eye test.</li> <li>• Possible faulty electric eye device.</li> <li>• Possible faulty EER1 input - replace the input.</li> </ul>
EE Tst EER1 Faild ON	Electric Eye Test. Freight rear door electric eye input EER1 failed on.	<ul style="list-style-type: none"> <li>• Verify that the electric eye input EER1 is off before the electric eye test.</li> <li>• Possible faulty electric eye device.</li> <li>• Possible faulty EER1 input - replace the input.</li> </ul>
EE Tst EER2 Faild OFF	Electric Eye Test. Freight rear door electric eye input EER2 failed off.	<ul style="list-style-type: none"> <li>• Verify that the electric eye input EER2 pulses on during the electric eye test.</li> <li>• Possible faulty electric eye device.</li> <li>• Possible faulty EER2 input - replace the input.</li> </ul>
EE Tst EER2 Faild ON	Electric Eye Test. Freight rear door electric eye input EER2 failed on.	<ul style="list-style-type: none"> <li>• Verify that the electric eye input EER2 is off before the electric eye test.</li> <li>• Possible faulty electric eye device.</li> <li>• Possible faulty EER2 input - replace the input.</li> </ul>



Fault	Description	Possible Cause/Suggested Fix
EEprom Fault	Safety Processor EE Prom for device is not working properly	<ul style="list-style-type: none"> <li>• Defective EEprom device or EEprom device is not installed. The car will not be able to run until the EEprom is installed or replaced.</li> </ul> <p><b>See: SPB EEprom Fault</b></p>
EM Brake Input OFF	After the controller turns on the output EBKC, EBKi never went high.	<ul style="list-style-type: none"> <li>• Improper wiring of the brake EBRKC coil. Refer to prints for wire connections.</li> <li>• Faulty EBKi input. Replace EBKi input chip on i/o board.</li> <li>• Faulty EBKC output. Replace EBKC output chip on i/o board</li> </ul>
EM Brake Input ON	The EBKi input or EBKC output has failed on.	<ul style="list-style-type: none"> <li>• Improper wiring of the brake Emergency Brake coil. Refer to prints for wire connections.</li> <li>• Faulty EBKi input. Replace EBKi input chip on i/o board.</li> <li>• Faulty EBKC output. Replace EBKC output chip on i/o board.</li> </ul>
EM Brake Switch OFF	Emergency brake switch EBKS failed off once the car stopped	<ul style="list-style-type: none"> <li>• Improper wiring of Emergency brake switch.</li> <li>• Faulty EBKS input. Replace EBKS input chip on i/o board.</li> </ul>
EM Brake Switch ON	Emergency brake switch EBKS failed on once the car stopped	<ul style="list-style-type: none"> <li>• Improper wiring of Emergency brake switch.</li> <li>• Faulty EBKS input. Replace EBKS input chip on i/o board.</li> <li>• Check adjustment of Emergency brake switch.</li> </ul>
EM BRK CAN Com Error	Emergency Brake Board Can Communication Error.	<ul style="list-style-type: none"> <li>• Faulty CAN communication wire connection. Verify proper twisted pair wires to the CANH and CANL terminals on the brake board.</li> <li>• Noise on the CAN Bus. Verify that the shield wire is connected according to the job print.</li> </ul>
Emergency Brake Trip	Emergency Brake Trip fault	<ul style="list-style-type: none"> <li>• Controller may have detected car overspeed, unintended motion or lost governor input (GOV).</li> </ul>

Fault	Description	Possible Cause/Suggested Fix
Emrgncy Dispatch Flt	Controllers went into emergency Dispatch Operation	<ul style="list-style-type: none"> <li>• Loss of communication with the hall call boards</li> <li>• Loss of communication with the group</li> <li>• Losing the HCP input</li> </ul>
Enc Can Bus Ack Err	Encoder CAN Bus acknowledge error	<p>Can Open Encoder is not pulling the acknowledge line when data is being transmitted to it. Verify the following:</p> <ul style="list-style-type: none"> <li>• The Encoder is properly wired according to the schematic.</li> <li>• The Controller's encoder can baud rate matches that of the encoder.</li> <li>• Proper voltage is supplied to the encoder.</li> </ul>
Enc Can Bus Idle Err	Encoder CAN Bus idle	<p>Encoder CAN bus is floating for too many bit times so an idle bus is detected. Verify the following:</p> <ul style="list-style-type: none"> <li>• The Encoder is properly wired according to the schematic.</li> <li>• The Controller's encoder can baud rate matches that of the encoder.</li> <li>• Proper voltage is supplied to the encoder.</li> </ul>
Enc Can Bus Off Err	Encoder CAN Bus off	<p>Controller detected more than 255 transmit errors on CAN bus to the encoder. The CAN bus device is re-initialized to re-establish communications to the encoder. Verify the following:</p> <ul style="list-style-type: none"> <li>• The Encoder is properly wired according to the schematic.</li> <li>• The Controller's encoder can baud rate matches that of the encoder.</li> <li>• Proper voltage is supplied to the encoder.</li> </ul>
Enc Can Packet Fault	Encoder CAN Bus packet fault	<p>Can Open Encoder did not respond with the expected packet. This could be caused by noise on the encoder cable. Make sure the encoder cable is properly shielded.</p>
Encoder Battery Fault	Encoder battery has failed.	Not used on GALaxy IV

Fault	Description	Possible Cause/Suggested Fix
Encoder Busy Error	Encoder busy fault	<ul style="list-style-type: none"> <li>• Can Open Encoder appears as busy and it is not taking signals from controller. Check encoder to see if it failed. Check wiring and shield connections as well as voltage from the GALX-1100 CPU Board.</li> </ul>
Encoder Com Error	Encoder communication error. Encoder board detected Comm error while talking to the CAN Open encoder	<ul style="list-style-type: none"> <li>• Verify Connections on Encoder Board. Possible Noise on Encoder cable. Check Encoder Voltage. Check for wires shield connections on GALX-1100 CPU Board.</li> </ul>
Encoder Comm Fault	Safety Processor lost communications to the serial encoder.	Not used on GALaxy IV
Encoder Count Error	Encoder Count Error. An error is announced when the encoder count value is greater than 4 inches in 3 milliseconds.	<ul style="list-style-type: none"> <li>• Faulty encoder connection. Verify the encoder connection to the controller. The CAN Open Encoder connects directly to the GALX-1100 board on a tapeless system. On a tape system the encoder feedback connects to the GALX-1102 board and is routed to the GALX-1100 Board through a ribbon cable between the two boards. Verify the following:               <ul style="list-style-type: none"> <li>• The encoder device is wired properly and is properly shielded. Refer to the print for the proper connection.</li> <li>• The Controller's encoder can baud rate matches that of the encoder (tapeless selector).</li> <li>• Proper voltage is supplied to the encoder (tapeless selector).</li> <li>• The pulse signals from the tape selector read the correct voltage with the car running (2.9 volts at the controller).</li> <li>• The pulse sensors are mounted the correct distance from the tape (measure 5-7 volts at the sensor output on the selector board).</li> </ul> </li> </ul>
Encoder Count Fault	Pulse count out of range	Not used on GALaxy IV

Fault	Description	Possible Cause/Suggested Fix
Encoder Dir Fault	Encoder direction fault. Controller is in motion with an encoder velocity of more than 50 feet per minute and the direction in the encoder feedback is opposite to the direction run command. This fault sets the rope gripper or emergency brake. Disable this fault by setting Field Variable Enc Dir Flt Dis to 1=Disabled.	<ul style="list-style-type: none"> <li>• Check for proper Voltage on Encoder. Verify Connections on Encoder Board.</li> <li>• Possible Noise on Encoder cable.</li> <li>• Check for wires shield connections on encoder Isolation Board.</li> </ul>
Encoder Fault	Encoder Fault Detected	Not used on GALaxy IV
Encoder Init	Encoder initialization fault. Encoder board failed to initialize CAN open Encoder	<ul style="list-style-type: none"> <li>• Verify Connections on Encoder Board.</li> <li>• Possible Noise on Encoder cable. Check Encoder Voltage.</li> <li>• Check for wires shield connections on GALX-1100 CPU Board.</li> </ul>
Encoder Init Fault	Safety Processor cannot initialize encoder	Not used on GALaxy IV
Encoder PPR Error	PPR setting error from CAN Open encoder	<ul style="list-style-type: none"> <li>• Controller attempted to set PPR on the CAN Open Encoder but when we read it back, it did not change.</li> <li>• Possible Noise on Encoder cable. Check Encoder Voltage.</li> <li>• Check for wires shield connections on GALX-1100 CPU Board.</li> </ul>
Encoder Preset Flt	Encoder Preset error generated because controller could not stablish position from Can open encoder.	<ul style="list-style-type: none"> <li>• Can Open Encoder / Encoder Board lost track of car position.</li> <li>• Possible Noise on Encoder cable. Check Encoder Voltage.</li> <li>• Check for wires shield connections on GALX-1100 CPU Board.</li> </ul>

Fault	Description	Possible Cause/Suggested Fix
Encoder Velocity Fault	Encoder Communications packets not updated from encoder for 5 data transmissions.	Not used on GALaxy IV
EP Recall Car 1 OTS	Emergency Power Recall Car Out of Service Car 1	Car 1 was out of service while elevators were in an Emergency Power Recall Sequence • Check faults for car 1
EP Recall Car 2 OTS	Emergency Power Recall Car Out of Service Car 2	Car 2 was out of service while elevators were in an Emergency Power Recall Sequence • Check faults for car 2
EP Recall Car 3 OTS	Emergency Power Recall Car Out of Service Car 3	Car 3 was out of service while elevators were in an Emergency Power Recall Sequence • Check faults for car 3
EP Recall Car 4 OTS	Emergency Power Recall Car Out of Service Car 4	Car 4 was out of service while elevators were in an Emergency Power Recall Sequence • Check faults for car 4
EP Recall Car 5 OTS	Emergency Power Recall Car Out of Service Car 5	Car 5 was out of service while elevators were in an Emergency Power Recall Sequence • Check faults for car 5
EP Recall Car 6 OTS	Emergency Power Recall Car Out of Service Car 6	Car 6 was out of service while elevators were in an Emergency Power Recall Sequence • Check faults for car 6
EP Recall Car 7 OTS	Emergency Power Recall Car Out of Service Car 7	Car 7 was out of service while elevators were in an Emergency Power Recall Sequence • Check faults for car 7
EP Recall Car 8 OTS	Emergency Power Recall Car Out of Service Car 8	Car 8 was out of service while elevators were in an Emergency Power Recall Sequence • Check faults for car 8

Fault	Description	Possible Cause/Suggested Fix
EPR Pwr Lost Moving	EP Recovery power lost while moving	<ul style="list-style-type: none"> <li>• Controller failed to turn on Normal Power Drive and Emergency Power Drive outputs (NPD and EPD) while in motion. Condition should not occur.</li> </ul>
EPRrecall Car1 Tim-ot	Emergency Power Recall Time-out Car 1	<ul style="list-style-type: none"> <li>• Car 1 timeout while it was in Emergency power recall mode Make sure the field variable 'Recall Timeout' is set properly to allow the car enough time to recover if it is between floors and away from Emergency Power Floor If you have a blank shaft, consider increasing the Recovery Speed (default 25fpm)</li> </ul>
EPRrecall Car2 Tim-ot	Emergency Power Recall Time-out Car 2	<ul style="list-style-type: none"> <li>• Car 2 timeout while it was in Emergency power recall mode Make sure the field variable 'Recall Timeout' is set properly to allow the car enough time to recover if it is between floors and away from Emergency Power Floor If you have a blank shaft, consider increasing the Recovery Speed (default 25fpm)</li> </ul>
EPRrecall Car3 Tim-ot	Emergency Power Recall Time-out Car 3	<ul style="list-style-type: none"> <li>• Car 3 timeout while it was in Emergency power recall mode Make sure the field variable 'Recall Timeout' is set properly to allow the car enough time to recover if it is between floors and away from Emergency Power Floor If you have a blank shaft, consider increasing the Recovery Speed (default 25fpm)</li> </ul>
EPRrecall Car4 Tim-ot	Emergency Power Recall Time-out Car 4	<ul style="list-style-type: none"> <li>• Car 4 timeout while it was in Emergency power recall mode Make sure the field variable 'Recall Timeout' is set properly to allow the car enough time to recover if it is between floors and away from Emergency Power Floor If you have a blank shaft, consider increasing the Recovery Speed (default 25fpm)</li> </ul>

Fault	Description	Possible Cause/Suggested Fix
EPRrecall Car5 Tim-ot	Emergency Power Recall Time-out Car 5	<ul style="list-style-type: none"> <li>• Car 5 timeout while it was in Emergency power recall mode</li> </ul> Make sure the field variable 'Recall Timeout' is set properly to allow the car enough time to recover if it is between floors and away from Emergency Power Floor If you have a blank shaft, consider increasing the Recovery Speed (default 25fpm)
EPRrecall Car6 Tim-ot	Emergency Power Recall Time-out Car 6	<ul style="list-style-type: none"> <li>• Car 6 timeout while it was in Emergency power recall mode</li> </ul> Make sure the field variable 'Recall Timeout' is set properly to allow the car enough time to recover if it is between floors and away from Emergency Power Floor If you have a blank shaft, consider increasing the Recovery Speed (default 25fpm)
EPRrecall Car7 Tim-ot	Emergency Power Recall Time-out Car 7	<ul style="list-style-type: none"> <li>• Car 7 timeout while it was in Emergency power recall mode</li> </ul> Make sure the field variable 'Recall Timeout' is set properly to allow the car enough time to recover if it is between floors and away from Emergency Power Floor If you have a blank shaft, consider increasing the Recovery Speed (default 25fpm)
EPRrecall Car8 Tim-ot	Emergency Power Recall Time-out Car 8	<ul style="list-style-type: none"> <li>• Car 8 timeout while it was in Emergency power recall mode</li> </ul> Make sure the field variable 'Recall Timeout' is set properly to allow the car enough time to recover if it is between floors and away from Emergency Power Floor If you have a blank shaft, consider increasing the Recovery Speed (default 25fpm)

Fault	Description	Possible Cause/Suggested Fix
EQ Ctwt Derailment	<p>Earthquake Counterweight Derailment. The counterweight derailment mechanism has activated. This is usually from a ring and string: when the ring and string touch, the ROS relay coil voltage is shorted to EGND causing the relay to drop and the COL input to turn on from the NC contact on ROS. The seismic condition must be cleared and the controller seismic operation must be manually reset.</p>	<ul style="list-style-type: none"> <li>• Check that the counterweight frame is properly held in between the counterweight rails by the counterweight roller guides or slide shoes. Correct as required.</li> <li>• Check the position of the ring and string to verify that they are not accidentally touching. Correct as required.</li> <li>• Check that the Earthquake Board has 24VDC power.</li> <li>• Verify that the ROS relay is picked when the board is properly powered.</li> <li>• The COL input possibly failed on. Replace the input.</li> </ul>
EQ Seismic Active	<p>Earthquake Seismic Switch. The earthquake seismic switch has activated. The seismic condition must be cleared and the controller seismic operation manually reset.</p>	<ul style="list-style-type: none"> <li>• Check the seismic detection device for active seismic output.</li> <li>• The ETH input possibly failed on. Replace the input.</li> </ul>



Fault	Description	Possible Cause/Suggested Fix
Estop Fault	An emergency stop occurred while moving or attempting to move.	<p>The 'P' input did not drop from MC, BRK or RUN contactors being energized.</p> <ul style="list-style-type: none"> <li>• The drive on (DON) input did not energize or dropped out while running.</li> <li>• The BRK contactor did not energize or dropped out while running.</li> <li>• BRKI input did not turn on or dropped out while running.</li> <li>• The MCX contactor did not energize or dropped out while running</li> <li>• The MCX input did not turn on or dropped out while running.</li> <li>• The stop switch was pulled while running.</li> <li>• The car was not safe usually from clipping a door lock. See Car Safe Fault.</li> <li>• The stall protection timer timed-out.</li> </ul> <p><b>(Hydro only)</b> An emergency power recall was initiated while the car was running up.</p> <ul style="list-style-type: none"> <li>• The pulse count stopped counting</li> </ul>
ETS Dn Flt Set EBrk	Safety Processor detected a car speed at the ETS Down terminal limit that was greater than the clamp (parameter) speed. The Safety Processor will drop the Emergency Brake if the Reduced Stroke Buffer option is selected.	<ul style="list-style-type: none"> <li>• Verify that the limit activates at the correct location in the hoistway.</li> <li>• Verify the speed that the car hits the limit and adjust the limit velocity if necessary.</li> <li>• If the acceleration or deceleration rates were changed after the limit velocities were learned, the learn process may need to be repeated or the limit may need to be moved.</li> </ul> <p><b>See: SPB ETS Dn Flt Set EB</b></p>
ETS Down Speed Fault	Safety Processor detected a car speed at the ETS Down terminal limit that was greater than the clamp (parameter) speed	<ul style="list-style-type: none"> <li>• Verify that the limit activates at the correct location in the hoistway.</li> <li>• Verify the speed that the car hits the limit and adjust the limit velocity if necessary.</li> <li>• If the acceleration or deceleration rates were changed after the limit velocities were learned, the learn process may need to be repeated or the limit may need to be moved.</li> </ul> <p><b>SEE: SPB ETS Down Spd Flt</b></p>

Fault	Description	Possible Cause/Suggested Fix
ETS Failed On Bottom FI	While at the bottom floor, the car detected that the ETS input did not go off as expected.	<ul style="list-style-type: none"> <li>• The ETS input on the Main I/O board failed on. Replace the input chip.</li> <li>• The ETS magnet is too far from the sensor.</li> <li>• The ETS magnet fell of the rail bracket.</li> <li>• The ETS magnet rail bracket was moved or hit.</li> <li>• The ETS output from the selector failed on. Replace the output chip.</li> <li>• The ETS sensor failed in the on position. Replace the sensor.</li> </ul>
ETS Failed On Top FI	While at the top floor, the car detected that the ETS input did not go off as expected.	<ul style="list-style-type: none"> <li>• The ETS input on the Main I/O board failed on. Replace the input chip.</li> <li>• The ETS magnet is too far from the sensor.</li> <li>• The ETS magnet fell of the rail bracket.</li> <li>• The ETS magnet rail bracket was moved or hit.</li> <li>• The ETS output from the selector failed on. Replace the output chip.</li> <li>• The ETS sensor failed in the on position. Replace the sensor.</li> </ul>
ETS Up Flt Set EBrk	Safety Processor detected a car speed at the ETS Up terminal limit that was greater than the clamp (parameter) speed. The Safety Processor will drop the Emergency Brake if the Reduced Stroke Buffer option is selected.	<ul style="list-style-type: none"> <li>• Verify that the limit activates at the correct location in the hoistway.</li> <li>• Verify the speed that the car hits the limit and adjust the limit velocity if necessary.</li> <li>• If the acceleration or deceleration rates were changed after the limit velocities were learned, the learn process may need to be repeated or the limit may need to be moved.</li> </ul> <p><b>See: SPB ETS Up Flt Set EB</b></p>
ETS Up Speed Fault	Safety Processor detected a car speed at the ETS Up terminal limit that was greater than the clamp (parameter) speed	<ul style="list-style-type: none"> <li>• Verify that the limit activates at the correct location in the hoistway.</li> <li>• Verify the speed that the car hits the limit and adjust the limit velocity if necessary.</li> <li>• If the acceleration or deceleration rates were changed after the limit velocities were learned, the learn process may need to be repeated or the limit may need to be moved.</li> </ul> <p><b>See: SPB ETS Up Speed Flt</b></p>

Fault	Description	Possible Cause/Suggested Fix
FDoor Close Cont Flt	Door Close Contact safe fault	<ul style="list-style-type: none"> <li>• After Controller was safe with doors, gate switch, door contacts and locks made and ready to run, a door contact input turned OFF.</li> </ul>
FEP Fuse Blown Fault	Fire/Emergency Circuit Fuse is Blown	<ul style="list-style-type: none"> <li>• Short Circuit on the FEP Circuit.</li> </ul>
FETST OFF Fault	Front Door Electric Eye Test Failed OFF. Output is turned on cause the electric eye outputs to controller input EE1 and EE2 to pulse.	<ul style="list-style-type: none"> <li>• FETST output or FETST input failed in the off state.</li> <li>• Replace the FETST output chip.</li> <li>• Replace the FETST input chip.</li> </ul>
FETST ON Fault	Front Door Electric Eye Test Failed ON. Output is turned on cause the electric eye outputs to controller input EE1 and EE2 to pulse.	<ul style="list-style-type: none"> <li>• FETST output or FETST input failed in the on state.</li> <li>• Replace the FETST output chip.</li> <li>• Replace the FETST input chip.</li> </ul>
Field Vars Deflt Ini	Field Variables Default Initialization. Field adjustable variables are being initialized for the first time.	<ul style="list-style-type: none"> <li>• Job related parameters are invalid. This error occurs on the first time the GALX-1100 CPU board is being powered up.</li> </ul>
Field Vars Relocated	Field Variables Relocated.	<p>The software has been updated to a newer version that required parameters to be relocated. This is normal and should only occur once. <b>If an older version software is later installed, the job parameters may be lost.</b></p>
Fire Fighter Stop Sw	Fire Fighter Stop Sw	<ul style="list-style-type: none"> <li>• Fire Fighter Stop switch is pulled.</li> <li>• Faulty wire connection in the Fire Fighter stop switch circuit.</li> </ul>

Fault	Description	Possible Cause/Suggested Fix
Fld Var Partial Init	Field variables partial table initialized. Controller did not see extended memory initialized before. It should occur once when updating controller software	<ul style="list-style-type: none"> <li>• The software has been updated. This is normal and should only occur once. If fault constantly occurs please contact GAL.</li> </ul>
Front Det Edge Fault	Front Detector Edge Time-out	<ul style="list-style-type: none"> <li>• The Electric Eye signal stayed on continuously for longer than the parameter 'EE Time-out' is set to.</li> </ul>
FST I/O Failed Off	The FST input on the GALX-1102 board did not pick up when expected.	<ul style="list-style-type: none"> <li>• Faulty FST output chip. Replace output chip.</li> <li>• Faulty FSTI input chip. Replace input chip.</li> </ul>
FST I/O Failed On	The FST input on the GALX-1102 board did not drop out when expected.	<ul style="list-style-type: none"> <li>• Faulty FST output chip. Replace output chip.</li> <li>• Faulty FSTI input chip. Replace input chip.</li> </ul>
FSTP I/O Failed Off	The FSTP input on the GALX-1102 board did not pick up when expected.	<ul style="list-style-type: none"> <li>• Faulty FST1 output chip. Replace output chip.</li> <li>• Faulty FSTI input chip. Replace input chip.</li> </ul>
FSTP I/O Failed On	The FSTP input on the GALX-1102 board did not drop out up when expected	<ul style="list-style-type: none"> <li>• Faulty FST1 output chip. Replace output chip.</li> <li>• Faulty FSTI input chip. Replace input chip.</li> </ul>
FVARS Backup Init	Field Variables Backup Init. Field variables backed up for the first time.	Older software did not backup the field variables. When new software replaces the older software this error will be displayed. If this error occurs every time the CPU powers up, then the CPU may be faulty and should be replaced.

Fault	Description	Possible Cause/Suggested Fix
FVARS Backup Tbl Cksm	Field Variables Backup Table Checksum Error. The verification checksum for the backup field variable table has failed.	During power outages or brown-outs, enough noise can be generated on the 5V DC supply to cause an error in reading the field variables table on power up. For this reason we keep the data in two separate tables. If only one table checksum error occurs, then valid data will be restored. No action is required.
FVARS Backup Tbl Err	Field Variables Backup Table Error. The field variables from the backup MRAM table does not match the variable read into memory from the main MRAM table.	Most likely, if this error occurs, other FVARS errors will also occur. A once-in-a-while occurrence of this error can be ignored if it is not accompanied by the following errors: FVARS Both Tbl Chksum error or FVARS Tbl Chksum Error. If either error occurs with this error, the main CPU board should be replaced.
FVARS Both Tbl Chksum	Field Variables Both Table Checksum Table error. The verification checksum for both the main field variable table and backup table has failed.	Field Variable data is stored in two separate MRAM tables and a checksum of each table is stored in a separate location. When the system powers up, the checksum of each table is verified. If one table fails verification, the field variables are copied from the table that passed verification and then both tables are updated with valid data. If both checksum verifications fail, data is copied from the main table and an error code is displayed. <ul style="list-style-type: none"> <li>• If this fault occurs, replace the main CPU board.</li> </ul>
FVARS Tbl Chksum Err	Field Variables Table Checksum Error. The verification checksum for the main field variable table has failed.	During power outages or brown-outs, enough noise can be generated on the 5V DC supply to cause an error in reading the field variables table on power up. For this reason we keep the data in two separate tables. If only one table checksum error occurs, then valid data will be restored. No action is required.
Gate Switch Fault	The Gate Switch failed on while the door was open.	<ul style="list-style-type: none"> <li>• Gate switch not adjusted properly.</li> <li>• GS input failed on. Replace GS input on the GALX-1102 board.</li> </ul>

Fault	Description	Possible Cause/Suggested Fix
Gate/Lock Byp Sw Flt	The gate or lock bypass switch was on while the car was NOT on car top inspection.	<ul style="list-style-type: none"> <li>• Gate or Lock bypass switch on the controller the GALX-1102 board is in the on position.</li> <li>• Gate or Lock bypass input failed on. Replace GBP OR LBP input chip on 1102 board.</li> </ul>
GOV Overspeed Trip	Governor Overspeed Trip. An ascending overspeed fault occurred from the governor switch opening. This fault sets the gripper or emergency brake.	<ul style="list-style-type: none"> <li>• Verify that the car runs controlled on inspection. If not, increase the response, inertia or gains of the drive.</li> <li>• Verify that the car runs controlled on automatic. The car may be overshooting the roll into top speed. If so, increase the response, inertia or gains of the drive.</li> <li>• Verify that the car runs properly with full load. If not, adjust the drive.</li> </ul>
Governor Switch Flt	Governor Switch Tripped.	<ul style="list-style-type: none"> <li>• Verify that the governor switch is set properly.</li> <li>• Verify that the drive is setup properly and that the car does not overspeed.</li> </ul>
GOVRi Input On Fault	GOVRi input failed on.	<ul style="list-style-type: none"> <li>• The GOVRi input chip failed. Replace the chip.</li> <li>• The governor reset switch is stuck on.</li> <li>• The GOVRi input is jumped on.</li> </ul>
GRCAN Device Fault	Device on the Group CAN Port has a Fault	<ul style="list-style-type: none"> <li>• Look at the details of the fault. The device name and the error code that caused the fault are listed.</li> <li>• Look up the fault code for the device for debugging information.</li> </ul>
GRCAN Device Reset	Device on the Group CAN Port has reset	<ul style="list-style-type: none"> <li>• Look at the details of the fault. The device name and the error code that caused the fault are listed.</li> <li>• The device requested an initialization packet from the main CPU. Typically this occurs during power up or from a power cycle of the individual device.</li> <li>• Ignore the error if the controller power has been cycled. Otherwise, check the device communications and power connections.</li> </ul>

Fault	Description	Possible Cause/Suggested Fix
Gripper did not Pick	The rope gripper did not pick when the GR1 and GR2 relays were energized.	<ul style="list-style-type: none"> <li>• Faulty wiring to the rope gripper.</li> <li>• Faulty GTS switch on rope gripper. Make sure that the switch opens and closes properly when the gripper is energized and dropped.</li> <li>• Faulty GTS input. Replace the GTS input chip.</li> </ul>
Gripper Trip Fault	An overspeed or uncontrolled motion caused the rope gripper to trip.	<ul style="list-style-type: none"> <li>• Check if the governor has tripped.</li> <li>• Make sure that the brake can hold the car.</li> </ul>
Group Comm Loss	The car that was acting as the group car has stopped communicating.	<ul style="list-style-type: none"> <li>• Faulty wiring from TX+/TX- from car to car.</li> <li>• Faulty U6 driver chip on the GALX-1100 CPU board (next to the connector for the group comm). Call GAL.</li> <li>• Noise on shield wire. Connect shield only on one end.</li> <li>• Noise on the communication wires. Run wires in separate conduit.</li> </ul>
Grp Comm Config Err	Group Comm configuration error.	<ul style="list-style-type: none"> <li>• There is a device trying to get initialized that should not be on the bus</li> <li>• Check detailed fault data for 'dev' to identify board address</li> </ul>
GRT1 input Off Fault	While testing the rope gripper relays, the contacts for GR1R or GR2R did not close or the GRT1 input failed off.	<ul style="list-style-type: none"> <li>• Faulty GR1R or GR2R relays. Replace both GR1R and GR2R relays.</li> <li>• Faulty GRT1 input. Replace the GRT1 input chip.</li> </ul>
GRT1 input On Fault	While testing the rope gripper relays, the contacts for GR1R or GR2R did not open or the GRT1 input failed on.	<ul style="list-style-type: none"> <li>• Faulty GR1R or GR2R relays. Replace both GR1R and GR2R relays.</li> <li>• Faulty GRT1 input. Replace the GRT1 input chip.</li> </ul>

Fault	Description	Possible Cause/Suggested Fix
GRT2 input Off Fault	While in a door zone the DZ and DZ1 contacts used in the rope gripper circuit were not closed or the GRT2 input failed off.	Faulty DZ or DZ1 relays. Replace both DZ and DZ1 relays. <ul style="list-style-type: none"> <li>• Faulty GRT2 input. Replace the GRT2 input chip.</li> </ul> Faulty LE1 or LE2 outputs. When a DZ input is on from the selector DZ output, LE1 and LE2 outputs control the DZ and DZ1 relays respectively. Replace the LE1 and LE2 output chips.
GRT2 input On Fault	The DZ and DZ1 contacts used in the rope gripper circuit did not open during a run or the GRT2 input failed on.	Faulty DZ or DZ1 relays. Replace both DZ and DZ1 relays. <ul style="list-style-type: none"> <li>• Faulty GRT2 input. Replace the GRT2 input chip.</li> </ul> Faulty LE1 or LE2 outputs. When a DZ input is on from the selector DZ output, LE1 and LE2 outputs control the DZ and DZ1 relays respectively. Replace the LE1 and LE2 output chips.
GS & GS_1 Opposite	Input failure on one of the Gate Switch (GS) inputs.	<ul style="list-style-type: none"> <li>• GS or GS-1 input failed on. Replace GS or GS-1 input chip.</li> <li>• Check status of input from Input and Output menu on the LCD interface.</li> </ul>
GTS Input Off Fault	Emergency Brake: GTS input did not turn on while doing the safety check for PFC and SFC relays.	<ul style="list-style-type: none"> <li>• Check wiring for emergency brake</li> <li>• Check emergency brake relays during safety check</li> <li>• Faulty GTS input chip. Replace input chip.</li> </ul>
GTS Input On Fault	Emergency Brake: GTS input did not turn off while doing the safety check for PFC and SFC relays.	<ul style="list-style-type: none"> <li>• Check wiring for emergency brake</li> <li>• Check emergency brake relays during safety check</li> <li>• Faulty GTS input chip. Replace input chip.</li> </ul>
Hall Call Light Fuse	Hall Call Light Fuse Blown	<ul style="list-style-type: none"> <li>• Check for short on the Hall Call Light circuit.</li> </ul>
Hatch Safety Fault	Hatch Safety Fault	The HSS input is off. <ul style="list-style-type: none"> <li>• A device contact in the hatch safety string has opened.</li> <li>• The HSS input has failed off.</li> </ul>



Fault	Description	Possible Cause/Suggested Fix
HC Com Device Reset	Serial Hall Call board reset unexpectedly. Usually caused by loss of power to the individual board.	<ul style="list-style-type: none"> <li>• Usually caused by loss of power to the individual board.</li> <li>• Faulty power connection to board.</li> <li>• Fault hall call board.</li> </ul>
HC DrvBd Rx from Bot	Not receiving packets from the bottom station	<ul style="list-style-type: none"> <li>• Cable is bad or disconnected</li> <li>• Cables going to wrong port (i.e., switched TO ABOVE and TO BELOW)</li> <li>• Transmitter from device above or below is bad, check faults for that device.</li> <li>• Receiver on board is bad – replace device</li> </ul>
HC DrvBd Tx to Bot	Can't internally read information from Transmitter to bottom station	<ul style="list-style-type: none"> <li>• Cable connecting two devices could be flip-flopped (i.e., gray wire goes from pin 1 on one end to pin 8 on the other end). Disconnect cable, and if fault changes to Rx Fault, the problem is the cable.</li> <li>• Cables going to wrong port (i.e., switched TO ABOVE and TO BELOW)</li> <li>• Transmitter is bad – replace the Device.</li> </ul>
HC DvrBd Rx from Top	Not receiving packets from the top station.	<ul style="list-style-type: none"> <li>• Cable is bad or disconnected</li> <li>• Cables going to wrong port (i.e., switched TO ABOVE and TO BELOW)</li> <li>• Transmitter from device above or below is bad, check faults for that device.</li> <li>• Receiver on board is bad – replace device</li> </ul>
HC DvrBd Too Few Dev	Too Few stations detected based on configuration – will only trigger if loop is closed (i.e. will not trigger if device #5 is not functioning, causing driver to establish communication with all but one station.)	<ul style="list-style-type: none"> <li>• Check configuration and number of stations</li> </ul>

Fault	Description	Possible Cause/Suggested Fix
HC DvrBd TooMany Dev	Too Many stations detected based on configuration.	<ul style="list-style-type: none"> <li>• Check configuration and number of stations</li> </ul>
HC DvrBd Tx to Top	Can't internally read information from Transmitter to top station.	<ul style="list-style-type: none"> <li>• Cable connecting two devices could be flip-flopped (i.e., gray wire goes from pin 1 on one end to pin 8 on the other end). Disconnect cable, and if fault changes to Rx Fault, the problem is the cable.</li> <li>• Cables going to wrong port (i.e., switched TO ABOVE and TO BELOW)</li> <li>• Transmitter is bad – replace the Device.</li> </ul>
HC Fuse Blown Fault	The HC input is off. No power on HC.	<ul style="list-style-type: none"> <li>• Make sure that the hall call power for each car is in phase. During a power up for car 1 while car 2 is powering the hall call power could cause a momentary short if the hall call power for each car is not in phase.</li> <li>• Short circuit in the hall call lighting circuitry.</li> </ul>
HCB Ax Dn Input Ovld	HCB Aux Down input overload	<ul style="list-style-type: none"> <li>• Controller detected overload in the input from the Aux terminal at the station. To identify fault device refer to Detailed Fault Log 'dev' and 'dv2' will provide address for Serial Driver address and Station where the fault was generated.</li> </ul>
HCB Ax Up Input Ovld	HCB Aux Up input overload	<ul style="list-style-type: none"> <li>• Controller detected overload in the input from the Aux terminal at the station. To identify fault device refer to Detailed Fault Log 'dev' and 'dv2' will provide address for Serial Driver address and Station where the fault was generated.</li> </ul>
HCB Device Comm Loss	The Driver does not see this HCB device	<ul style="list-style-type: none"> <li>• Comm faults above and below a device – check wiring</li> <li>• Board not powering up – check 24VAC and MCU on device</li> <li>• Fuses blown on driver</li> </ul>

Fault	Description	Possible Cause/Suggested Fix
HCB Device Reset	The HCB has just comeback online	<ul style="list-style-type: none"> <li>• Fixed previous problem.</li> </ul> There is a power/communication problem, where the board is either resetting (power) or temporarily losing communication on both ports.
HCB Dn FET Open	HCB fet open down	<ul style="list-style-type: none"> <li>• Replace GALX-1054AN</li> </ul>
HCB Dn FET Short	HCB fet short down	<ul style="list-style-type: none"> <li>• Replace GALX-1054AN</li> </ul>
HCB Dn Input Ovrload	HCB Down input overload	<ul style="list-style-type: none"> <li>• Controller detected overload in the input from the LED board at the station. To identify fault device refer to Detailed Fault Log 'dev' and 'dv2' will provide address for Serial Driver address and Station where the fault was generated.</li> </ul>
HCB Dn LED Open	HCB led open down	<ul style="list-style-type: none"> <li>• Make Sure there is a GALX-1056AN attached to the proper connector (Up LED always attached to CN5, Down LED attached to CN5 if only down call at that station (like the top floor), otherwise attached via ribbon at CN6.</li> <li>• Replace GALX-1056AN for the associated up or down call.</li> </ul>
HCB Dn LED Short	HCB led short down	<ul style="list-style-type: none"> <li>• Make Sure there is a GALX-1056AN attached to the proper connector (Up LED always attached to CN5, Down LED attached to CN5 if only down call at that station (like the top floor), otherwise attached via ribbon at CN6.</li> <li>• Replace GALX-1056AN for the associated up or down call.</li> </ul>
HCB FET Open Blue Dn	HCB fet open blue down	<ul style="list-style-type: none"> <li>• Replace the GALX-1093AN board – dev / dev 2 can pinpoint which 1093 is at fault.</li> </ul>
HCB FET Open Blue Up	HCB fet open blue up	<ul style="list-style-type: none"> <li>• Replace the GALX-1093AN board – dev / dev 2 can pinpoint which 1093 is at fault.</li> </ul>

Fault	Description	Possible Cause/Suggested Fix
HCB FET Open Grn Dn	HCB fet open green down	<ul style="list-style-type: none"> <li>• Replace the GALX-1093AN board – dev / dev 2 can pinpoint which 1093 is at fault.</li> </ul>
HCB FET Open Grn Up	HCB fet open green up	<ul style="list-style-type: none"> <li>• Replace the GALX-1093AN board – dev / dev 2 can pinpoint which 1093 is at fault.</li> </ul>
HCB FET Open Red Dn	HCB fet open red down	<ul style="list-style-type: none"> <li>• Replace the GALX-1093AN board – dev / dev 2 can pinpoint which 1093 is at fault.</li> </ul>
HCB FET Open Red Up	HCB fet short red up	<ul style="list-style-type: none"> <li>• Replace the GALX-1093AN board – dev / dev 2 can pinpoint which 1093 is at fault.</li> </ul>
HCB FET Short Blu Dn	HCB fet short blue down	<ul style="list-style-type: none"> <li>• Replace the GALX-1093AN board – dev / dev 2 can pinpoint which 1093 is at fault.</li> </ul>
HCB FET Short Blu Up	HCB fet short blue up	<ul style="list-style-type: none"> <li>• Replace the GALX-1093AN board – dev / dev 2 can pinpoint which 1093 is at fault.</li> </ul>
HCB FET Short Grn Dn	HCB fet short green down	<ul style="list-style-type: none"> <li>• Replace the GALX-1093AN board – dev / dev 2 can pinpoint which 1093 is at fault.</li> </ul>
HCB FET Short Grn Up	HCB fet short green up	<ul style="list-style-type: none"> <li>• Replace the GALX-1093AN board – dev / dev 2 can pinpoint which 1093 is at fault.</li> </ul>
HCB FET Short Red Dn	HCB fet short red down	<ul style="list-style-type: none"> <li>• Replace the GALX-1093AN board – dev / dev 2 can pinpoint which 1093 is at fault.</li> </ul>
HCB FET Short Red Up	HCB fet short red up	<ul style="list-style-type: none"> <li>• Replace the GALX-1093AN board – dev / dev 2 can pinpoint which 1093 is at fault.</li> </ul>
HCB Invalid Floor	HCB has invalid floor	<ul style="list-style-type: none"> <li>• This fault is only intended for internal use to identify floors that need to be skipped in diagnostics. It should never occur</li> </ul>

Fault	Description	Possible Cause/Suggested Fix
HCB LED Open Blue Dn	HCB led open blue down	<ul style="list-style-type: none"> <li>• Make Sure there is a GALX-1056AN attached to the proper connector (Up LED always attached to CN5, Down LED attached to CN5 if only down call at that station (like the top floor), otherwise attached via ribbon at CN6.</li> <li>• Replace GALX-1056AN for the associated up or down call.</li> </ul>
HCB LED Open Blue Up	HCB led open blue up	<ul style="list-style-type: none"> <li>• Make Sure there is a GALX-1056AN attached to the proper connector (Up LED always attached to CN5, Down LED attached to CN5 if only down call at that station (like the top floor), otherwise attached via ribbon at CN6.</li> <li>• Replace GALX-1056AN for the associated up or down call.</li> </ul>
HCB LED Open Grn Dn	HCB led open green down	<ul style="list-style-type: none"> <li>• Make Sure there is a GALX-1056AN attached to the proper connector (Up LED always attached to CN5, Down LED attached to CN5 if only down call at that station (like the top floor), otherwise attached via ribbon at CN6.</li> <li>• Replace GALX-1056AN for the associated up or down call.</li> </ul>
HCB LED Open Grn Up	HCB led open green up	<ul style="list-style-type: none"> <li>• Make Sure there is a GALX-1056AN attached to the proper connector (Up LED always attached to CN5, Down LED attached to CN5 if only down call at that station (like the top floor), otherwise attached via ribbon at CN6.</li> <li>• Replace GALX-1056AN for the associated up or down call.</li> </ul>
HCB LED Open Red Dn	HCB led open red down	<ul style="list-style-type: none"> <li>• Make Sure there is a GALX-1056AN attached to the proper connector (Up LED always attached to CN5, Down LED attached to CN5 if only down call at that station (like the top floor), otherwise attached via ribbon at CN6.</li> <li>• Replace GALX-1056AN for the associated up or down call.</li> </ul>

Fault	Description	Possible Cause/Suggested Fix
HCB LED Open Red Up	HCB led short red up	<ul style="list-style-type: none"> <li>• Make Sure there is a GALX-1056AN attached to the proper connector (Up LED always attached to CN5, Down LED attached to CN5 if only down call at that station (like the top floor), otherwise attached via ribbon at CN6.</li> <li>• Replace GALX-1056AN for the associated up or down call.</li> </ul>
HCB LED Short Blu Dn	HCB led short blue down	<ul style="list-style-type: none"> <li>• Make Sure there is a GALX-1056AN attached to the proper connector (Up LED always attached to CN5, Down LED attached to CN5 if only down call at that station (like the top floor), otherwise attached via ribbon at CN6.</li> <li>• Replace GALX-1056AN for the associated up or down call.</li> </ul>
HCB LED Short Blu Up	HCB led short blue up	<ul style="list-style-type: none"> <li>• Make Sure there is a GALX-1056AN attached to the proper connector (Up LED always attached to CN5, Down LED attached to CN5 if only down call at that station (like the top floor), otherwise attached via ribbon at CN6.</li> <li>• Replace GALX-1056AN for the associated up or down call.</li> </ul>
HCB LED Short Grn Dn	HCB led short green down	<ul style="list-style-type: none"> <li>• Make Sure there is a GALX-1056AN attached to the proper connector (Up LED always attached to CN5, Down LED attached to CN5 if only down call at that station (like the top floor), otherwise attached via ribbon at CN6.</li> <li>• Replace GALX-1056AN for the associated up or down call.</li> </ul>
HCB LED Short Grn Up	HCB led short green up	<ul style="list-style-type: none"> <li>• Make Sure there is a GALX-1056AN attached to the proper connector (Up LED always attached to CN5, Down LED attached to CN5 if only down call at that station (like the top floor), otherwise attached via ribbon at CN6.</li> <li>• Replace GALX-1056AN for the associated up or down call.</li> </ul>

Fault	Description	Possible Cause/Suggested Fix
HCB LED Short Red Dn	HCB led short red down	<ul style="list-style-type: none"> <li>• Make Sure there is a GALX-1056AN attached to the proper connector (Up LED always attached to CN5, Down LED attached to CN5 if only down call at that station (like the top floor), otherwise attached via ribbon at CN6.</li> <li>• Replace GALX-1056AN for the associated up or down call.</li> </ul>
HCB LED Short Red Up	HCB led short red up	<ul style="list-style-type: none"> <li>• Make Sure there is a GALX-1056AN attached to the proper connector (Up LED always attached to CN5, Down LED attached to CN5 if only down call at that station (like the top floor), otherwise attached via ribbon at CN6.</li> <li>• Replace GALX-1056AN for the associated up or down call.</li> </ul>
HCB Low Supply Volt	Hall call board has low supply voltage	<ul style="list-style-type: none"> <li>• Low voltage at Hall call device level. To identify fault device refer to Detailed Fault Log 'dev' and 'dv2' will provide address for Serial Driver address and Station where the fault was generated.</li> </ul>
HCB No Dn LED Board	HCB No Down Led Board Detected	<ul style="list-style-type: none"> <li>• HCB board could not detect an LED board</li> <li>• Replace LED board (GALX-1085AN)</li> </ul>
HCB No Up LED Board	HCB No Up Led Board Detected	<ul style="list-style-type: none"> <li>• HCB board could not detect an LED board</li> <li>• Replace LED board (GALX-1085AN)</li> </ul>
HCB Rx from above fl	HCB Rx fault from above floor	<ul style="list-style-type: none"> <li>• Receiver on board is bad – replace device</li> <li>• Cable is bad or disconnected</li> <li>• Cables going to wrong port (i.e., switched to above and to below)</li> <li>• Transmitter from device above is bad.</li> </ul>
HCB Rx from below fl	HCB Rx fault from below floor	<ul style="list-style-type: none"> <li>• Receiver on board is bad – replace device</li> <li>• Cable is bad or disconnected</li> <li>• Cables going to wrong port (i.e., switched to above and to below)</li> <li>• Transmitter from device below is bad.</li> </ul>

Fault	Description	Possible Cause/Suggested Fix
HCB Stuck Dn Button	HCB stuck button down	<ul style="list-style-type: none"> <li>• Button is physically stuck – fix button</li> <li>• Input is stuck on or shorted – replace device</li> </ul>
HCB Stuck Up Button	HCB stuck button up	<ul style="list-style-type: none"> <li>• Button is physically stuck – fix button</li> <li>• Input is stuck on or shorted – replace device</li> </ul>
HCB Tx to above fl	Can't internally read information from Transmitter to device above	<ul style="list-style-type: none"> <li>• Cable connecting two devices could be flip-flopped (i.e., gray wire goes from pin 1 on one end to pin 8 on the other end). Disconnect cable, and if fault changes to Rx Fault, the problem is the cable.</li> <li>• Transmitter is bad, Replace the Device</li> </ul>
HCB Tx to below fl	Can't internally read information from Transmitter to device below	<ul style="list-style-type: none"> <li>• Cable connecting two devices could be flip-flopped (i.e., gray wire goes from pin 1 on one end to pin 8 on the other end). Disconnect cable, and if fault changes to Rx Fault, the problem is the cable.</li> <li>• Transmitter is bad, Replace the Device</li> </ul>
HCB Up FET Open	HCB fet open up	<ul style="list-style-type: none"> <li>• Replace GALX-1054AN</li> </ul>
HCB Up FET Short	HCB fet short up	<ul style="list-style-type: none"> <li>• Replace GALX-1054AN</li> </ul>
HCB Up Input Ovrload	HCB Up input overload	<ul style="list-style-type: none"> <li>• Controller detected overload in the input from the LED board at the station. To identify fault device refer to Detailed Fault Log 'dev' and 'dv2' will provide address for Serial Driver address and Station where the fault was generated.</li> </ul>
HCB Up LED Open	HCB Up LED open	<ul style="list-style-type: none"> <li>• Make Sure there is a GALX-1056AN attached to the proper connector (Up LED always attached to CN5, Down LED attached to CN5 if only down call at that station (like the top floor), otherwise attached via ribbon at CN6.</li> <li>• Replace GALX-1056AN for the associated up or down call.</li> </ul>



Fault	Description	Possible Cause/Suggested Fix
HCB Up LED Short	HCB Up LED shorted	<ul style="list-style-type: none"> <li>• Make Sure there is a GALX-1056AN attached to the proper connector (Up LED always attached to CN5, Down LED attached to CN5 if only down call at that station (like the top floor), otherwise attached via ribbon at CN6.</li> <li>• Replace GALX-1056AN for the associated up or down call.</li> </ul>
Hoist Motor Overload	Hoist Motor Overload	<ul style="list-style-type: none"> <li>• Hoist Motor Overload signal tripped. Check Input chip for HMO input</li> </ul>
Hoistway Default Ini	Hoistway Default Initialization. Hoistway values are being initialized for the first time.	<ul style="list-style-type: none"> <li>• Job related hoistway setup information is invalid. This occurs on the first time the GALX-1100 CPU board is being powered up.</li> </ul>
Hoistway Learn Fault	Car is on automatic and the hoistway has not been learned.	<ul style="list-style-type: none"> <li>• Hoistway learn procedure needs to be performed.</li> <li>• Faulty ram-flash memory chip.</li> </ul>
Hoistway Update Init	Hoistway Update Initialization. Table of door zone positions for hoistway used to update position count while traveling has been initialized for the first time.	<ul style="list-style-type: none"> <li>• Job related hoistway setup information is invalid. This occurs on the first time the GALX-1100 CPU board is being powered up.</li> </ul>
Hot Oil Fault	Hot Oil Fault	<ul style="list-style-type: none"> <li>• Hydro only - Job is configured for hot oil detect. TPH input turned ON. Check for defective input.</li> </ul>
INS DO Speed Fault	Safety Processor Inspection Door Open Fault	<ul style="list-style-type: none"> <li>• A door is open while running on inspection and the gate and locks are not being bypassed. The car will immediately shut down.</li> </ul> <p><b>See: SPB INS DO Speed Ft</b></p>

Fault	Description	Possible Cause/Suggested Fix
INS Speed Fault	Safety Processor Inspection Speed Fault	<ul style="list-style-type: none"> <li>• The car exceeded the INS Velocity adjustable variable while running on inspection. The car will immediately shut down.</li> </ul> <p><b>See: SPB INS Speed Fault</b></p>
Inspection Input Flt	More than one input is on in the inspection string. The inspection string condition is also shown on the safety processor status screen.	<ul style="list-style-type: none"> <li>• Faulty Top of Car inspection wiring. Verify voltage on CTA and ICA terminals when car top inspection switch is in the run position. Verify INS input when switch in the inspection position.</li> <li>• Verify that one and only one inspection string inputs is on: AUTO, MRI, INS, ICI and ACC.</li> <li>• Faulty inspection string input: AUTO, MRI, INS, ICI or ACC. Replace faulty input chip</li> </ul>
Inspection Up/Dn Sw	An up or down inspection run input was on when first entering into inspection operation. This caused from a faulty inspection up or down switch or from someone holding the up or down run button when placing the car on inspection.	<ul style="list-style-type: none"> <li>• Faulty inspection up or down input: IU, ID, MRIU, MRIU, BAD, BAU, TAD or TAU. Replace faulty input chip.</li> <li>• Faulty inspection wiring keeping an inspection up or down input on.</li> <li>• Placing the car on inspection while holding an up or down run button</li> </ul>
Invalid DT or DT1 Cnt	Invalid DT or DT1 Count. The position count for DT is greater than the count for DT1	<ul style="list-style-type: none"> <li>• Invalid hoistway learn. Re-learn the hoistway.</li> <li>• The hoistway has not been learned. Learn the hoistway.</li> <li>• If this problem is not corrected with a hoistway learn, contact the factory</li> </ul>
Invalid FL Offset Cnt	Invalid Floor Offset Count. If the offset count is greater than 3 inches.	<ul style="list-style-type: none"> <li>• The offset starts out at zero and is modified by the adjuster. This value should never be greater than 3 inches.</li> <li>• Encoder was changed from lower resolution to higher resolution which would cause the offset value to be out of range. Correct the offset value.</li> </ul>

Fault	Description	Possible Cause/Suggested Fix
Invalid DN or DT Cnt	Invalid DN or DT Count. The position count for DN is greater than the count for DT	<ul style="list-style-type: none"> <li>• Invalid hoistway learn. Re-learn the hoistway.</li> <li>• The hoistway has not been learned. Learn the hoistway.</li> <li>• If this problem is not corrected with a hoistway learn, contact the factory</li> </ul>
Invalid Fault	Fault Code Greater than Table Value	<ul style="list-style-type: none"> <li>• Can occur if device program version is newer than the controller program version and the device has a new fault that is not yet recorded in the controller program. Update controller software.</li> </ul>
Invalid Fault Code	Invalid Fault Code	Device error not recognized by controller.
Invalid Floor Count	Invalid Floor Count. The floor count of the floor above must always be larger than the floor below. An above floor count was lower than the floor below in the floor hoistway table	<ul style="list-style-type: none"> <li>• Invalid hoistway learn. Re-learn the hoistway.</li> <li>• The hoistway has not been learned. Learn the hoistway.</li> <li>• If this problem is not corrected with a hoistway learn, contact the factory</li> </ul>
Invalid SEL Bot Cnt	Invalid Selector Bottom Count. (Tapeless selector) The bottom floor count is less than 4000. The count is initialized at 5000.	<ul style="list-style-type: none"> <li>• Invalid hoistway learn. Re-learn the hoistway.</li> <li>• The hoistway has not been learned. Learn the hoistway.</li> <li>• If this problem is not corrected with a hoistway learn, contact the factory</li> </ul>
Invalid SEL Top Cnt	Invalid Selector Top Count. The top selector count minus the bottom selector count is less than the number of floors times 30. The count averaged less than 30 counts per floor.	<ul style="list-style-type: none"> <li>• Invalid hoistway learn. Re-learn the hoistway.</li> <li>• The hoistway has not been learned. Learn the hoistway.</li> <li>• If this problem is not corrected with a hoistway learn, contact the factory</li> </ul>

Fault	Description	Possible Cause/Suggested Fix
Invalid UT or UN Cnt	Invalid UT or UN Count. The position count for UT is greater than the count for UN	<ul style="list-style-type: none"> <li>• Invalid hoistway learn. Re-learn the hoistway.</li> <li>• The hoistway has not been learned. Learn the hoistway.</li> <li>• If this problem is not corrected with a hoistway learn, contact the factory</li> </ul>
Invld DT1 or DT2 Cnt	Invalid DT1 or DT2 Count. The position count for DT1 is greater than the count for DT2	<ul style="list-style-type: none"> <li>• Invalid hoistway learn. Re-learn the hoistway.</li> <li>• The hoistway has not been learned. Learn the hoistway.</li> <li>• If this problem is not corrected with a hoistway learn, contact the factory</li> </ul>
Invld DT2 or DT3 Cnt	Invalid DT2 or DT3 Count. The position count for DT2 is greater than the count for DT3	<ul style="list-style-type: none"> <li>• Invalid hoistway learn. Re-learn the hoistway.</li> <li>• The hoistway has not been learned. Learn the hoistway.</li> <li>• If this problem is not corrected with a hoistway learn, contact the factory</li> </ul>
Invld DT3 or DT4 Cnt	Invalid DT3 or DT4 Count. The position count for DT3 is greater than the count for DT4	<ul style="list-style-type: none"> <li>• Invalid hoistway learn. Re-learn the hoistway.</li> <li>• The hoistway has not been learned. Learn the hoistway.</li> <li>• If this problem is not corrected with a hoistway learn, contact the factory</li> </ul>
Invld DT4 or DT5 Cnt	Invalid DT4 or DT5 Count. The position count for DT4 is greater than the count for DT5	<ul style="list-style-type: none"> <li>• Invalid hoistway learn. Re-learn the hoistway.</li> <li>• The hoistway has not been learned. Learn the hoistway.</li> <li>• If this problem is not corrected with a hoistway learn, contact the factory</li> </ul>
Invld DT5 or DT6 Cnt	Invalid DT5 or DT6 Count. The position count for DT5 is greater than the count for DT6	<ul style="list-style-type: none"> <li>• Invalid hoistway learn. Re-learn the hoistway.</li> <li>• The hoistway has not been learned. Learn the hoistway.</li> <li>• If this problem is not corrected with a hoistway learn, contact the factory</li> </ul>

Fault	Description	Possible Cause/Suggested Fix
InvlD DZU or DZD Cnt	Invalid DZU or DZD Count. If the DZU count is greater than the floor position count or the DZD count is less than the floor position count, then this error is declared.	<ul style="list-style-type: none"> <li>• Invalid hoistway learn. Re-learn the hoistway.</li> <li>• The hoistway has not been learned. Learn the hoistway.</li> <li>• If this problem is not corrected with a hoistway learn, contact the factory</li> </ul>
InvlD UT1 or UT Cnt	Invalid UT1 or UT Count. The position count for UT1 is greater than the count for UT	<ul style="list-style-type: none"> <li>• Invalid hoistway learn. Re-learn the hoistway.</li> <li>• The hoistway has not been learned. Learn the hoistway.</li> <li>• If this problem is not corrected with a hoistway learn, contact the factory</li> </ul>
InvlD UT2 or UT1 Cnt	Invalid UT2 or UT1 Count. The position count for UT2 is greater than the count for UT1	<ul style="list-style-type: none"> <li>• Invalid hoistway learn. Re-learn the hoistway.</li> <li>• The hoistway has not been learned. Learn the hoistway.</li> <li>• If this problem is not corrected with a hoistway learn, contact the factory</li> </ul>
InvlD UT3 or UT2 Cnt	Invalid UT3 or UT2 Count. The position count for UT3 is greater than the count for UT2	<ul style="list-style-type: none"> <li>• Invalid hoistway learn. Re-learn the hoistway.</li> <li>• The hoistway has not been learned. Learn the hoistway.</li> <li>• If this problem is not corrected with a hoistway learn, contact the factory</li> </ul>
InvlD UT4 or UT3 Cnt	Invalid UT4 or UT3 Count. The position count for UT4 is greater than the count for UT3	<ul style="list-style-type: none"> <li>• Invalid hoistway learn. Re-learn the hoistway.</li> <li>• The hoistway has not been learned. Learn the hoistway.</li> <li>• If this problem is not corrected with a hoistway learn, contact the factory</li> </ul>
InvlD UT5 or UT4 Cnt	Invalid UT5 or UT4 Count. The position count for UT5 is greater than the count for UT4	<ul style="list-style-type: none"> <li>• Invalid hoistway learn. Re-learn the hoistway.</li> <li>• The hoistway has not been learned. Learn the hoistway.</li> <li>• If this problem is not corrected with a hoistway learn, contact the factory</li> </ul>

Fault	Description	Possible Cause/Suggested Fix
Invlid UT6 or UT5 Cnt	Invalid UT6 or UT5 Count. The position count for UT6 is greater than the count for UT5	<ul style="list-style-type: none"> <li>• Invalid hoistway learn. Re-learn the hoistway.</li> <li>• The hoistway has not been learned. Learn the hoistway.</li> <li>• If this problem is not corrected with a hoistway learn, contact the factory</li> </ul>
Invlid Top Floor Cnt	Invalid Top Floor Count. The top floor count is zero.	<ul style="list-style-type: none"> <li>• Invalid hoistway learn. Re-learn the hoistway.</li> <li>• The hoistway has not been learned. Learn the hoistway.</li> <li>• If this problem is not corrected with a hoistway learn, contact the factory</li> </ul>
IO Fault	Safety Processor I/O Fault. An input is on in error. The Elevator Status display will show the I/O error.	<ul style="list-style-type: none"> <li>• All inspection inputs and the auto input are off.</li> <li>• More than one inspection or auto input is on at the same time.</li> <li>• A bypass input is on while the car is not on Car top inspection.</li> <li>• Both up and down run output from the main CPU are on at the same time.</li> <li>• The car will not be able to run until the error is cleared.</li> </ul> <p><b>See: SPB IO Fault</b></p>
KEB Not In Run Mode	KEB drive not in run mode. We need to verify that the drive is in Run Mode before we do every Run.	<ul style="list-style-type: none"> <li>• LF.03 was not set to zero with the car in automatic. If the error occurred while troubleshooting disregard error. If it happens when in service, check drive for possible cause of this parameter not being set properly.</li> </ul>
L1 Low Line Voltage	L1 Line Voltage Low	<ul style="list-style-type: none"> <li>• Voltage Sensor Board Related. Voltage being monitored on L1 dropped below the setting for parameter ' Low Line Volt '</li> </ul>
L2 Low Line Voltage	L2 Line Voltage Low	<ul style="list-style-type: none"> <li>• Voltage Sensor Board Related. Voltage being monitored on L2 dropped below the setting for parameter ' Low Line Volt '</li> </ul>
L3 Low Line Voltage	L3 Line Voltage Low	<ul style="list-style-type: none"> <li>• Voltage Sensor Board Related. Voltage being monitored on L3 dropped below the setting for parameter ' Low Line Volt '</li> </ul>

Fault	Description	Possible Cause/Suggested Fix
Learn HW Safe Fault	Part of the safety string open while in automatic learn hoistway mode	<ul style="list-style-type: none"> <li>• Check for possible faults on the safety processor or drive</li> <li>• Door locks, gate switch or contacts open while in motion</li> </ul>
Learn HW Stall Fault	Car timed out while learning hoistway in auto	<ul style="list-style-type: none"> <li>• Increase field variable 'Hoistway Learn Stall Time' and try again</li> </ul>
Lev Flt Set EM Brake	Emergency brake set from leveling fault	<ul style="list-style-type: none"> <li>• A leveling fault occurred and the parameter 'Adjustable Options-&gt;Car Options-&gt;Leveling Fault = ' is set so it trips the Rope Gripper/Emergency Brake</li> </ul>
Lev Flt Set Gripper	Gripper set from leveling fault	<p>A leveling fault occurred and the field variable 'Adjustable Options-&gt;Car Options-&gt;Leveling Fault = ' is set to 1=Set Grip/EB so it trips the Rope Gripper/Emergency Brake. Verify that the car relevels properly.</p> <ul style="list-style-type: none"> <li>• Adjust car leveling speed.</li> <li>• Adjust drive response.</li> <li>• Adjust relevel brake parameters.</li> <li>• See Leveling Fault.</li> </ul>
LEV Speed Fault	Safety Processor I/O Fault. An input is on in error. The Elevator Status display will show the I/O error.	<ul style="list-style-type: none"> <li>• Car was traveling at a speed greater than the leveling speed parameter in the door zone with the door open.</li> <li>• Leveling Vel adjustable variable may be set too low.</li> </ul> <p><b>See: SPB Lev Speed Fault</b></p>
Level Stop Cnt Fault	Leveling stop fault occurred from incorrect count. As the car was leveling off the pulses, UL or DL turned off.	<ul style="list-style-type: none"> <li>• Floor offset value set too high. Increase dead zone when the car is configured to stop on the pulses instead of just the magnet</li> <li>• Ensure outer sensors are set no more than 7.5 inches apart</li> </ul>

Fault	Description	Possible Cause/Suggested Fix
Leveling Fault	<p>Leveling Fault. When the controller attempted to drop the brake, the car moved out of the dead level. The leveling fault count was incremented. If this occurs more times than the adjustable variable 'Level Fault Cnt' then this error is declared.</p>	<ul style="list-style-type: none"> <li>• Brake is dropping too slowly. Adjust the drop of the brake. The drive is not holding zero speed. Run the car on inspection at 5fpm and while running change the inspection speed to zero. The car should stop and hold zero.</li> <li>• The response is not high enough on the drive.</li> <li>• Brake contactor is not dropping properly.</li> </ul>
Leveling Tim-out Flt	<p>Leveling Time-out Fault</p>	<ul style="list-style-type: none"> <li>• Car overshot the floor and continued leveling.</li> <li>• Car targeted floor too soon and was creeping to the floor in leveling.</li> <li>• Check for causes of invalid pulse counts or invalid floor positions</li> <li>• Invalid floor position preset</li> <li>• Faulty encoder connection</li> <li>• Faulty encoder wiring</li> </ul>
Limit Opp Dir Flt	<p>Car hit limits in wrong direction. In a single Run every Limit switch signal should only change state once or not change at all. If car was travelling down and an Up Terminal Slowdown switch goes LOW after we go in motion we will detect that as a fault. This fault will drop the gripper or emergency brake. Disable this fault with field variable Lim Dir Flt Dis set to 1=Disabled.</p>	<ul style="list-style-type: none"> <li>• If Controller is not really faulting, check that Slowdowns are not at the same position as the dead level position. On Gearless jobs roll back could cause this extra change of state and therefore generate the fault. In that event reposition Terminal Slowdown by a couple of inches.</li> </ul>



Fault	Description	Possible Cause/Suggested Fix
Load Weigh Var Init	Load weigher init	<ul style="list-style-type: none"> <li>• Invalid load weigher table on power up. The load weigher table will be re-initialized to zero <b>and the load weigher must be setup again.</b></li> <li>• If this error persist, the MRAM on the CPU board is faulty. Replace the CPU board.</li> <li>• Ignore this error if the load weigher is not being used.</li> </ul>
Lobby Hall Call Fuse	Lobby Call common fuse	<ul style="list-style-type: none"> <li>• Lobby Common fuse blown. Check Input chip for LHC</li> </ul>
Low Pressure Fault	Low Oil Pressure Fault. The low oil pressure switch has been activated.	<ul style="list-style-type: none"> <li>• Low oil in the tank.</li> <li>• Faulty LOS input if low oil switch option is being used. Replace the LOS input chip.</li> <li>• Faulty Low Oil Switch. If low oil switch option is being used.</li> <li>• Verify the operation of the low oil switch.</li> </ul>
Lowoil Switch Fault	Low Oil Switch Fault. The low oil switch became active	<p><b>Hydro.</b></p> <ul style="list-style-type: none"> <li>• Low oil in the hydraulic tank</li> <li>• Faulty wiring to the low oil input</li> <li>• Faulty low oil input. Replace LOS input.</li> </ul>
LW Calibration Error	Load Weigher Calibration Error. The load weigher attempted to do an automatic calibration and could not be calibrated.	The load weigher device should be re-calibrated according to the manufacturer’s instructions.
LW Load Table Fault	A fault was detected in the Load weigher load tables. The empty load value was greater than or equal to the full load value at a valid floor.	<ul style="list-style-type: none"> <li>• The load weigher might not be calibrated properly</li> <li>• The load weigher setup might have been interrupted before being completed.</li> <li>• Faulty load weigher device.</li> <li>• The load weigher device is not setup.</li> <li>• The load weigher data was not stored properly in the MRAM memory or was not read in properly on power up.</li> <li>• Invalid load weigher data read from or written to the SD card during an SD card job setup read.</li> </ul>

Fault	Description	Possible Cause/Suggested Fix
Machine Room Stop Sw	Machine Room Stop Switch is Opened	<ul style="list-style-type: none"> <li>• Turn off the Machine Room Stop Switch.</li> <li>• Faulty Machine Room Stop Switch</li> </ul>
MCA I/O Failed Off	The MCA input or output has failed off.	<ul style="list-style-type: none"> <li>• Faulty MCAi input chip. Replace input chip.</li> <li>• Faulty MCA output chip. Replace output chip.</li> </ul>
MCA I/O Failed On	The MCA input or output has failed on.	<ul style="list-style-type: none"> <li>• Faulty MCAi input chip. Replace input chip.</li> <li>• Faulty MCA output chip. Replace output chip.</li> </ul>
MCC I/O Failed Off	The MCC input or output has failed off.	<ul style="list-style-type: none"> <li>• Faulty MCCi input chip. Replace input chip.</li> <li>• Faulty MCC output chip. Replace output chip.</li> </ul>
MCC I/O Failed On	The MCC input or output has failed on.	<ul style="list-style-type: none"> <li>• Faulty MCCi input chip. Replace input chip.</li> <li>• Faulty MCC output chip. Replace output chip.</li> </ul>
MCX Off Fault	The MCX contact is off when it is expected to be on.	<ul style="list-style-type: none"> <li>• Faulty Auxiliary MC Contact. Replace the AUX contact block or wire to a spare contact (if available).</li> <li>• Faulty MCX input chip. Replace the input chip.</li> </ul>
MCX On Fault	The MCX contact is on when it is expected to be off.	<ul style="list-style-type: none"> <li>• Faulty Auxiliary MC Contact. Replace the AUX contact block or wire to a spare contact (if available).</li> <li>• Faulty MCX input chip. Replace the input chip.</li> </ul>
Mid Door Lock Fault	The Middle Door Lock failed on while the door was open.	<p>Faulty door lock.</p> <ul style="list-style-type: none"> <li>• Jumper on door lock circuit.</li> <li>• Door lock not adjusted properly.</li> <li>• Faulty wiring to DLM input.</li> </ul> <p>Faulty DLM and DLM-1 inputs (For this to occur both DLM and DLM-1 inputs must fail on).</p> <ul style="list-style-type: none"> <li>• DOL input failed. Replace DOL input chip.</li> <li>• Door operator open limit DOL is not adjusted properly</li> </ul>
Motion Exit GTS Flt	GTS Motion emergency exit	<p>GTS input opened unexpectedly during a run.</p> <ul style="list-style-type: none"> <li>• Fault GTS switch on the rope gripper. Replace or correct the switch activation</li> </ul>

Fault	Description	Possible Cause/Suggested Fix
Motion Exit Ins Flt	Emergency motion exit from inspection	Car was in motion before going in inspection Mode. Check for inspection inputs faulting out or Automatic input going low.
MRAM Hardware Fault	MRAM Fault	The MRAM is tested on power up and has failed the test. Replace the CPU board.
MRAM Write Error	MRAM Write Error. After parameter data RAM has been modified through the user interface, the data is automatically written to MRAM for non-volatile storage. After the data is stored it is compared with the original parameter data. If it does not match a fault is recorded.	<ul style="list-style-type: none"> <li>• This error should not occur. If it does occur, the problem is either a fault CPU board or MRAM chip. Replace the CPU board.</li> </ul>
MRCAN Device Fault	Device on the Machine Room CAN Port has a Fault	<ul style="list-style-type: none"> <li>• Look at the details of the fault. The device name and the error code that caused the fault are listed.</li> <li>• Look up the fault code for the device for debugging information.</li> </ul>
MRCAN Device Reset	Device on the Machine Room CAN Port has reset	<ul style="list-style-type: none"> <li>• Look at the details of the fault. The device name and the error code that caused the fault are listed.</li> <li>• The device requested an initialization packet from the main CPU. Typically this occurs during power up or from a power cycle of the individual device.</li> <li>• Ignore the error if the controller power has been cycled. Otherwise, check the device communications and power connections.</li> </ul>

Fault	Description	Possible Cause/Suggested Fix
No Pulses Fault	Safety Processor Pulse Error.	<ul style="list-style-type: none"> <li>• Not enough pulses have occurred during the Pulse Fault Time period. This error is detected only on automatic operation.</li> <li>• Verify that the encoder LED for the Safety Processor on the Main I/O board blinks while the car is running on inspection.</li> <li>• Also verify that the Safety Processor Velocity displayed on the 'Elevator Status' display is correct.</li> </ul> <p>Possible causes are as follows:</p> <ul style="list-style-type: none"> <li>• Improper connection to the motor encoder. Refer to the job specific prints.</li> <li>• Improper connection of encoder jumpers on Main I/O board.</li> </ul> <p><b>See: SPB No Pulses Fault</b></p>
Norm Lim Clk Pulse Flt	Selector pulsed the clock of the UN or DN latch multiple times but the state was not latched	<p>Hardware fault. Replace the Selector Driver board.</p> <p><b>See: SEL Norm Clk Flt</b></p>
NTS CAN Error MRCAN	NTS Processor is not communicating on the Machine Room CAN Bus.	<ul style="list-style-type: none"> <li>• Improper CAN Bus termination. Verify that the Bus Termination resistor jumper J43 is installed.</li> <li>• The NTS processor is not operating. Verify that the NTS MCU LED is flashing. If it is not flashing, replace the MAIN I/O board.</li> </ul>
NTS DT Limit Vel Flt	NTS Processor detected a car speed at the DT terminal limit that was greater than the clamp (parameter) speed	<ul style="list-style-type: none"> <li>• Verify that the limit activates at the correct location in the hoistway.</li> <li>• Verify the speed that the car hits the limit and adjust the limit velocity if necessary.</li> <li>• If the acceleration or deceleration rates were changed after the limit velocities were learned, the learn process may need to be repeated or the limit may need to be moved.</li> </ul>

Fault	Description	Possible Cause/Suggested Fix
NTS DT1 Limit Vel Flt	NTS Processor detected a car speed at the DT1 terminal limit that was greater than the clamp (parameter) speed	<ul style="list-style-type: none"> <li>• Verify that the limit activates at the correct location in the hoistway.</li> <li>• Verify the speed that the car hits the limit and adjust the limit velocity if necessary.</li> <li>• If the acceleration or deceleration rates were changed after the limit velocities were learned, the learn process may need to be repeated or the limit may need to be moved.</li> </ul>
NTS DT2 Limit Vel Flt	NTS Processor detected a car speed at the DT2 terminal limit that was greater than the clamp (parameter) speed	<ul style="list-style-type: none"> <li>• Verify that the limit activates at the correct location in the hoistway.</li> <li>• Verify the speed that the car hits the limit and adjust the limit velocity if necessary.</li> <li>• If the acceleration or deceleration rates were changed after the limit velocities were learned, the learn process may need to be repeated or the limit may need to be moved.</li> </ul>
NTS DT3 Limit Vel Flt	NTS Processor detected a car speed at the DT3 terminal limit that was greater than the clamp (parameter) speed	<ul style="list-style-type: none"> <li>• Verify that the limit activates at the correct location in the hoistway.</li> <li>• Verify the speed that the car hits the limit and adjust the limit velocity if necessary.</li> <li>• If the acceleration or deceleration rates were changed after the limit velocities were learned, the learn process may need to be repeated or the limit may need to be moved.</li> </ul>
NTS DT4 Limit Vel Flt	NTS Processor detected a car speed at the DT terminal limit that was greater than the clamp (parameter) speed	<ul style="list-style-type: none"> <li>• Verify that the limit activates at the correct location in the hoistway.</li> <li>• Verify the speed that the car hits the limit and adjust the limit velocity if necessary.</li> <li>• If the acceleration or deceleration rates were changed after the limit velocities were learned, the learn process may need to be repeated or the limit may need to be moved.</li> </ul>

Fault	Description	Possible Cause/Suggested Fix
NTS DT5 Limit Vel Flt	NTS Processor detected a car speed at the DT5 terminal limit that was greater than the clamp (parameter) speed	<ul style="list-style-type: none"> <li>• Verify that the limit activates at the correct location in the hoistway.</li> <li>• Verify the speed that the car hits the limit and adjust the limit velocity if necessary.</li> <li>• If the acceleration or deceleration rates were changed after the limit velocities were learned, the learn process may need to be repeated or the limit may need to be moved.</li> </ul>
NTS DT6 Limit Vel Flt	NTS Processor detected a car speed at the DT6 terminal limit that was greater than the clamp (parameter) speed	<ul style="list-style-type: none"> <li>• Verify that the limit activates at the correct location in the hoistway.</li> <li>• Verify the speed that the car hits the limit and adjust the limit velocity if necessary.</li> <li>• If the acceleration or deceleration rates were changed after the limit velocities were learned, the learn process may need to be repeated or the limit may need to be moved.</li> </ul>
NTS Enc Opp Dir Flt	NTS Processor Encoder Direction from the selector or from the Motor Encoder is opposite of the UP or DNR run direction.	<ul style="list-style-type: none"> <li>• Make sure that the elevator is running in the proper direction before attempting to correct this fault.</li> <li>• With an APS selector: <ul style="list-style-type: none"> <li>The camera may not be adjusted properly and no direction is indicated. Verify that the camera is mounted correctly.</li> <li>The camera may not be communicating with the Selector. Use the Diagnostic menu to verify that the Selector is communicating with the camera.</li> <li>The NTS Processor may not be communicating on the Safety CAN bus. Using the Diagnostic menu, verify that the NTS processor is communicating to the Selector and the Safety Processor on the Safety CAN Bus.</li> </ul> </li> <li>• With a Tapeless selector, the parameter for the NTS Processor Adjustable Variable -&gt; Velocity Dir must be changed to the opposite value, i.e. 1 to a 0 or 0 to a 1.</li> </ul>

Fault	Description	Possible Cause/Suggested Fix
<p>NTS Fault Dn Dir Run</p>	<p>NTS Fault Down Direction Run. The NTS processor hit a normal terminal limit going down at a velocity greater than the limit velocity parameter. This error is detected by the main CPU when the NTSDi input turns off during a run. Check the fault log for an MRCAN Device Fault showing the specific limit fault that occurred.</p>	<ul style="list-style-type: none"> <li>• If the NTSDi input does not turn on after the car stops, there may be a faulty NTSD input chip. Verify that the NTSD outputs are on and if so, replace the NTSDi input chip.</li> <li>• If the NTSD outputs are not on after the car stops, check the status of the output of NTSD on the Inputs and Outputs display for the NTS processor. If the LCD Display Interface shows that the NTS processor has the outputs on but the NTSD LEDs are not on, then there may be a faulty NTSD output chip. Replace the NTSD chip that has its corresponding LED off.</li> <li>• Verify that the limit activates at the correct location in the hoistway.</li> <li>• Verify the speed that the car hits the limit and adjust the limit velocity if necessary.</li> <li>• If the acceleration or deceleration rates were changed after the limit velocities were learned, the learn process may need to be repeated or the limit may need to be moved.</li> </ul>
<p>NTS Fault Up Dir Run</p>	<p>NTS Fault Up Direction Run. The NTS processor hit a normal terminal limit going up at a velocity greater than the limit velocity parameter. This error is detected by the main CPU when the NTSDi input turns off during a run. Check the fault log for an MRCAN Device Fault showing the specific limit fault that occurred.</p>	<ul style="list-style-type: none"> <li>• If the NTSDi input does not turn on after the car stops, there may be a faulty NTSD input chip. Verify that the NTSD outputs are on and if so, replace the NTSDi input chip.</li> <li>• If the NTSD outputs are not on after the car stops, check the status of the output of NTSD on the Inputs and Outputs display for the NTS processor. If the LCD Display Interface shows that the NTS processor has the outputs on but the NTSD LEDs are not on, then there may be a faulty NTSD output chip. Replace the NTSD chip that has its corresponding LED off.</li> <li>• Verify that the limit activates at the correct location in the hoistway.</li> <li>• Verify the speed that the car hits the limit and adjust the limit velocity if necessary.</li> <li>• If the acceleration or deceleration rates were changed after the limit velocities were learned, the learn process may need to be repeated or the limit may need to be moved.</li> </ul>

Fault	Description	Possible Cause/Suggested Fix
NTS Limit Vel Fault	NTS Limit Velocity Fault. During a limit learn, the velocity for one of the limits was recorded at a speed greater than the contract speed of the car. The velocity value of the limit is set to contract speed - 1.	<ul style="list-style-type: none"> <li>• View all the limit velocity values of the NTS processor. If a limit velocity value is set to contract speed - 1, then the limit may need to be moved closer to the terminal landing so that the car hits the limit at a slower speed.</li> </ul> <p><b>NOTE:</b> The controller sets the velocity at car speed -1 during the limit learn if something is not right with the limit.</p> <ul style="list-style-type: none"> <li>• Verify the velocity of the NTS processor during a normal run.</li> <li>• If the velocity value is correct, there could be enough of a delay that the car has started the slowdown but the velocity value has not been updated for the NTS processor. Try moving the limits closer to the terminal landing.</li> <li>• If using a tape selector, the velocity value that the NTS processor uses comes from the selector CPU. This value should also match the speed of the main CPU. Verify the proper pulse signals going into and out of the selector.</li> <li>• If using a tapeless selector, the NTS processor calculates the velocity from the motor encoder pulses. The velocity value will need to be adjusted to match the actual car speed. Increase the NTS RPM parameter value to reduce the NTS velocity or reduce the RPM to increase the NTS velocity.</li> </ul>
NTS Low Velocity Flt	NTS velocity < 25 fpm when car speed > 100 fpm for 3 seconds	<ul style="list-style-type: none"> <li>• The NTS velocity is much lower than controller velocity during an automatic run. This fault will cause an emergency slowdown if the NTS velocity is low for 3 seconds.</li> <li>• The NTS processor get its velocity from the selector. Verify the NTS communications to the selector.</li> </ul>
NTS SEL Comm Fault	NTS Processor recorded a communications fault with the Selector on the Safety CAN bus port.	<ul style="list-style-type: none"> <li>• Faulty CAN bus wiring.</li> <li>• Termination resistors are usually placed at the far end of each BUS. Verify the placement of the Termination resistors.</li> <li>• Try moving the termination resistors to other locations.</li> <li>• Faulty device, replace board.</li> </ul>



Fault	Description	Possible Cause/Suggested Fix
NTS SPB Comm Fault	NTS Processor recorded a communications fault with the Safety Processor on the Safety CAN bus port.	<ul style="list-style-type: none"> <li>• Faulty CAN bus wiring.</li> <li>• Termination resistors are usually placed at the far end of each BUS. Verify the placement of the Termination resistors.</li> <li>• Try moving the termination resistors to other locations.</li> <li>• Faulty device, replace board.</li> </ul>
NTS UT Limit Vel Flt	NTS Processor detected a car speed at the UT terminal limit that was greater than the clamp (parameter) speed	<ul style="list-style-type: none"> <li>• Verify that the limit activates at the correct location in the hoistway.</li> <li>• Verify the speed that the car hits the limit and adjust the limit velocity if necessary.</li> <li>• If the acceleration or deceleration rates were changed after the limit velocities were learned, the learn process may need to be repeated or the limit may need to be moved.</li> </ul>
NTS UT1 Limit Vel Flt	NTS Processor detected a car speed at the UT1 terminal limit that was greater than the clamp (parameter) speed	<ul style="list-style-type: none"> <li>• Verify that the limit activates at the correct location in the hoistway.</li> <li>• Verify the speed that the car hits the limit and adjust the limit velocity if necessary.</li> <li>• If the acceleration or deceleration rates were changed after the limit velocities were learned, the learn process may need to be repeated or the limit may need to be moved.</li> </ul>
NTS UT2 Limit Vel Flt	NTS Processor detected a car speed at the UT2 terminal limit that was greater than the clamp (parameter) speed	<ul style="list-style-type: none"> <li>• Verify that the limit activates at the correct location in the hoistway.</li> <li>• Verify the speed that the car hits the limit and adjust the limit velocity if necessary.</li> <li>• If the acceleration or deceleration rates were changed after the limit velocities were learned, the learn process may need to be repeated or the limit may need to be moved.</li> </ul>

Fault	Description	Possible Cause/Suggested Fix
NTS UT3 Limit Vel Flt	NTS Processor detected a car speed at the UT3 terminal limit that was greater than the clamp (parameter) speed	<ul style="list-style-type: none"> <li>• Verify that the limit activates at the correct location in the hoistway.</li> <li>• Verify the speed that the car hits the limit and adjust the limit velocity if necessary.</li> <li>• If the acceleration or deceleration rates were changed after the limit velocities were learned, the learn process may need to be repeated or the limit may need to be moved.</li> </ul>
NTS UT4 Limit Vel Flt	NTS Processor detected a car speed at the UT4 terminal limit that was greater than the clamp (parameter) speed	<ul style="list-style-type: none"> <li>• Verify that the limit activates at the correct location in the hoistway.</li> <li>• Verify the speed that the car hits the limit and adjust the limit velocity if necessary.</li> <li>• If the acceleration or deceleration rates were changed after the limit velocities were learned, the learn process may need to be repeated or the limit may need to be moved.</li> </ul>
NTS UT5 Limit Vel Flt	NTS Processor detected a car speed at the UT5 terminal limit that was greater than the clamp (parameter) speed	<ul style="list-style-type: none"> <li>• Verify that the limit activates at the correct location in the hoistway.</li> <li>• Verify the speed that the car hits the limit and adjust the limit velocity if necessary.</li> <li>• If the acceleration or deceleration rates were changed after the limit velocities were learned, the learn process may need to be repeated or the limit may need to be moved.</li> </ul>
NTS UT6 Limit Vel Flt	NTS Processor detected a car speed at the UT6 terminal limit that was greater than the clamp (parameter) speed	<ul style="list-style-type: none"> <li>• Verify that the limit activates at the correct location in the hoistway.</li> <li>• Verify the speed that the car hits the limit and adjust the limit velocity if necessary.</li> <li>• If the acceleration or deceleration rates were changed after the limit velocities were learned, the learn process may need to be repeated or the limit may need to be moved.</li> </ul>
NTS Vel Learn Fault	Invalid NTS velocity while learning Hoistway or Limits	<ul style="list-style-type: none"> <li>• NTS velocity did not match controller speed while learning hoistway or limits. The NTS processor get its velocity from the selector.</li> <li>• Verify communications to the selector.</li> </ul>

Fault	Description	Possible Cause/Suggested Fix
NTSD Comm Fault (From SEL)	Selector recorded a communications fault with the NTS Processor on the Safety CAN bus port.	<ul style="list-style-type: none"> <li>• Faulty CAN bus wiring.</li> <li>• Termination resistors are usually placed at the far end of each BUS. Verify the placement of the Termination resistors.</li> <li>• Try moving the termination resistors to other locations.</li> <li>• Faulty device, replace board.</li> </ul> <p><b>See: SEL NTSD Comm Fault</b></p>
NTSD Comm Fault (From SPB)	Safety Processor recorded a communications fault with the NTS Processor on the Safety CAN bus port.	<ul style="list-style-type: none"> <li>• Faulty CAN bus wiring.</li> <li>• Termination resistors are usually placed at the far end of each BUS. Verify the placement of the Termination resistors.</li> <li>• Try moving the termination resistors to other locations.</li> <li>• Faulty device, replace board.</li> </ul> <p><b>See: SPB NTSD Comm Fault</b></p>
Overspeed Fault	Car overspeed fault. If the car goes 15% over contract speed the fault will be logged and the car will do an emergency stop. This fault will set the gripper or emergency brake if parameter Car Options -> Griper/EBK Trip is set to +2.	<p>Encoder PPR incorrectly set. Set to match the Drive's Encoder Pulses.</p> <ul style="list-style-type: none"> <li>• Encoder RPM incorrectly set. Set to match the Motor's RPM.</li> </ul> <p>The drive is not controlling the hoist machine motor. Check the response setting on the drive.</p>
P Input Off Fault	The normally closed contacts on MC, BRK or RUN contactors did not drop.	<ul style="list-style-type: none"> <li>• Not enough current draw through all three contacts. Place a 10K 3W resistor from the normally closed contact of RUN to GND.</li> <li>• Faulty normally closed contacts on MC, BK or RUN. Replace auxiliary contacts.</li> </ul>

Fault	Description	Possible Cause/Suggested Fix
P Input On Fault	The 'P' input did not drop out while the car was running. This input should drop out when MC, BRK and Run contactors are energized.	Faulty contactor or auxiliary contacts on MC, BRK, or RUN. Replace auxiliary contacts or entire contactor
P1 APS Sel CAN Flt	Processor 1 on the APS Selector interface board is not communicating with the APS camera head on channel B.	<ul style="list-style-type: none"> <li>• Verify the RJ-45 connector from the selector camera to the selector interface board GALX-1133 is properly connected.</li> <li>• Verify that both LED's on the RJ-45 connector are blinking at 1 second intervals.</li> <li>• Make sure the CAT-6 cable is not run in parallel with any high voltage wires.</li> <li>• Replace the GALX-1133 board.</li> <li>• Replace the camera head.</li> </ul> <p><b>See: APS P1 Camera CAN Flt</b></p>
P1 APS Vel Check Flt	Processor 1 on the APS Selector interface board detected a Velocity Check fault between channel A and channel B.	<ul style="list-style-type: none"> <li>• Verify that both camera heads are clean, aligned and have a good contrast ratio (see Diagnostic menu)</li> <li>• Check for communications errors for the camera head to the selector interface board GALX-1133</li> </ul> <p><b>See: APS P1 Vel Check Flt</b></p>
P1 DN Input Fault	Processor 1 on the APS Selector interface board detected a Down Normal Limit input fault.	<ul style="list-style-type: none"> <li>• Processor 1 detected that the input for DN was off when the output was being turned on.</li> <li>• Faulty input, replace the input device.</li> <li>• Faulty output for DN. Replace the output device.</li> </ul> <p><b>See: APS P1 DN Input Fault</b></p>

Fault	Description	Possible Cause/Suggested Fix
P1 DZ Clip Fault	Processor 1 on the APS Selector interface board detected a door zone clip missing.	<ul style="list-style-type: none"> <li>• Processor 1 detected a door zone clip missing at the same floor for three consecutive stops on channel B.</li> <li>• Verify that the door zone clip is roughly in the middle of channel A and B cameras. Place the clip in the proper position</li> <li>• If the clip is missing or broken, then replace the clip.</li> <li>• Go to the LCD Interface on the Main CPU and select the Dpy APS Sel Valid Clips menu under the Hoistway Tables menu. Under the display for ClpP1, a bit is set for each floor with a valid clip. Position the elevator at the floor that does not have the bit set and re-learn the floor position.</li> </ul> <p><b>See: APS P1 DZ Clip Fault</b></p>
P1 DZ Input Fault	Processor 1 on the APS Selector interface board detected a door zone input fault.	<ul style="list-style-type: none"> <li>• Processor 1 detected that the input for DZ was off when the output was being turned on.</li> <li>• Faulty input, replace the input device.</li> <li>• Faulty output for DZ. Replace the output device.</li> </ul> <p><b>See: APS P1 DZ Input Fault</b></p>
P1 HoistW Floor Flt	Processor 1 on the APS Selector interface board has a hoistway learn flag set but does not have a valid floor table.	<ul style="list-style-type: none"> <li>• If the installation process to learn all the floors is not complete then then ignore this error.</li> <li>• Complete the learn process.</li> <li>• Go to the LCD Interface on the Main CPU and select the Dpy APS Sel Valid Floors menu under the Hoistway Tables menu. Under the display for FLRP1, a bit is set for each valid floor. Position the elevator at the floor that does not have the bit set and re-learn the floor position.</li> </ul> <p><b>See: APS P1 HW Floor Flt</b></p>
P1 HoistW Flr Cnt Er	Processor 1 on the APS Selector interface board has a floor count on a floor that is higher than the floor above.	<ul style="list-style-type: none"> <li>• If the installation process to learn all the floors is not complete then then ignore this error.</li> <li>• Complete the learn process.</li> <li>• Go to the LCD Interface on the Main CPU and select the Dpy APS Sel Valid Floors menu under the Hoistway Tables menu. Under the display for FLRP1, a bit is set for each valid floor. Position the elevator at the floor that does not have the bit set and re-learn the floor position.</li> </ul> <p><b>See: APS P1 HW Flr Cnt Er</b></p>

Fault	Description	Possible Cause/Suggested Fix
P1 HoistW Flr Cnt=0	Processor 1 on the APS Selector interface board has a hoistway floor count value that is zero.	<ul style="list-style-type: none"> <li>• If the installation process to learn all the floors is not complete then then ignore this error.</li> <li>• Complete the learn process.</li> <li>• Go to the LCD Interface on the Main CPU and select the Dpy APS Sel Valid Floors menu under the Hoistway Tables menu. Under the display for FLRP1, a bit is set for each valid floor. Position the elevator at the floor that does not have the bit set and re-learn the floor position.</li> </ul> <p><b>See: APS P1 HW Flr Cnt=0</b></p>
P1 HoistW Setup Flt	Processor 1 on the APS Selector interface board has a hoistway setup fault.	<ul style="list-style-type: none"> <li>• If the installation process to learn all the floors is not complete then then ignore this error.</li> <li>• Complete the learn process.</li> <li>• Go to the LCD Interface on the Main CPU and select the Dpy APS Sel Valid Floors menu under the Hoistway Tables menu. Under the display for FLRP1, a bit is set for each valid floor. Position the elevator at the floor that does not have the bit set and re-learn the floor position.</li> </ul> <p><b>See: APS P1 HW Setup Flt</b></p>
P1 Hoistway Initialized	APS Selector Processor 2 Hoistway Initialized for first time.	<ul style="list-style-type: none"> <li>• Should only occur on first time power up.</li> <li>• If this errors occurs on every power up then replace the board.</li> </ul> <p><b>See: APS P1 Hoistway Init</b></p>
P1 Prog Cmd Diff Flt	Processor 1 returned a different command than what was sent from Processor 2.	<ul style="list-style-type: none"> <li>•Verify that both MCU LEDs are blinking on the APS selector interface board.</li> <li>•Verify that the COMSPI LED driven by Processor 2 is blinking on the APS selector interface board.</li> </ul> <p><b>See: APS P1 Cmd Diff</b></p>
P1 Prog Flr Cnt Diff	Processor 1 returned a different floor count than what was sent from Processor 2.	<ul style="list-style-type: none"> <li>•Verify that both MCU LEDs are blinking on the APS selector interface board.</li> <li>•Verify that the COMSPI LED driven by Processor 2 is blinking on the APS selector interface board.</li> </ul> <p><b>See: APS P1 Prg Flr Cnt Dif</b></p>

Fault	Description	Possible Cause/Suggested Fix
P1 Prog Flr Diff Flt	Processor 1 returned a different floor number than what was sent from Processor 2.	<ul style="list-style-type: none"> <li>• Verify that both MCU LEDs are blinking on the APS selector interface board.</li> <li>• Verify that the COMSPI LED driven by Processor 2 is blinking on the APS selector interface board.</li> </ul> <p><b>See: APS P1 Prog Flr Diff</b></p>
P1 Prog Time-Out Flt	Processor 1 did not respond to Processor 2 within the required time during a floor count upload.	<ul style="list-style-type: none"> <li>• Verify that both MCU LEDs are blinking on the APS selector interface board.</li> <li>• Verify that the COMSPI LED driven by Processor 2 is blinking on the APS selector interface board.</li> </ul> <p><b>See: APS P1 Prog Time-Out</b></p>
P1 SS Input Fault	Processor 1 on the APS Selector interface board detected a Selector Safe input fault.	<ul style="list-style-type: none"> <li>• Processor 1 detected that the input for SS (Note: This refers to <b>SOK</b> and not <b>SOK1</b>) was off when the output was being turned on.</li> <li>• Faulty input, replace the input device.</li> <li>• Faulty Selector Safe Relay. Replace the relay.</li> </ul> <p><b>See: APS P1 SS Input Fault</b></p>
P1 SS Open Fault	Processor 1 on the APS Selector interface board detected that Selector Safe Relay output is open (off).	<ul style="list-style-type: none"> <li>• Processor 1 detected that the input SS is off.</li> <li>• The device has a fault condition. Check other APS fault codes and correct the condition.</li> <li>• Faulty Selector Safe Relay. Replace the relay.</li> </ul> <p><b>See: APS P1 SS Open Fault</b></p>
P1 UN Input Fault	Processor 1 on the APS Selector interface board detected a Up Normal Limit input fault.	<ul style="list-style-type: none"> <li>• Processor 1 detected that the input for UN was off when the output was being turned on.</li> <li>• Faulty input, replace the input device.</li> <li>• Faulty output for UN. Replace the output device.</li> </ul> <p><b>See: APS P1 UN Input Fault</b></p>
P2 APS Sel CAN Flt	Processor 2 on the APS Selector interface board is not communicating with the APS camera head on channel B.	<ul style="list-style-type: none"> <li>• Verify the RJ-45 connector from the selector camera to the selector interface board GALX-1133 is properly connected.</li> <li>• Verify that both LED's on the RJ-45 connector are blinking at 1 second intervals.</li> <li>• Make sure the CAT-6 cable is not run in parallel with any high voltage wires.</li> <li>• Replace the GALX-1133 board.</li> <li>• Replace the camera head.</li> </ul> <p><b>See: APS P2 Camera CAN Flt</b></p>

Fault	Description	Possible Cause/Suggested Fix
P2 DN Input Fault	Processor 2 on the APS Selector interface board detected a Down Normal Limit input fault.	<ul style="list-style-type: none"> <li>• Processor 2 detected that the input for DN was off when the output was being turned on.</li> <li>• Faulty input, replace the input device.</li> <li>• Faulty output for DN. Replace the output device.</li> </ul> <p><b>See: APS P2 DN Input Fault</b></p>
P2 DZ Clip Fault	Processor 2 on the APS Selector interface board detected a door zone clip missing.	<ul style="list-style-type: none"> <li>• Processor 2 detected a door zone clip missing at the same floor for three consecutive stops on channel B.</li> <li>• Verify that the door zone clip is roughly in the middle of channel A and B cameras. Place the clip in the proper position</li> <li>• If the clip is missing or broken, then replace the clip.</li> <li>• Go to the LCD Interface on the Main CPU and select the Dpy APS Sel Valid Clips menu under the Hoistway Tables menu. Under the display for ClpP2, a bit is set for each floor with a valid clip. Position the elevator at the floor that does not have the bit set and re-learn the floor position.</li> </ul> <p><b>See: APS P2 DZ Clip Fault</b></p>
P2 DZ Input Fault	Processor 2 on the APS Selector interface board detected a door zone input fault.	<ul style="list-style-type: none"> <li>• Processor 2 detected that the input for DZ was off when the output was being turned on.</li> <li>• Faulty input, replace the input device.</li> <li>• Faulty output for DZ. Replace the output device.</li> </ul> <p><b>See: APS P2 DZ Input Fault</b></p>
P2 FVars Initialized	APS Selector Processor 2 Field Variables Initialized for first time.	<ul style="list-style-type: none"> <li>• Should only occur on first time power up.</li> <li>• If this errors occurs on every power up then replace the board.</li> </ul> <p><b>See: APS P2 Fvars Init</b></p>



Fault	Description	Possible Cause/Suggested Fix
P2 HoistW Floor Flt	Processor 2 on the APS Selector interface board has a hoistway learn flag set but does not have a valid floor table.	<ul style="list-style-type: none"> <li>• If installation process to learn all the floors is not complete then then ignore this error.</li> <li>• Complete the learn process.</li> <li>• Go to the LCD Interface on the Main CPU and select the Dpy APS Sel Valid Floors menu under the Hoistway Tables menu. Under the display for FLRP2, a bit is set for each valid floor. Position the elevator at the floor that does not have the bit set and re-learn the floor position.</li> </ul> <p><b>See: APS P2 HW Floor Flt</b></p>
P2 HoistW Flr Cnt Er	Processor 2 on the APS Selector interface board has a floor count on a floor that is higher than the floor above.	<ul style="list-style-type: none"> <li>• If installation process to learn all the floors is not complete then then ignore this error.</li> <li>• Go to the LCD Interface on the Main CPU and select the Dpy APS Sel Valid Floors menu under the Hoistway Tables menu. A bit is set for each valid floor. Position the elevator at the floor that does not have the bit set and re-learn the floor position.</li> </ul> <p><b>See: APS P2 HW Flr Cnt Er</b></p>
P2 HoistW Flr Cnt=0	Processor 2 on the APS Selector interface board has a hoistway floor count value that is zero.	<ul style="list-style-type: none"> <li>• If installation process to learn all the floors is not complete then then ignore this error.</li> <li>• Complete the learn process.</li> <li>• Go to the LCD Interface on the Main CPU and select the Dpy APS Sel Valid Floors menu under the Hoistway Tables menu. Under the display for FLRP2, a bit is set for each valid floor. Position the elevator at the floor that does not have the bit set and re-learn the floor position.</li> </ul> <p><b>See: APS P2 HW Flr Cnt=0</b></p>
P2 HoistW Setup Flt	Processor 2 on the APS Selector interface board has a hoistway setup fault.	<ul style="list-style-type: none"> <li>• If the installation process to learn all the floors is not complete then then ignore this error.</li> <li>• Complete the learn process.</li> <li>• Go to the LCD Interface on the Main CPU and select the Dpy APS Sel Valid Floors menu under the Hoistway Tables menu. Under the display for FLRP2, a bit is set for each valid floor. Position the elevator at the floor that does not have the bit set and re-learn the floor position.</li> </ul> <p><b>See: APS P2 HW Setup Flt</b></p>

Fault	Description	Possible Cause/Suggested Fix
P2 Hoistway Initialized	APS Selector Processor 2 Hoistway Initialized for first time.	<ul style="list-style-type: none"> <li>• Should only occur on first time power up.</li> <li>• If this errors occurs on every power up then replace the board.</li> </ul> <p><b>See: APS P2 Hoistway Init</b></p>
P2 SP CAN Com Fault	Processor 2 on the APS Selector interface board is not communicating on the SPCAN bus with the NTS processor or the Safety Processor.	<ul style="list-style-type: none"> <li>• Verify proper twisted pair wires to the SPCH and SPCL terminals on the GALX-1102 board.</li> <li>• Noise on the CAN Bus, verify that the shield wire is connected according to the job print.</li> </ul> <p><b>See: APS P2 SP CAN Com Flt</b></p>
P2 SPI Com Fault	Processor 2 is not communicating through the SPI serial port with Processor 1 on the APS Selector interface board.	<ul style="list-style-type: none"> <li>• Cycle the power on the board. If the problem persist, replace the APS board.</li> </ul> <p><b>See: APS P2 SPI Com Flt</b></p>
P2 SS Input Fault	Processor 2 on the APS Selector interface board detected a Selector Safe input fault.	<ul style="list-style-type: none"> <li>• Processor 2 detected that the input for SS (Note: This refers to <b>SOK</b> and not <b>SOK1</b>) was off when the output was being turned on.</li> <li>• Faulty input, replace the input device.</li> <li>• Faulty Selector Safe Relay. Replace the relay.</li> </ul> <p><b>See: APS P2 SS Input Fault</b></p>
P2 SS Open Fault	Processor 2 on the APS Selector interface board detected that Selector Safe Relay output is open (off).	<ul style="list-style-type: none"> <li>• Processor 2 detected that the input SS is off.</li> <li>• The device has a fault condition. Check other APS fault codes and correct the condition.</li> <li>• Faulty Selector Safe Relay. Replace the relay.</li> </ul> <p><b>See: APS P2 SS Open Fault</b></p>
P2 UN Input Fault	Processor 2 on the APS Selector interface board detected a Up Normal Limit input fault.	<ul style="list-style-type: none"> <li>• Processor 2 detected that the input for UN was off when the output was being turned on.</li> <li>• Faulty input, replace the input device.</li> <li>• Faulty output for UN. Replace the output device.</li> </ul> <p><b>See: APS P2 UN Input Fault</b></p>

Fault	Description	Possible Cause/Suggested Fix
PAL Error	The Safety PAL device did not pass the system test by the local CPU device.	<ul style="list-style-type: none"> <li>Faulty PAL or faulty board. Replace GALX-1102AN board.</li> </ul> <b>See: SAF PAL Error</b>
PAL ETS Dn Spd Flt	The Safety PAL detected a car speed at the ETS Down terminal limit that was greater than the clamp speed.	<ul style="list-style-type: none"> <li>Verify that the limit activates at the correct location in the hoistway.</li> <li>Verify the speed that the car hits the limit and adjust the limit velocity if necessary.</li> <li>If the acceleration or deceleration rates were changed after the limit velocities were learned, the learn process may need to be repeated or the limit may need to be moved.</li> <li>Verify the parameter setting in the Safety Processor for PAL ETS Dn Vel.</li> </ul> <b>See: SAF PAL ETS Dn Spd F</b>
PAL ETS Up Spd Flt	The Safety PAL detected a car speed at the ETS Up terminal limit that was greater than the clamp speed.	<ul style="list-style-type: none"> <li>Verify that the limit activates at the correct location in the hoistway.</li> <li>Verify the speed that the car hits the limit and adjust the limit velocity if necessary.</li> <li>If the acceleration or deceleration rates were changed after the limit velocities were learned, the learn process may need to be repeated or the limit may need to be moved.</li> <li>Verify the parameter setting in the Safety Processor for PAL ETS Up Vel.</li> </ul> <b>See: SAF PAL ETS Up Spd F</b>
Parameter Setup Fault	Safety Processor has a parameter setup fault	<ul style="list-style-type: none"> <li>Check the Safety Processor parameter settings for Buffer Type and Rear Door. Make sure they are set as required for the job.</li> </ul> <b>See: SPB Par Setup Fault</b>
PFC Relay Failed Off	PFC relay did not pick up as expected	<ul style="list-style-type: none"> <li>Faulty PFC output chip. Replace output chip.</li> <li>Faulty PFC relay on main I/O Board GALX-1102. Replace PFC relay.</li> </ul>
PFC Relay Failed On	PFC relay did not drop as expected when performing a SFC/PFC test.	<ul style="list-style-type: none"> <li>Faulty PFC output chip. Replace output chip.</li> <li>Faulty PFC relay on main I/O Board GALX-1102. Replace PFC relay.</li> </ul>

Fault	Description	Possible Cause/Suggested Fix
PFC-SFC Test Lost DZ	Lost DZ input when performing a SFC/PFC test.	<ul style="list-style-type: none"> <li>• DZ output on selector board did not turn on. (Replace DZ output on selector driver board).</li> <li>• One or both of the DZ sensors on the selector sensor board failed. Replace selector sensor board.</li> <li>• DZ input on the GALX-1102 board failed. Replace DZ input on the GALX-1102 board.</li> <li>• Check leveling magnet.</li> </ul>
Pit Door Switch Flt	Pit Door Switch Open	<ul style="list-style-type: none"> <li>• Verify that the pit door switch is closed.</li> <li>• Faulty wiring on the pit door switch circuit.</li> </ul>
Pit Switch Fault	Pit Switch Input Open	<ul style="list-style-type: none"> <li>• Verify that the pit switch is closed.</li> <li>• Faulty wiring on the pit switch circuit.</li> </ul>
Pls Er 75% Top Speed	Pulse Error occurred while car is running greater then 75% of contract speed. The pulse counts have to change a minimum distance by the time the car reaches 75% of top speed.	<ul style="list-style-type: none"> <li>• This error occurs if the car loses its pulse feedback from the encoder.</li> <li>• Make sure that the encoder is not slipping.</li> <li>• Check the encoder cable from the drive to the controller.</li> <li>• Also check the ribbon cable from the encoder isolation on the GALX-1102 board to the encoder input on the 1100 CPU board.</li> </ul>
Position Fault	The Terminal limits do not match the car position (UT or DT is hit but the car position is not at the top or bottom floor).	<ul style="list-style-type: none"> <li>• Car is out of step from faulty selector inputs. Check that the DZ, UL and DL selector inputs work properly at each floor.</li> <li>• Car missed a slowdown input magnet. Check that the US and DS selector inputs work properly prior to each landing (<b>Hydro</b>).</li> <li>• UT or DT input lost from the safety string being opened.</li> <li>• Improper adjustment of UT or DT limit switches</li> </ul>
Possible DRV/SPB Er	The controller CPU lost the stop switch input, but has the SS and GTS inputs ON indicating that the drive or Safety Processor board has opened the safety string.	<ul style="list-style-type: none"> <li>• View the faults on the Safety Processor display and debug from the fault code listed.</li> <li>• View the drive faults log or LED status and debug as directed from the drive manual.</li> </ul>

Fault	Description	Possible Cause/Suggested Fix
Power Up Reset	Whenever power is cycled on the controller this error will indicate that the controller CPU was reset	<ul style="list-style-type: none"> <li>• This error code is normal for a power loss. If power was not lost and the CPU re-boots, verify the +5VDC on the CPU power connector reads in the range of 4.90 and 5.1 VDC. If out of range, adjust the 5VDC supply pot for the correct voltage.</li> </ul>
Pulse Error > 75 fpm	Pulse count shows a travel distance less than 2 inches while the car demand velocity is greater than 75 fpm.	<ul style="list-style-type: none"> <li>• Make sure that the encoder is not slipping.</li> <li>• Check the ribbon cable from the encoder isolation on the GALX-1102 Main I/O board to the encoder connection on the GALX-1100 CPU board.</li> <li>• Possible faulty encoder isolation on Main I/O board, faulty ribbon cable or faulty encoder CPU board.</li> </ul>
Rail Lock Switch Flt	Rail Lock Safety Switch Input is not on when expected.	<ul style="list-style-type: none"> <li>• Check the rail lock contact on the COP board.</li> <li>• Faulty RLS input. Replace the input.</li> <li>• If there is no rail lock device (required for MRL elevators) this input may need to be jumped.</li> </ul>
RCM / Lock Flt	Retiring Cam/Lock fault. Job has door contacts and door lock inputs as well as retiring cam output. Door locks are not coming on when trying to leave the floor.	<ul style="list-style-type: none"> <li>• Door Contacts were already closed and the controller attempted to energize the retiring cam (RCM) several times and the door locks did not turn on. After 4 attempts, it will declare this fault. Check locks or retiring cam device.</li> </ul>
RDoor Close Cont Flt	Rear Door Close Contact safe fault	<ul style="list-style-type: none"> <li>• After Controller was safe with doors, gate switch, door contacts and locks made and ready to run, a door contact input turned OFF.</li> </ul>
Rear Bot Lock Fault	The Rear Bottom Door Lock failed on while the door was open (door on the rear door open limit [DOL]).	<p>Faulty door lock.</p> <ul style="list-style-type: none"> <li>• Jumper placed on door lock circuit.</li> <li>• Rear door lock not adjusted properly.</li> <li>• Faulty wiring to DLB input.</li> <li>• Faulty DLB and DLB-1 inputs (For this to occur both DLB and DLB-1 inputs must fail on).</li> <li>• DOLR input failed. Replace DOLR input chip.</li> <li>• Rear door operator open limit is not adjusted properly</li> </ul>

Fault	Description	Possible Cause/Suggested Fix
Rear Det Edge Fault	Rear Detector Edge Time-out	<ul style="list-style-type: none"> <li>• The Rear Electric Eye signal stayed on continuously for longer than the parameter 'EE Time-out' is set to.</li> </ul>
Rear Door Close Flt	The rear door did not reach the Rear Door Close Limit within the door close protection time.	<ul style="list-style-type: none"> <li>• Rear Door Close Limit (DCLR) not adjusted properly.</li> <li>• Faulty Rear Door Close Limit (DCLR). Replace DCRL input.</li> <li>• Trash in door track preventing door from closing.</li> </ul>
Rear Door Open Fault	The rear door did not reach the Rear Door Open Limit within the door open protection time.	<ul style="list-style-type: none"> <li>• Rear Door Open Limit (DOLR) not adjusted properly.</li> <li>• Faulty Rear Door Open Limit (DOLR). Replace DOLR input.</li> </ul>
Rear Gate Sw Fault	The Rear Gate Switch failed on while the door was open.	<ul style="list-style-type: none"> <li>• Rear Gate switch not adjusted properly.</li> <li>• RGS input failed on. Replace RGS input.</li> </ul>
Rear Mid Lock Fault	The Middle Door Lock failed on while the door was open.	<p>Faulty door lock.</p> <ul style="list-style-type: none"> <li>• Jumper placed on door lock circuit.</li> <li>• Rear door lock not adjusted properly.</li> <li>• Faulty wiring to RLM input.</li> <li>• Faulty RLM and RLM-1 inputs (For this to occur both RLM and RLM-1 inputs must fail on).</li> <li>• DOLR input failed. Replace DOLR input chip.</li> <li>• Rear door operator open limit is not adjusted properly</li> </ul>
Rear Top Lock Fault	The Rear Top Door Lock failed on while the door was open.	<p>Faulty door lock.</p> <ul style="list-style-type: none"> <li>• Jumper placed on door lock circuit.</li> <li>• Rear door lock not adjusted properly.</li> <li>• Faulty wiring to DLT input.</li> <li>• Faulty DLT and DLT-1 inputs (For this to occur both DLT and DLT-1 inputs must fail on).</li> <li>• DOLR input failed. Replace DOLR input chip.</li> <li>• Rear door operator open limit is not adjusted properly</li> </ul>

Fault	Description	Possible Cause/Suggested Fix
Reset Brown-out	Device Reset from Power Brown-out	<ul style="list-style-type: none"> <li>• Fault is enabled from LCD Interface menu Adjustable Variables then select NTS Proc Adj Vars or SPB Proc Adj Vars and set parameter Debug Mode = 1. This is used for engineering debugging only.</li> </ul>
Reset Debug Trap	Device Reset from Debug Trap	<ul style="list-style-type: none"> <li>• Fault is enabled from LCD Interface menu Adjustable Variables then select NTS Proc Adj Vars or SPB Proc Adj Vars and set parameter Debug Mode = 1. This is used for engineering debugging only.</li> </ul>
Reset Fault	<p>Anytime the system detects one of the following faults a reset fault is logged:</p> <ul style="list-style-type: none"> <li>• Power is cycled</li> <li>• Controller finds itself out of the door zone.</li> <li>• Binary input fault.</li> <li>• Terminal limits do not match the current position.</li> <li>• Car has been switched off of inspection.</li> <li>• After an open safety string has been closed.</li> </ul>	<ul style="list-style-type: none"> <li>• This fault is logged under normal conditions. Check the fault log for error that would indicate a fault condition prior to the reset fault.</li> </ul>
Reset Idle Clock	Device Reset from Clock Failure	<ul style="list-style-type: none"> <li>• Fault is enabled from LCD Interface menu Adjustable Variables then select NTS Proc Adj Vars or SPB Proc Adj Vars and set parameter Debug Mode = 1. This is used for engineering debugging only.</li> </ul>
Reset Illegal Op Code	Device Reset from Illegal Operation Code	<ul style="list-style-type: none"> <li>• Fault is enabled from LCD Interface menu Adjustable Variables then select NTS Proc Adj Vars or SPB Proc Adj Vars and set parameter Debug Mode = 1. This is used for engineering debugging only.</li> </ul>
Reset MCLR Error	Device Reset from MCLR Error	<ul style="list-style-type: none"> <li>• Fault is enabled from LCD Interface menu Adjustable Variables then select NTS Proc Adj Vars or SPB Proc Adj Vars and set parameter Debug Mode = 1. This is used for engineering debugging only.</li> </ul>

Fault	Description	Possible Cause/Suggested Fix
Reset Power-up	Normal Power up reset	<ul style="list-style-type: none"> <li>• Fault is enabled from LCD Interface menu Adjustable Variables then select NTS Proc Adj Vars or SPB Proc Adj Vars and set parameter Debug Mode = 1. This is used for engineering debugging only.</li> </ul>
Reset Sleep Wakeup	Device Reset from a Sleep Condition	<ul style="list-style-type: none"> <li>• Fault is enabled from LCD Interface menu Adjustable Variables then select NTS Proc Adj Vars or SPB Proc Adj Vars and set parameter Debug Mode = 1. This is used for engineering debugging only.</li> </ul>
Reset Software	Device Reset from a Software Reset	<ul style="list-style-type: none"> <li>• Fault is enabled from LCD Interface menu Adjustable Variables then select NTS Proc Adj Vars or SPB Proc Adj Vars and set parameter Debug Mode = 1. This is used for engineering debugging only.</li> </ul>
Reset Watch Dog Timeout	Device Reset from Watch Dog Time-out	<ul style="list-style-type: none"> <li>• Fault is enabled from LCD Interface menu Adjustable Variables then select NTS Proc Adj Vars or SPB Proc Adj Vars and set parameter Debug Mode = 1. This is used for engineering debugging only.</li> </ul>
RETST OFF Fault	Rear Door Electric Eye Test Failed OFF. Output is turned on cause the electric eye outputs to controller input EER1 and EER2 to pulse.	<ul style="list-style-type: none"> <li>• RETST output or RETST input failed in the on state.</li> <li>• Replace the RETST output chip.</li> <li>• Replace the RETST input chip.</li> </ul>
RETST ON Fault	Rear Door Electric Eye Test Failed ON. Output is turned on caused the electric eye outputs to controller input EER1 and EER2 to pulse.	<ul style="list-style-type: none"> <li>• RETST output or RETST input failed in the on state.</li> <li>• Replace the RETST output chip.</li> <li>• Replace the RETST input chip.</li> </ul>
RGS & RGS-1 Opposite	Input failure on one of the Rear Gate Switch (RGS) inputs.	<ul style="list-style-type: none"> <li>• Faulty RGS or RGS-1 input. Replace input chip.</li> </ul>



Fault	Description	Possible Cause/Suggested Fix
RLM & RLM-1 Opposite	Input failure on one of the Rear Lock Middle (RLM) inputs	<ul style="list-style-type: none"> <li>• Faulty RLM or RLM-1 input. Replace input chip.</li> </ul>
RLM open w/R Acc DLB	Rear Lock Middle open with Rear Access Door Lock Bottom is open at the bottom floor.	<ul style="list-style-type: none"> <li>• Incorrect door lock wiring. Wire according to the job schematic.</li> <li>• If access is enabled, verify that the correct lock is wired for the front or rear door that will open on access.</li> </ul>
RLM open w/R Acc DLT	Rear Lock Middle open with Rear Access Door Lock Top open at the top floor.	<ul style="list-style-type: none"> <li>• Incorrect door lock wiring. Wire according to the job schematic.</li> <li>• If access is enabled, verify that the correct lock is wired for the front or rear door that will open on access.</li> </ul>
RPM Input Fault	RPM Input Fault. The Rear Door Protection input stayed on when the rear door reached full open.	<ul style="list-style-type: none"> <li>• RPM switch not setup properly on the door operator.</li> <li>• Faulty RPM input.</li> <li>• Replace RPM input chip.</li> </ul>
RPM Off/RGS or DL On	RPM Off with Rear Gate Switch or Door Lock On. The Rear Door Protection Module input must go on before rear gate switch or door lock inputs go on.	<ul style="list-style-type: none"> <li>• The RPM switch on the door operator is not setup properly.</li> <li>• There is no RPM input on the door operator. Jump the RPM input to the RGS terminal.</li> <li>• Faulty RPM input. Replace the RPM input chip.</li> </ul>

Fault	Description	Possible Cause/Suggested Fix
Run Fault: Shutdown	<p>Run Fault: Shutdown. If the car attempts to run 4 consecutive times and incurs a specific type of emergency stop without making a successful run, the car is shutdown and this error code is shown. The specific types of emergency stops to cause this fault are as follows:</p> <ol style="list-style-type: none"> <li>1. The car has picked the brake and is in the run mode for more than 2 seconds and the position pulse has not changed.</li> <li>2. The car is demanding a velocity greater than 75 fpm and change in position</li> </ol>	<ul style="list-style-type: none"> <li>• Verify that the brake is lifting properly.</li> <li>• Verify that the encoder pulses increment and decrement when running up or down.</li> </ul>
RUN I/O Failed Off	<p>The RUN input or output has failed off.</p>	<p><b>Traction</b></p> <ul style="list-style-type: none"> <li>• Faulty wiring to RN1 terminal.</li> <li>• Faulty RUNi input. Replace the RUNi input chip.</li> <li>• Faulty RUN output. Replace the RUN output chip.</li> </ul> <p><b>Hydro</b></p> <ul style="list-style-type: none"> <li>• Faulty wiring at the SC terminal. Verify that the valve common SC terminal on the Main I/O board is connected properly.</li> <li>• Faulty RUNi input. Replace the RUNi input chip.</li> <li>• Faulty RUN output. Replace the RUN output chip.</li> </ul>

Fault	Description	Possible Cause/Suggested Fix
RUN I/O Failed On	The RUN input or output has failed on.	<p><b>Traction</b></p> <ul style="list-style-type: none"> <li>• Faulty wiring to RN1 terminal.</li> <li>• Faulty RUNi input. Replace the RUNi input chip.</li> <li>• Faulty RUN output. Replace the RUN output chip.</li> </ul> <p><b>Hydro</b></p> <ul style="list-style-type: none"> <li>• Faulty wiring at the SC terminal. Verify that the valve common SC terminal on the Main I/O board is connected properly.</li> <li>• Faulty RUNi input. Replace the RUNi input chip.</li> <li>• Faulty RUN output. Replace the RUN output chip.</li> </ul>
Run Inhibit Rset Cnt	Run inhibit from reset count	<ul style="list-style-type: none"> <li>• Once the car is in Reset mode, the controller attempted 5 times to come off reset but it keeps being sent back in reset.</li> </ul>
RUN O/RUN I Failed	RUN output failed off or RUNi input failed on	<ul style="list-style-type: none"> <li>• Faulty RUNi input chip. Replace input chip.</li> <li>• Faulty RUN output chip. Replace output chip.</li> </ul>
RUN O/RUNA I Failed	RUN output failed off or RUNAi input failed on	<ul style="list-style-type: none"> <li>• Faulty RUNAi input chip. Replace input chip.</li> <li>• Faulty RUN output chip. Replace output chip.</li> </ul>
RUN, RUNA, DNR Fail	The RUN input or output, the RUNA output or the DNR output failed to turn on.	<p><b>Hydro</b></p> <ul style="list-style-type: none"> <li>• Faulty wiring at the SC terminal. Verify that the valve common SC terminal on the Main I/O board is connected properly.</li> <li>• Faulty wiring at the SD terminal. Verify that the down valve is wired to the SD terminal on the Main I/O board.</li> <li>• Faulty SDi input (replace input chip).</li> <li>• Faulty SD output (replace output chip).</li> <li>• Faulty RUNi input. Replace the RUNi input chip.</li> <li>• Faulty RUN output. Replace the RUN output chip.</li> </ul>

Fault	Description	Possible Cause/Suggested Fix
RUN, RUNA, UP Fail	The RUN input or output, the RUNA output or the UP output failed to run on.	<p><b>Hydro</b></p> <ul style="list-style-type: none"> <li>• Faulty wiring at the SC terminal. Verify that the valve common SC terminal on the Main I/O board is connected properly.</li> <li>• Faulty wiring at the SU terminal. Verify that the down valve is wired to the SU terminal on the Main I/O board.</li> <li>• Faulty SUI input (replace input chip).</li> <li>• Faulty SU output (replace output chip).</li> <li>• Faulty RUNi input. Replace the RUNi input chip.</li> <li>• Faulty RUN output. Replace the RUN output chip.</li> </ul>
RUNA I/O Failed Off	The RUNA input or output has failed off.	<p><b>Traction</b></p> <ul style="list-style-type: none"> <li>• Fault on Safety Processor Board. This board Can disable the run control to the RUNA output chip. Check if the PIC or PAL inhibit LEDs are on or if they turn on when the car attempts to run. Check the elevator service, faults, and inputs/outputs on the Safety Processor Board LCD display.</li> <li>• Faulty RUNAi input. Replace the RUNAi input chip.</li> <li>• Faulty RUNA output. Replace the RUNA output chip.</li> </ul> <p><b>Hydro</b></p> <ul style="list-style-type: none"> <li>• Faulty wiring at the SC terminal. Verify that the valve common SC terminal on the Main I/O board is connected properly.</li> <li>• Faulty RUNAi input. Replace RUNAi input chip.</li> <li>• Faulty RUNA output. Replace RUNA output chip.</li> <li>• Faulty RUN output. Replace RUN output chip.</li> </ul>
RUNA I/O Failed On	The RUNA input or output has failed on	<p><b>Traction</b></p> <ul style="list-style-type: none"> <li>• Faulty RUNAi input. Replace the RUNAi input chip.</li> <li>• Faulty RUNA output. Replace the RUNA output chip.</li> </ul> <p><b>Hydro</b></p> <ul style="list-style-type: none"> <li>• Faulty wiring at the SC terminal. Verify that the valve common SC terminal on the Main I/O board is connected properly.</li> <li>• Faulty RUN output. Replace RUN output chip.</li> <li>• Faulty RUNAi input. Replace RUNAi input chip.</li> <li>• Faulty RUNA output. Replace RUNA output chip.</li> </ul>

Fault	Description	Possible Cause/Suggested Fix
RUNA O/RUN I Failed	RUNA output or RUNI input failed	<ul style="list-style-type: none"> <li>• RUNA output failed off. Replace the RUNA output chip. Or</li> <li>• RUNI input failed off. Replace the RUNI input chip.</li> </ul>
RUNX Failed Off	<p>RUNX relay contact Failed OFF. The RUNX relay coil is wired in parallel with the RUN relay. Only one contact is used and is in series with the enable on the drive. The contact is monitored by main CPU with the RUNX input.</p>	<ul style="list-style-type: none"> <li>• Verify that the RUNX relay is turning on as expected. The relay coil or the contact could be faulty. Replace the RUNX relay.</li> <li>• The RUNX LED should turn on when MC and RUNX relays turn on. If the RUNX LED does not turn on, manually pick the MC contactor and check for voltage on the CCFM terminal. If there is no voltage on CCFM, diagnose and correct the problem with the MC contactor.</li> <li>• Attempt to run the car on inspection and watch the RUNX LED. If the RUNX LED does not turn on the replace the RUNX relay.</li> <li>• Attempt to run the car on inspection and monitor the voltage on EN terminal. If the RUNX LED turns on and there is voltage on the EN terminal, replace the RUNX input chip.</li> </ul>
RUNX Failed On	<p>RUNX relay contact Failed ON. The RUNX relay coil is wired in parallel with the RUN relay. Only one contact is use and is in series with the enable on the drive. The contact is monitored by main CPU with the RUNX input.</p>	<ul style="list-style-type: none"> <li>• Verify that the RUNX relay is dropping out as expected. The relay coil or the contact could be faulty. Replace the RUNX relay.</li> <li>• The RUNX LED should be off when MC is off. If the RUNX LED remains on, check for voltage on the CCFM terminal. If there is voltage on CCFM, diagnose and correct the problem with the MC contactor.</li> <li>• If the RUNX LED is off, push the MC contactor in. If the RUNX LED turn off then the RUNX contact is stuck on. Replace the RUNX relay.</li> <li>• If the RUNX LED is off but the input shows on the main CPU input display, then replace the RUNX input chip.</li> </ul>

Fault	Description	Possible Cause/Suggested Fix
RUNX Off While Motion	<p>RUNX Off While Elevator is in Motion. The RUNX contact is tested at the start of a run but is also expected to remain energized during the entire run.</p>	<ul style="list-style-type: none"> <li>• The MC contactor could have dropped unexpectedly. Run the car again and monitor the status of the MC contactor. Usually you would get an MCX input off fault if this occurs.</li> <li>• Monitor the 24 VDC at the CCFM input. If the 24 VDC drops during the run then the MC auxiliary contact is bad. Replace the contact.</li> <li>• Monitor the RUNX LED during a run. If the LED turns off then the RUNX relay is possible faulty. Replace the RUNX relay.</li> <li>• Check for other faults in the fault log during the same time period. If the RUN relay is also dropping, the fault is most likely caused by something in the RUN circuit. Check for RUN or RUNA I/O Faults.</li> </ul>
S10 Fuse Blown Fault	<p>The S10 input is off. No Power on S10</p>	<ul style="list-style-type: none"> <li>• There is a short from S10 to GND.</li> </ul>
SAF PAL Error	<p>The Safety PAL device did not pass the system test by the local CPU device.</p>	<ul style="list-style-type: none"> <li>• Faulty PAL or faulty board. Replace GALX-1102AN board.</li> </ul>
SAF PAL ETS Dn Spd F	<p>The Safety PAL detected a car speed at the ETS Down terminal limit that was greater than the clamp speed.</p>	<ul style="list-style-type: none"> <li>• Verify that the limit activates at the correct location in the hoistway.</li> <li>• Verify the speed that the car hits the limit and adjust the limit velocity if necessary.</li> <li>• If the acceleration or deceleration rates were changed after the limit velocities were learned, the learn process may need to be repeated or the limit may need to be moved.</li> <li>• Verify the parameter setting in the Safety Processor for PAL ETS Dn Vel.</li> </ul>

Fault	Description	Possible Cause/Suggested Fix
SAF PAL ETS Up Spd F	<p>The Safety PAL detected a car speed at the ETS Up terminal limit that was greater than the clamp speed.</p>	<ul style="list-style-type: none"> <li>• Verify that the limit activates at the correct location in the hoistway.</li> <li>• Verify the speed that the car hits the limit and adjust the limit velocity if necessary.</li> <li>• If the acceleration or deceleration rates were changed after the limit velocities were learned, the learn process may need to be repeated or the limit may need to be moved.</li> <li>• Verify the parameter setting in the Safety Processor for PAL ETS Up Vel.</li> </ul>
Safety String Fault	<p>Safety string fault occurs from the following conditions:</p> <ul style="list-style-type: none"> <li>• The safety string is open (SS input is off).</li> <li>• The drive ready input is not energized from the drive.</li> <li>• The potential to run input 'P' is off.</li> </ul>	<ul style="list-style-type: none"> <li>• The safety string is open (SS input is off). Refer to the job prints and check all circuits before the SS input.</li> </ul>
SEB CAN Com Error	<p>Serial Expansion Board Can Communications Error. One of the Serial Expansion boards is not communicating with the main CPU.</p>	<ul style="list-style-type: none"> <li>• From the LCD user interface, select the Diagnostic menu and then the Car Com Status menu. The device that is not communicating will be shown with the online status equal 0.</li> <li>• Check the terminal connection for the twisted pair wires.</li> </ul>
SEL CAN Com Error	<p>Top of car selector board communication error.</p>	<ul style="list-style-type: none"> <li>• From the LCD user interface, select the Diagnostic menu and then the Car Com Status menu. If the selector board is not communicating it will show with the online status equal to 0.</li> <li>• Check the terminal connection for the twisted pair wires. Verify that CANH and CANL on the selector board are wired to CANH and CANL to the top of car board respectively.</li> </ul>

Fault	Description	Possible Cause/Suggested Fix
SEL Comm Fault (From NTS)	NTS Processor recorded a communications fault with the Selector on the Safety CAN bus port.	<ul style="list-style-type: none"> <li>• Faulty CAN bus wiring.</li> <li>• Termination resistors are usually placed at the far end of each BUS. Verify the placement of the Termination resistors.</li> <li>• Try moving the termination resistors to other locations.</li> <li>• Faulty device, replace board.</li> </ul> <p><b>See: NTS SEL Comm Fault</b></p>
SEL Comm Fault (From SPB)	Safety Processor recorded a communications fault with the Selector on the Safety CAN bus port.	<ul style="list-style-type: none"> <li>• Faulty CAN bus wiring.</li> <li>• Termination resistors are usually placed at the far end of each BUS. Verify the placement of the Termination resistors.</li> <li>• Try moving the termination resistors to other locations.</li> <li>• Faulty device, replace board.</li> </ul> <p><b>See: SPB SEL Comm Fault</b></p>
SEL Dev CAN Fault	Selector not communicating to the main CPU.	<ul style="list-style-type: none"> <li>• Faulty Can communication wire connection. Verify proper twisted pair wires to the CANH and CANL terminals on the board.</li> <li>• Noise on the Can bus. Verify that the shield wire is connected according to the job print.</li> </ul>
SEL DN Pulse Fault	Selector pulsed the DN latch multiple times but the DN state was not latched	<ul style="list-style-type: none"> <li>• Memory of the DN sensor is stored on a state saver latch device. Replace the Selector Board.</li> </ul>
SEL DT Pulse Fault	Selector pulsed the DT latch multiple times but the DT state was not latched	<ul style="list-style-type: none"> <li>• Memory of the DT sensor is stored on a state saver latch device. Replace the Selector Board.</li> </ul>
SEL Norm Lim Clk Flt	Selector pulsed the clock of the UN or DN latch multiple times but the state was not latched	Hardware fault. Replace the Selector Driver board.



Fault	Description	Possible Cause/Suggested Fix
SEL NTSD Comm Fault	Selector recorded a communications fault with the NTS Processor on the Safety CAN bus port.	<ul style="list-style-type: none"> <li>• Faulty CAN bus wiring.</li> <li>• Termination resistors are usually placed at the far end of each BUS. Verify the placement of the Termination resistors.</li> <li>• Try moving the termination resistors to other locations.</li> <li>• Faulty device, replace board.</li> </ul>
SEL Term Lim Clk Flt	Selector pulsed the clock of the UT or DT latch multiple times but the state was not latched	<ul style="list-style-type: none"> <li>• Replace the Selector Driver board.</li> </ul>
SEL UN Pulse Fault	Selector pulsed the UN latch multiple times but the UN state was not latched	<ul style="list-style-type: none"> <li>• Memory of the UN sensor is stored on a state saver latch device. Replace the Selector Board.</li> </ul>
SEL UT Pulse Fault	Selector pulsed the UT latch multiple times but the UT state was not latched	<ul style="list-style-type: none"> <li>• Memory of the UT sensor is stored on a state saver latch device. Replace the Selector Board.</li> </ul>
Selector Count Fault	Selector Count Fault. If the hoistway has been learned and the selector count init flag (tapeless selector) is not set then this error is declared.	<ul style="list-style-type: none"> <li>• The governor encoder has lost battery power.</li> <li>• The encoder was disconnected from the governor.</li> <li>• Faulty encoder connection to the governor</li> <li>• Loss of communications from the Safety Processor Board to the encoder.</li> </ul>

Fault	Description	Possible Cause/Suggested Fix
Selector DZ Off Fault	Selector DZ that is sent to the controller over serial port does not match hardwired DZ on Main I/O Board	<ul style="list-style-type: none"> <li>• From the LCD user interface, navigate to the 'Input and Outputs' menu and then select the 'Car Inputs and Outputs'. View the selector DZSL status and compare it to the DZ/DZ-1 inputs on the main I/O board.</li> <li>• Verify the correct voltage of the DZ input on the main I/O board.</li> <li>• Verify the correct voltage on the selector DZ output.</li> </ul>
Selector Preset Flt	Selector preset position fault	<ul style="list-style-type: none"> <li>• Controller could not establish position from selector pulse count or tapeless encoder. It tried to establish position but pulse count did not match floor tables.</li> <li>• Check pulses on Safety processor board, encoder comm and 485 encoder.</li> </ul>
SFC Relay Failed Off	SFC relay did not pick up as expected.	<ul style="list-style-type: none"> <li>• Faulty SFC output chip. Replace output chip.</li> <li>• Faulty SFC relay on main I/O Board GALX-1102. Replace SFC relay.</li> </ul>
SFC Relay Failed On	SFC relay did not drop as expected when performing a SFC/PFC test.	<ul style="list-style-type: none"> <li>• Faulty SFC output chip. Replace output chip.</li> <li>• Faulty SFC relay on main I/O Board GALX-1102. Replace SFC relay.</li> </ul>
Shutdown Alarm	Shutdown Alarm: The controller is out of service from a fault condition for a time period greater than adjustable shutdown alarm timer.	<ul style="list-style-type: none"> <li>• This error is logged so the system can send notification from the Galileo Monitoring System. Check the previous error that was logged to determine the cause.</li> </ul>
Side Emerg. Exit Flt	Side Emergency Exit Fault	<ul style="list-style-type: none"> <li>• Verify that the side emergency exit is properly shut and the switch is closed.</li> <li>• Faulty wiring in the side emergency exit circuit.</li> </ul>

Fault	Description	Possible Cause/Suggested Fix
Slip Detect Fault	<p>Slip Detection Fault (SPB Velocity difference fault). There is a speed difference between the CPU and the safety processor board possibly because of Rope Slippage. This fault will set the rope gripper or the emergency brake. For jobs with local A17.1 code earlier than 2010 this fault can be disabled by setting the Field Variable Slip Det Dis to =1 (Disabled).  <b>For jobs with 2010 code and later, the gripper or emergency brake will be set regardless of this parameter value.</b></p>	<ul style="list-style-type: none"> <li>• This is a Slip detection mechanism required for 2010 code. The field variable Slip Vel Diff determines how many feet per minute the two speeds are allowed to differ before declaring the fault.</li> <li>• Verify the velocity of the Safety Processor and the main CPU.</li> <li>• Mark the ropes dead level at a particular floor. Run the car away from the floor and then back to the floor. Measure the rope slip. Replace the ropes if necessary.</li> </ul>
SPB Address Error	Safety Processor has an Invalid Address	Program Error
SPB CAN Com Error	Safety Processor Can Communications Error. The Safety Processor is not communicating to the main CPU.	<ul style="list-style-type: none"> <li>• Verify that the MCU LED for the Safety Processor is blinking. If not then call GAL.</li> <li>• Verify that the bus termination jumper is placed on the GALX-1102 board for the Machine Room CAN bus.</li> </ul>
SPB Comm Fault (From NTS)	Selector or NTS Processor recorded a communications fault with the Safety Processor on the Safety CAN bus port.	<ul style="list-style-type: none"> <li>• Faulty CAN bus wiring.</li> <li>• Termination resistors are usually placed at the far end of each BUS. Verify the placement of the Termination resistors.</li> <li>• Try moving the termination resistors to other locations.</li> <li>• Faulty device, replace board.</li> </ul> <p><b>See: NTS SPB Comm Fault</b></p>

Fault	Description	Possible Cause/Suggested Fix
SPB Dev CAN Fault	Safety Processor not communicating to the main CPU.	<ul style="list-style-type: none"> <li>• Faulty Can communication wire connection. Verify proper twisted pair wires to the CANH and CANL terminals on the board.</li> <li>• Noise on the Can bus. Verify that the shield wire is connected according to the job print.</li> </ul>
SPB DL/GS Fault	Safety Processor Door Lock/Gate Switch Fault	<ul style="list-style-type: none"> <li>• Car is moving outside the door zone with the door open. The car will immediately shut down.</li> </ul>
SPB EEprom Fault	Safety Processor EE Prom for device is not working properly	<ul style="list-style-type: none"> <li>• Defective EEprom device or EEprom device is not installed. The car will not be able to run until the EEprom is installed or replaced.</li> </ul>
SPB Enc Opp Dir Flt	Safety Processor encoder opposite direction fault in tapeless encoder jobs. Car moving up while CPU is giving a Down command or vice versa. This fault sets the rope gripper or emergency brake. Disable this fault by setting Field Variable SPB Dir Flt Dis to 1=Disabled.	<ul style="list-style-type: none"> <li>• Speed was greater than 100 foot per minute while the Safety Processor detected velocity in the opposite direction of the controller run command.</li> <li>• Possible Noise on Encoder cable. Check Encoder Voltage.</li> <li>• Check for wire shield connections on GALX-1102 Board.</li> </ul>
SPB ETS Dn Flt Set EB	Safety Processor detected a car speed at the ETS Down terminal limit that was greater than the clamp (parameter) speed. The Safety Processor will drop the Emergency Brake if the Reduced Stroke Buffer option is selected.	<ul style="list-style-type: none"> <li>• Verify that the limit activates at the correct location in the hoistway.</li> <li>• Verify the speed that the car hits the limit and adjust the limit velocity if necessary.</li> <li>• If the acceleration or deceleration rates were changed after the limit velocities were learned, the learn process may need to be repeated or the limit may need to be moved.</li> </ul>

Fault	Description	Possible Cause/Suggested Fix
SPB ETS Down Spd Flt	Safety Processor detected a car speed at the ETS Down terminal limit that was greater than the clamp (parameter) speed	<ul style="list-style-type: none"> <li>• Verify that the limit activates at the correct location in the hoistway.</li> <li>• Verify the speed that the car hits the limit and adjust the limit velocity if necessary.</li> <li>• If the acceleration or deceleration rates were changed after the limit velocities were learned, the learn process may need to be repeated or the limit may need to be moved.</li> </ul>
SPB ETS Up Flt Set EB	Safety Processor detected a car speed at the ETS Up terminal limit that was greater than the clamp (parameter) speed. The Safety Processor will drop the Emergency Brake if the Reduced Stroke Buffer option is selected.	<ul style="list-style-type: none"> <li>• Verify that the limit activates at the correct location in the hoistway.</li> <li>• Verify the speed that the car hits the limit and adjust the limit velocity if necessary.</li> <li>• If the acceleration or deceleration rates were changed after the limit velocities were learned, the learn process may need to be repeated or the limit may need to be moved.</li> </ul>
SPB ETS Up Speed Flt	Safety Processor detected a car speed at the ETS Up terminal limit that was greater than the clamp (parameter) speed	<ul style="list-style-type: none"> <li>• Verify that the limit activates at the correct location in the hoistway.</li> <li>• Verify the speed that the car hits the limit and adjust the limit velocity if necessary.</li> <li>• If the acceleration or deceleration rates were changed after the limit velocities were learned, the learn process may need to be repeated or the limit may need to be moved.</li> </ul>
SPB INS DO Speed Flt	Safety Processor Inspection Door Open Fault	<ul style="list-style-type: none"> <li>• A door is open while running on inspection and the gate and locks are not being bypassed. The car will immediately shut down.</li> </ul>
SPB INS Speed Fault	Safety Processor Inspection Speed Fault	<ul style="list-style-type: none"> <li>• The car exceeded the INS Velocity adjustable variable while running on inspection. The car will immediately shut down.</li> </ul>

Fault	Description	Possible Cause/Suggested Fix
SPB IO Fault	Safety Processor I/O Fault. An input is on in error. The Elevator Status display will show the I/O error.	<ul style="list-style-type: none"> <li>• All inspection inputs and the auto input are off.</li> <li>• More than one inspection or auto input is on at the same time.</li> <li>• A bypass input is on while the car is not on Car top inspection.</li> <li>• Both up and down run output from the main CPU are on at the same time.</li> <li>• The car will not be able to run until the error is cleared.</li> </ul>
SPB LEV Speed Fault	Safety Processor Leveling Speed Fault	<ul style="list-style-type: none"> <li>• Car was traveling at a speed greater than the leveling speed parameter in the door zone with the door open.</li> <li>• Leveling Vel adjustable variable may be set too low.</li> </ul>
SPB Limit Vel Fault	SPB Limit Velocity Fault. During a limit learn, the velocity for one of the limits was recorded at a speed greater than the contract speed of the car. The velocity value of the limit is set to contract speed - 1.	<ul style="list-style-type: none"> <li>• View all the limit velocity values of the safety processor. If a limit velocity value is set to contract speed - 1, then the limit may need to be moved closer to the terminal landing so that the car hits the limit at a slower speed.</li> <li>• Verify the velocity of the safety processor during a normal run. If the velocity value is too high compared to the actual speed of the car, change the RPM parameter for the safety processor until the speed matches the actual car speed. Increase the RPM value to reduce the SPB velocity or reduce the RPM to increase the SPB velocity.</li> </ul>
SPB No Pulses Fault	Safety Processor Pulse Error.	<ul style="list-style-type: none"> <li>• Not enough pulses have occurred during the Pulse Fault Time period. This error is detected only on automatic operation.</li> <li>• Verify that the encoder LED for the Safety Processor on the Main I/O board blinks while the car is running on inspection.</li> <li>• Also verify that the Safety Processor Velocity displayed on the 'Elevator Status' display is correct.</li> </ul> <p>Possible causes are as follows:</p> <ul style="list-style-type: none"> <li>• Improper connection to the motor encoder. Refer to the job specific prints.</li> <li>• Improper connection of encoder jumpers on Main I/O board.</li> </ul>

Fault	Description	Possible Cause/Suggested Fix
SPB NTSD Comm Fault	Safety Processor recorded a communications fault with the NTS Processor on the Safety CAN bus port.	<ul style="list-style-type: none"> <li>• Faulty CAN bus wiring.</li> <li>• Termination resistors are usually placed at the far end of each BUS. Verify the placement of the Termination resistors.</li> <li>• Try moving the termination resistors to other locations.</li> <li>• Faulty device, replace board.</li> </ul>
SPB Par Setup Fault	Safety Processor has a parameter setup fault	<ul style="list-style-type: none"> <li>• Check the Safety Processor parameter settings for Buffer Type and Rear Door. Make sure they are set as required for the job.</li> </ul>
SPB SAF CAN Fault	Safety Processor has a Safety CAN fault	<ul style="list-style-type: none"> <li>• Verify proper twisted pair wires to the SPCH and SPCL terminals on the GALX-1102 board.</li> <li>• Noise on the CAN Bus, verify that the shield wire is connected according to the job print.</li> </ul>
SPB SEL Comm Fault	Safety Processor recorded a communications fault with the Selector on the Safety CAN bus port.	<ul style="list-style-type: none"> <li>• Faulty CAN bus wiring.</li> <li>• Termination resistors are usually placed at the far end of each BUS. Verify the placement of the Termination resistors.</li> <li>• Try moving the termination resistors to other locations.</li> <li>• Faulty device, replace board.</li> </ul>
SPB SFC Off Fault	Safety Processor SFC fault. CPU detected SFC (Secondary Fault Controller) turned off while the ready input (RDY) was still on	<ul style="list-style-type: none"> <li>• Check for faults from the safety processor under MRCAN device fault on the LCD Display Interface.</li> <li>• Replace SFC (EQR) input chip</li> <li>• If no voltage at SFC terminal and no faults in safety processor, replace output chip for SFC on the main i/o board</li> </ul>
SPB Unintend Motion	Safety Processor detected unintended motion of the car.	<ul style="list-style-type: none"> <li>• Safety processor detected unintended motion of elevator with the doors open</li> <li>• Verify that the brake can hold the car at the floor.</li> <li>• Brake not dropping fast enough during an emergency stop. Adjust the brake resistor.</li> </ul>

Fault	Description	Possible Cause/Suggested Fix
SPB Vel Learn Fault	Invalid spb velocity while learning Hoistway or Limits	<ul style="list-style-type: none"> <li>• SPB velocity did not match controller speed while learning hoistway or limits.</li> <li>• Verify the correct velocity on the Safety Processor.</li> </ul>
Speed Control Exit	Speed Control Exited from a fault condition.	<ul style="list-style-type: none"> <li>• The Electrical Safety String was open during a run. Check the safety string inputs.</li> <li>• The Drive dropped the SFD relay causing the RDY input to drop. Check the drive for faults.</li> <li>• The S10 input turned off. Possible short in traveling cable or bad S10 input. Correct short condition or replace S10 input on the GALX-1102 board.</li> <li>• GTS input turned off during run. Rope Gripper turned off.</li> <li>• Inspection Switch applied during run.</li> </ul>
Stalled Fault	Stall Fault occurs if the motion run timer exceeds the stall protection time. The motion run timer is incremented while the car is trying to run.	<ul style="list-style-type: none"> <li>• Increase Stall Timer on the controller under Adjustable Variables and Car Timers. Set the timer to allow the car to run the entire hoistway at the recovery speed.</li> <li>• The recovery speed parameter may need to be increased to 50 fpm or higher. Typically do not set higher than 80 fpm. If the recovery speed parameter has been changed, run the car in between floors on inspection and then return the car to automatic. Verify that the car recovers to a landing without overshooting the floor.</li> </ul>
Stop Switch Fault	Stop switch is pulled while the car is in motion.	<ul style="list-style-type: none"> <li>• Stop switch is pulled.</li> <li>• Faulty wire connection in the stop switch circuit.</li> </ul>
Target Fault at DT	When going down, the target count should always be below the position count. This fault is logged if the target count is above the position count when the DT slowdown limit is hit.	<ul style="list-style-type: none"> <li>• This fault should never occur. Please call the factory if this fault occurs.</li> </ul>



Fault	Description	Possible Cause/Suggested Fix
Target Fault at DT1	This fault is logged if the target count is above the position count when the DT1 slowdown limit is hit	<ul style="list-style-type: none"> <li>• This fault should never occur. Please call the factory if this fault occurs.</li> </ul>
Target Fault at DT2	This fault is logged if the target count is above the position count when the DT2 slowdown limit is hit.	<ul style="list-style-type: none"> <li>• This fault should never occur. Please call the factory if this fault occurs.</li> </ul>
Target Fault at DT3	This fault is logged if the target count is above the position count when the DT3 slowdown limit is hit.	<ul style="list-style-type: none"> <li>• This fault should never occur. Please call the factory if this fault occurs.</li> </ul>
Target Fault at DT4	This fault is logged if the target count is above the position count when the DT4 slowdown limit is hit.	<ul style="list-style-type: none"> <li>• This fault should never occur. Please call the factory if this fault occurs.</li> </ul>
Target Fault at DT5	This fault is logged if the target count is above the position count when the DT5 slowdown limit is hit.	<ul style="list-style-type: none"> <li>• This fault should never occur. Please call the factory if this fault occurs.</li> </ul>
Target Fault at DT6	This fault is logged if the target count is above the position count when the DT6 slowdown limit is hit.	<ul style="list-style-type: none"> <li>• This fault should never occur. Please call the factory if this fault occurs.</li> </ul>

Fault	Description	Possible Cause/Suggested Fix
Target Fault at DTS	This fault is logged if the target count is above the position count when the DTS slowdown limit is hit.	<ul style="list-style-type: none"> <li>• This fault should never occur. Please call the factory if this fault occurs.</li> </ul>
Target Fault at UT	When going up, the target count should always be above the position count. This fault is logged if the target count is below the position count when the UT slowdown limit is hit.	<ul style="list-style-type: none"> <li>• This fault should never occur. Please call the factory if this fault occurs.</li> </ul>
Target Fault at UT1	This fault is logged if the target count is below the position count when the UT1 slowdown limit is hit.	<ul style="list-style-type: none"> <li>• This fault should never occur. Please call the factory if this fault occurs.</li> </ul>
Target Fault at UT2	This fault is logged if the target count is below the position count when the UT2 slowdown limit is hit.	<ul style="list-style-type: none"> <li>• This fault should never occur. Please call the factory if this fault occurs.</li> </ul>
Target Fault at UT3	This fault is logged if the target count is below the position count when the UT3 slowdown limit is hit.	<ul style="list-style-type: none"> <li>• This fault should never occur. Please call the factory if this fault occurs.</li> </ul>
Target Fault at UT4	This fault is logged if the target count is below the position count when the UT4 slowdown limit is hit.	<ul style="list-style-type: none"> <li>• This fault should never occur. Please call the factory if this fault occurs.</li> </ul>

Fault	Description	Possible Cause/Suggested Fix
Target Fault at UT5	This fault is logged if the target count is below the position count when the UT5 slowdown limit is hit.	<ul style="list-style-type: none"> <li>• This fault should never occur. Please call the factory if this fault occurs.</li> </ul>
Target Fault at UT6	This fault is logged if the target count is below the position count when the UT6 slowdown limit is hit.	<ul style="list-style-type: none"> <li>• This fault should never occur. Please call the factory if this fault occurs.</li> </ul>
Target Fault at UTS	This fault is logged if the target count is above the position count when the UTS slowdown limit is hit.	<ul style="list-style-type: none"> <li>• This fault should never occur. Please call the factory if this fault occurs.</li> </ul>
Term Lim Clk Pulse Flt	Selector pulsed the clock of the UT or DT latch multiple times but the state was not latched	<ul style="list-style-type: none"> <li>• Replace the Selector Driver board.</li> </ul> <p><b>See: SEL Term Lim Clk Flt</b></p>
Top Door Lock Fault	The Top Door Lock failed on while the door was open.	<ul style="list-style-type: none"> <li>• Faulty door lock.</li> <li>• Jumper on door lock circuit.</li> <li>• Door lock not adjusted properly.</li> <li>• Faulty wiring to DLT input.</li> <li>• Faulty DLT and DLT-1 inputs (For this to occur both DLT and DLT-1 inputs must fail on).</li> <li>• DOL input failed. Replace DOL input chip.</li> <li>• Door operator open limit DOL is not adjusted properly</li> </ul>
Top Emerg. Exit Flt	Top Emergency Exit Fault	<ul style="list-style-type: none"> <li>• Verify that the top emergency exit is properly shut and the switch is closed.</li> <li>• Faulty wiring in the top emergency exit circuit.</li> <li>• Faulty wiring in the side emergency exit circuit.</li> </ul>

Fault	Description	Possible Cause/Suggested Fix
Top Final Limit Flt	Top Final Limit Open	<ul style="list-style-type: none"> <li>• Car traveled onto the top final limit.</li> <li>• Faulty wiring of the final limit circuit.</li> </ul>
UL and DL Off Fault	Both UL and DL level sensors are off when car is at a floor.	<ul style="list-style-type: none"> <li>• Faulty adjustment of the selector head.</li> <li>• Worn selector guides. Replace selector guides.</li> <li>• Faulty Door Zone Magnet. If this fault occurs at one particular floor, replace the door zone magnet at the floor.</li> <li>• Faulty sensor board. Replace the selector sensor board.</li> </ul>
UL Failed On Fault	UL Failed On Fault. The UL leveling sensor did not go off during a run.	<ul style="list-style-type: none"> <li>• UL hall effect sensor bad on selector sensor board. Replace sensor board.</li> <li>• UL Output Driver failed on. Replace output on selector driver board.</li> <li>• UL inputs failed on. Replace the selector driver board.</li> </ul>
UL,DL & DZ Off at FL	UL, DL & DZ sensors off at floor. The car thinks it should be at a floor or is at a floor and all the floor sensors have turned off.	<ul style="list-style-type: none"> <li>• Loss of power on the selector.</li> <li>• Faulty cable from the selector driver board to the sensor or sensor board.</li> <li>• Faulty wiring from the selector driver board to the main I/O board GALX-1102.</li> </ul>
UL,DL Learn Cnt Flt	Pulses per inch are incorrect from the Encoder RPM/ PPR settings	<ul style="list-style-type: none"> <li>• Dead Zone was estimated to be greater than eight inches</li> <li>• Make sure the car is running at correct speed before learning the hoistway</li> <li>• The recommended distance between UL and DL sensors in tapeless system is 7.5 inches if the controller is configured to stop on pulses</li> </ul>

Fault	Description	Possible Cause/Suggested Fix
UL/DL Dir Seq Fault	<p>UL and DL Direction Fault. Once the car is in Motion, controller verifies the order for the leveling signals. UL, DZ and DL should come in the right sequence depending in the direction of travel. This fault sets the rope gripper or emergency brake. Disable this fault by setting Field Variable ULDL DirFlt Dis to 1=Disabled.</p>	<ul style="list-style-type: none"> <li>• During Setup, the leveling signals may be wired incorrectly. Once in service this fault should not occur. If detected, Check Detailed Fault data to determine direction of travel as well as possible inputs causing error.</li> </ul>
UMotion Auto DO No DZ	<p>Unintended Motion on Automatic with Door Open and Not on a Door Zone. The car was on a door zone with the doors open and then unexpectedly left the door zone while on automatic. This fault sets the gripper or emergency brake.</p>	<ul style="list-style-type: none"> <li>• Verify that the car is not losing a door zone signal at the floor with the doors open.</li> <li>• Verify that the brake drops properly when the car stops. Adjust the brake.</li> <li>• Verify that the main brake can hold a full load. Adjust the brake.</li> </ul>
Umotion Count Fault	<p>Unintended Motion Fault. Unintended motion detected from position count changing by more than 13 inches without the car having a motion commanded.</p>	<ul style="list-style-type: none"> <li>• Verify that the brake can hold the car at the floor.</li> <li>• Brake not dropping fast enough during an emergency stop. Adjust the brake drop resistors.</li> <li>• Verify that the encoder feedback does not continue to move after an emergency stop.</li> </ul>

Fault	Description	Possible Cause/Suggested Fix
UMotion Enc Velocity	Unintended Motion Encoder Velocity. The controller detected an unintended motion fault from the encoder feedback velocity. This fault sets the gripper or emergency brake.	<ul style="list-style-type: none"> <li>• Verify that the brake drops properly when the car stops. Adjust the brake.</li> <li>• Verify that the main brake drops quickly during a high speed stop (opening a door lock). The brake resistor value for a high current brake may need to be adjusted to a lower value.</li> <li>• Verify that the main brake can hold a full load. Adjust the brake.</li> </ul>
UMotion Ins DO No DZ	Unintended Motion on Inspection with Door Open and Not on a Door Zone. The car was on a door zone with the doors open and then unexpectedly left the door zone while on inspection. This fault sets the gripper or emergency brake.	<ul style="list-style-type: none"> <li>• Verify that the car is not losing a door zone signal at the floor with the doors open.</li> <li>• Verify that the brake drops properly when the car stops. Adjust the brake.</li> <li>• Verify that the main brake can hold a full load. Adjust the brake.</li> </ul>
UMotion SPB Velocity	Unintended Motion Safety Processor Velocity. The controller detected an unintended motion fault from the Safety Processor velocity. The Safety processor checks for unintended motion separate from the check on the main CPU. Field variable Griper/EBK Trip set to +1=SPB will cause the main CPU to set the gripper or emergency brake when this fault occurs.	<ul style="list-style-type: none"> <li>• Verify that the brake drops properly when the car stops. Adjust the brake.</li> <li>• Verify that the main brake drops quickly during a high speed stop (opening a door lock). The brake resistor value for a high current brake may need to be adjusted to a lower value.</li> <li>• Verify that the main brake can hold a full load. Adjust the brake.</li> </ul>

Fault	Description	Possible Cause/Suggested Fix
UN Pulse Fault	Selector pulsed the UN latch multiple times but the UN state was not latched	<ul style="list-style-type: none"> <li>• Memory of the UN sensor is stored on a state saver latch device. Replace the Selector Board.</li> </ul> <b>See: Sel UN Pulse Fault</b>
Uncontrolled Leveling	Uncontrolled Leveling Fault. This fault sets the gripper or emergency brake.	<ul style="list-style-type: none"> <li>• Verify that the car relevels properly.</li> <li>• The response, inertia or other gains on the drive may need to be increased.</li> <li>• Check for drive fault during releveling</li> <li>• The brake may not be dropping properly. Readjust the brake.</li> </ul>
Unintended Motion Ft	Safety Processor detected unintended motion of the car.	<ul style="list-style-type: none"> <li>• Verify that the brake can hold the car at the floor.</li> <li>• Brake not dropping fast enough during an emergency stop. Adjust the brake resistor.</li> </ul> <b>See: SPB Unintend Fault</b>
Unintended Motion Ft	Unintended Motion fault	<ul style="list-style-type: none"> <li>• Unintended motion occurred. Car moved out of door zone with doors open or it had a speed feedback when not running from main encoder. If Adjustable Variables-&gt;Car Options-&gt;'Gripper/EBK Trip' is set to +1 then Safety Processor speed could cause fault as well. This is a <b>CPU</b> fault.</li> </ul>
Up Directional Fault	Car unexpectedly hit the Up Normal Limit while running up.	<ul style="list-style-type: none"> <li>• Faulty wiring for the UN limit.</li> <li>• <b>Tape Selector:</b> Incorrect placement of UT magnet (too close to center of tape).</li> <li>• <b>Tapeless Selector:</b> Incorrect placement of UT magnet not aligned properly with magnetic sensor on selector (cross talk from UT magnet to UN sensor).</li> </ul>

Fault	Description	Possible Cause/Suggested Fix
UP I/O Failed Off	The UP input or output has failed off	<ul style="list-style-type: none"> <li>• Fault on Safety Processor. The Safety Processor is located on the MAIN I/O board. This device can disable the run control to the DNR output chip. Check if the SAF-PROC or SAF-PAL FAULT LEDs turn on when the car attempts to run. Check the elevator service, faults, and inputs/outputs on the Safety Processor status of the LCD Display Interface.</li> <li>• Faulty UP output or UPi input. Replace the UP output and UPi input chip.</li> <li>• No 24VDC from the drive. Refer to Schematics.</li> <li>• Incorrect jumper placement on MAIN I/O board. Verify that jumpers on the bottom center of the board are positioned correctly for SOURCE or SINK. The jumpers depend on the drive type and is shown on the drive portion of the job schematic. If necessary move the jumpers to the correct position.</li> <li>• RUN, MC or BRK auxiliary contact not making properly. Verify the operation and contact integrity.</li> </ul>
UP I/O Failed On	The UP input or output has failed on.	<ul style="list-style-type: none"> <li>• Faulty UP output. Replace the UP output chip.</li> <li>• Faulty UPi input. Replace UPi input chip.</li> <li>• Incorrect jumper placement on GALX-1102 board. Verify that jumpers on the bottom center of the board are positioned correctly for SOURCE or SINK. The jumpers depend on the drive type and is shown on the drive portion of the job schematic. If necessary move the jumpers to the correct position.</li> </ul>
Up Normal SW Setup	Up Normal must turn off when the elevator is <b>above</b> the top floor.	<ul style="list-style-type: none"> <li>• Up Normal (UN) switch Turned off before controller detected top landing. The up normal may need to be moved up so it is ON when the elevator is dead level at top floor, and OFF when the elevator is <b>above</b> the top floor . If problem persists, look at hoistway tables to detect possible defective magnets.</li> </ul>



Fault	Description	Possible Cause/Suggested Fix
UPF I/O Failed Off	The UPF input or output has failed off.	<p><b>Hydro</b></p> <ul style="list-style-type: none"> <li>• Fault on Safety Processor Board. The Safety Processor Board can disable the run control to the UPF output chip. Check if the PIC or PAL inhibit LED turns on when the car attempts to run. Check the elevator service, faults, and inputs/outputs on the Safety Processor Board LCD display.</li> <li>• Faulty wiring to the SC common on the MAIN I/O board.</li> <li>• Faulty wiring to the SUF terminal on the MAIN I/O board.</li> <li>• Faulty wiring to the Up Fast valve</li> <li>• Faulty SDFi input (replace input chip).</li> <li>• Faulty SDF output (replace output chip).</li> </ul>
UPF I/O Failed On	The UPF input or output has failed on.	<p><b>Hydro</b></p> <ul style="list-style-type: none"> <li>• Faulty SUFi input (replace input chip).</li> <li>• Faulty SUF output (replace output chip).</li> </ul>
UPS Comm Fault	Power loss: Controller cannot establish comm to UPS	<ul style="list-style-type: none"> <li>• Check wiring and shielded pairs</li> <li>• Defective comm board</li> <li>• Possible bad UPS unit</li> </ul>
UPS Low Bat Capacity	Power loss UPS battery capacity low fault	Battery Capacity went below the threshold set by the parameter 'Low Bat Cap Lev'
UPS Low Bat Voltage	Power loss: UPS battery fault	<ul style="list-style-type: none"> <li>• Defective battery inside UPS unit</li> <li>• Replace UPS</li> </ul>
UPS Low Battery Flt	Power loss: ups battery fault	<ul style="list-style-type: none"> <li>• UPS Battery voltage has dropped below 18V</li> <li>• Replace unit</li> </ul>
UPS On Battery Power	Power loss: UPS on battery power	<ul style="list-style-type: none"> <li>• No Line voltage on UPS. Unit running on battery power</li> </ul>
UPS Turned Off	Power loss: UPS turned off	<ul style="list-style-type: none"> <li>• Power loss on UPS. Power has been turned off</li> </ul>

Fault	Description	Possible Cause/Suggested Fix
User Variable Init	User variable initialization	User related parameters such a password and telephone numbers are being initialized. This error occurs on the first time the GALX-1100 CPU board is being powered up.
UT count Fault	The verification position count for the UT input switch was off by more than 10 inches when the switch was activated.	<ul style="list-style-type: none"> <li>• The car was lost due to a preset error. Check the guides on the selector. Check the fault log for binary preset errors.</li> <li>• The controller has a faulty encoder signal for the pulse count. Check that the car can make long runs without overshooting the floor or stopping short of the floor.</li> <li>• The power common to the limit switches was lost. Check fuse F1 on the selector board.</li> <li>• Incorrect counting of pulse counts. For <b>Tapeless</b>, check encoder connection to motor and encoder wiring. For <b>Tape</b>, check pulse sensors for proper quadrature at selector.</li> <li>• Hoistway not learned properly. Perform a hoistway learn procedure.</li> <li>• UT magnet not adjusted properly. Check at slow speed if sensor input is breaking, making and then breaking again. Magnet needs to be closer to the sensor on the selector.</li> </ul>
UT Failed On Fault	UT input Failed On Fault. The car was at the top floor and the UTS input was low true (UTS switch made) but the UT input was high (UT not made).	<ul style="list-style-type: none"> <li>• The UTS limit is not installed. The UTS limit is used on all controllers as a verification that the car at the top most landing. Add the UTS limit.</li> <li>• The UT did not break at the top terminal landing. Adjust or replace the UT switch.</li> <li>• Faulty UT input. Replace selector board.</li> <li>• Faulty UT sensor on selector sensor board. For <b>Tape</b> replace the sensor board, or For <b>Tapeless</b> replace the individual UT sensor.</li> </ul>

Fault	Description	Possible Cause/Suggested Fix
UT Limit Vel Fault	NTS Processor detected a car speed at the UT terminal limit that was greater than the clamp (parameter) speed	<ul style="list-style-type: none"> <li>• Verify that the limit activates at the correct location in the hoistway.</li> <li>• Verify the speed that the car hits the limit and adjust the limit velocity if necessary.</li> <li>• If the acceleration or deceleration rates were changed after the limit velocities were learned, the learn process may need to be repeated or the limit may need to be moved.</li> </ul> <p><b>See: NTS UT Limit Vel Flt</b></p>
UT Pulse Fault	Selector pulsed the UT latch multiple times but the UT state was not latched	<ul style="list-style-type: none"> <li>• Memory of the UT sensor is stored on a state saver latch device. Replace the Selector Board.</li> </ul> <p><b>See: SEL UT Pulse Fault</b></p>
UT Speed Fault	Car hit the UT Limit at a speed greater than the speed limit setting parameter.	<ul style="list-style-type: none"> <li>• Error previously set from the Safety Processor that is no longer used. (See UT Limit Vel Fault).</li> </ul>
UT1 count Fault	The verification position count for the UT1 input switch was off by more than 10 inches when the switch was activated.	<ul style="list-style-type: none"> <li>• The car was lost due to a preset error. Check the guides on the selector. Check the fault log for binary preset errors.</li> <li>• The controller has a faulty encoder signal for the pulse count. Check that the car can make long runs without overshooting the floor or stopping short of the floor.</li> <li>• The power common to the limit switches was lost. Check fuse F1 on the selector board.</li> <li>• Incorrect counting of pulse counts. For <b>Tapeless</b>, check encoder connection to motor and encoder wiring. For <b>Tape</b>, check pulse sensors for proper quadrature at selector.</li> <li>• Hoistway not learned properly. Perform a hoistway learn procedure.</li> <li>• UT1 magnet not adjusted properly. Check at slow speed if sensor input is breaking, making and then breaking again. Magnet needs to be closer to the sensor on the selector.</li> </ul>

Fault	Description	Possible Cause/Suggested Fix
UT1 Limit Vel Fault	NTS Processor detected a car speed at the UT1 terminal limit that was greater than the clamp (parameter) speed	<ul style="list-style-type: none"> <li>• Verify that the limit activates at the correct location in the hoistway.</li> <li>• Verify the speed that the car hits the limit and adjust the limit velocity if necessary.</li> <li>• If the acceleration or deceleration rates were changed after the limit velocities were learned, the learn process may need to be repeated or the limit may need to be moved.</li> </ul> <p><b>See: NTS UT1 Limit Vel Flt</b></p>
UT2 count Fault	The verification position count for the UT2 input switch was off by more than 14 inches when the switch was activated.	<ul style="list-style-type: none"> <li>• The car was lost due to a preset error. Check the guides on the selector. Check the fault log for binary preset errors.</li> <li>• The controller has a faulty encoder signal for the pulse count. Check that the car can make long runs without overshooting the floor or stopping short of the floor.</li> <li>• The power common to the limit switches was lost. Check fuse F1 on the selector board.</li> <li>• Incorrect counting of pulse counts. For <b>Tapeless</b>, check encoder connection to motor and encoder wiring. For <b>Tape</b>, check pulse sensors for proper quadrature at selector.</li> <li>• Hoistway not learned properly. Perform a hoistway learn procedure.</li> <li>• UT2 magnet not adjusted properly. Check at slow speed if sensor input is breaking, making and then breaking again. Magnet needs to be closer to the sensor on the selector.</li> </ul>
UT2 Limit Vel Fault	NTS Processor detected a car speed at the UT2 terminal limit that was greater than the clamp (parameter) speed	<ul style="list-style-type: none"> <li>• Verify that the limit activates at the correct location in the hoistway.</li> <li>• Verify the speed that the car hits the limit and adjust the limit velocity if necessary.</li> <li>• If the acceleration or deceleration rates were changed after the limit velocities were learned, the learn process may need to be repeated or the limit may need to be moved.</li> </ul> <p><b>See: NTS UT2 Limit Vel Flt</b></p>

Fault	Description	Possible Cause/Suggested Fix
<p>UT3 count Fault</p>	<p>The verification position count for the UT3 input switch was off by more than 18 inches when the switch was activated.</p>	<ul style="list-style-type: none"> <li>• The car was lost due to a preset error. Check the guides on the selector. Check the fault log for binary preset errors.</li> <li>• The controller has a faulty encoder signal for the pulse count. Check that the car can make long runs without overshooting the floor or stopping short of the floor.</li> <li>• The power common to the limit switches was lost. Check fuse F1 on the selector board.</li> <li>• Incorrect counting of pulse counts. For <b>Tapeless</b>, check encoder connection to motor and encoder wiring. For <b>Tape</b>, check pulse sensors for proper quadrature at selector.</li> <li>• Hoistway not learned properly. Perform a hoistway learn procedure.</li> <li>• UT3 magnet not adjusted properly. Check at slow speed if sensor input is breaking, making and then breaking again. Magnet needs to be closer to the sensor on the selector.</li> </ul>
<p>UT3 Limit Vel Fault</p>	<p>NTS Processor detected a car speed at the UT3 terminal limit that was greater than the clamp (parameter) speed</p>	<ul style="list-style-type: none"> <li>• Verify that the limit activates at the correct location in the hoistway.</li> <li>• Verify the speed that the car hits the limit and adjust the limit velocity if necessary.</li> <li>• If the acceleration or deceleration rates were changed after the limit velocities were learned, the learn process may need to be repeated or the limit may need to be moved.</li> </ul> <p><b>See: NTS UT3 Limit Vel Flt</b></p>

Fault	Description	Possible Cause/Suggested Fix
<p>UT4 count Fault</p>	<p>The verification position count for the UT4 input switch was off by more than 24 inches when the switch was activated.</p>	<ul style="list-style-type: none"> <li>• The car was lost due to a preset error. Check the guides on the selector. Check the fault log for binary preset errors.</li> <li>• The controller has a faulty encoder signal for the pulse count. Check that the car can make long runs without overshooting the floor or stopping short of the floor.</li> <li>• The power common to the limit switches was lost. Check fuse F1 on the selector board.</li> <li>• Incorrect counting of pulse counts. For <b>Tapeless</b>, check encoder connection to motor and encoder wiring. For <b>Tape</b>, check pulse sensors for proper quadrature at selector.</li> <li>• Hoistway not learned properly. Perform a hoistway learn procedure.</li> <li>• UT4 magnet not adjusted properly. Check at slow speed if sensor input is breaking, making and then breaking again. Magnet needs to be closer to the sensor on the selector.</li> </ul>
<p>UT4 Limit Vel Fault</p>	<p>NTS Processor detected a car speed at the UT4 terminal limit that was greater than the clamp (parameter) speed</p>	<ul style="list-style-type: none"> <li>• Verify that the limit activates at the correct location in the hoistway.</li> <li>• Verify the speed that the car hits the limit and adjust the limit velocity if necessary.</li> <li>• If the acceleration or deceleration rates were changed after the limit velocities were learned, the learn process may need to be repeated or the limit may need to be moved.</li> </ul> <p><b>See: NTS UT4 Limit Vel Flt</b></p>

Fault	Description	Possible Cause/Suggested Fix
<p>UT5 count Fault</p>	<p>The verification position count for the UT5 input switch was off by more than 32 inches when the switch was activated.</p>	<ul style="list-style-type: none"> <li>• The car was lost due to a preset error. Check the guides on the selector. Check the fault log for binary preset errors.</li> <li>• The controller has a faulty encoder signal for the pulse count. Check that the car can make long runs without overshooting the floor or stopping short of the floor.</li> <li>• The power common to the limit switches was lost. Check fuse F1 on the selector board.</li> <li>• Incorrect counting of pulse counts. For <b>Tapeless</b>, check encoder connection to motor and encoder wiring. For <b>Tape</b>, check pulse sensors for proper quadrature at selector.</li> <li>• Hoistway not learned properly. Perform a hoistway learn procedure.</li> <li>• UT5 magnet not adjusted properly. Check at slow speed if sensor input is breaking, making and then breaking again. Magnet needs to be closer to the sensor on the selector.</li> </ul>
<p>UT5 Limit Vel Fault</p>	<p>NTS Processor detected a car speed at the UT5 terminal limit that was greater than the clamp (parameter) speed</p>	<ul style="list-style-type: none"> <li>• Verify that the limit activates at the correct location in the hoistway.</li> <li>• Verify the speed that the car hits the limit and adjust the limit velocity if necessary.</li> <li>• If the acceleration or deceleration rates were changed after the limit velocities were learned, the learn process may need to be repeated or the limit may need to be moved.</li> </ul> <p><b>See: NTS UT5 Limit Vel Flt</b></p>

Fault	Description	Possible Cause/Suggested Fix
UT6 count Fault	The verification position count for the UT6 input switch was off by more than 42 inches when the switch was activated..	<ul style="list-style-type: none"> <li>• The car was lost due to a preset error. Check the guides on the selector. Check the fault log for binary preset errors.</li> <li>• The controller has a faulty encoder signal for the pulse count. Check that the car can make long runs without overshooting the floor or stopping short of the floor.</li> <li>• The power common to the limit switches was lost. Check fuse F1 on the selector board.</li> <li>• Incorrect counting of pulse counts. For <b>Tapeless</b>, check encoder connection to motor and encoder wiring. For <b>Tape</b>, check pulse sensors for proper quadrature at selector.</li> <li>• Hoistway not learned properly. Perform a hoistway learn procedure.</li> <li>• UT6 magnet not adjusted properly. Check at slow speed if sensor input is breaking, making and then breaking again. Magnet needs to be closer to the sensor on the selector.</li> </ul>
UT6 Limit Vel Fault	NTS Processor detected a car speed at the UT6 terminal limit that was greater than the clamp (parameter) speed	<ul style="list-style-type: none"> <li>• Verify that the limit activates at the correct location in the hoistway.</li> <li>• Verify the speed that the car hits the limit and adjust the limit velocity if necessary.</li> <li>• If the acceleration or deceleration rates were changed after the limit velocities were learned, the learn process may need to be repeated or the limit may need to be moved.</li> </ul> <p><b>See: NTS UT6 Limit Vel Flt</b></p>
UTM Contact/GTS Flt	UTM contact/GTS input pick fault	GTS input did not come on. Gripper is set and GTS did not come on or turned OFF momentarily



Fault	Description	Possible Cause/Suggested Fix
UTS count Fault	Up Terminal Slowdown Limit Count Fault. The verification position count for the UTS input switch was off by more than 10 inches when the switch was activated.	<ul style="list-style-type: none"> <li>• The car was lost due to a preset error. Check the guides on the selector. Check the fault log for binary preset errors.</li> <li>• The controller has a faulty encoder signal for the pulse count. Check that the car can make long runs without overshooting the floor or stopping short of the floor.</li> <li>• The power common to the limit switches was lost. Check fuse F1 on the selector board.</li> <li>• Incorrect counting of pulse counts. For <b>Tapeless</b>, check encoder connection to motor and encoder wiring. For <b>Tape</b>, check pulse sensors for proper quadrature at selector.</li> <li>• Hoistway not learned properly. Perform a hoistway learn procedure.</li> <li>• UTS magnet not adjusted properly. Check at slow speed if sensor input is breaking, making and then breaking again. Magnet needs to be closer to the sensor on the selector.</li> </ul>
UTS Failed On Fault	UTS input Failed On Fault. The car was at the top floor and the UT input was low true (UT switch made) but the UTS input was high (UTS not made).	<ul style="list-style-type: none"> <li>• The UT switch is not wired or UT input was lost. The state of UT is compared to that of UTS.</li> <li>• The UTS limit did not break at the top terminal landing. Adjust the UTS magnet.</li> <li>• Faulty UTS input. Replace the UTS input chip on the GALX-1102 board.</li> <li>• Faulty UTS sensor on selector sensor board. For <b>Tape</b> replace the sensor board, or for <b>Tapeless</b> replace the individual UTS sensor.</li> </ul>
UTS Speed Fault	Car hit the UTS Limit at a speed greater than the speed limit setting parameter	<ul style="list-style-type: none"> <li>• Verify the speed that the car hits the limit. Adjust the velocity limit for that device.</li> </ul>
VEL Decel Fault	Velocity Decel Fault. While the car was in deceleration, the velocity increased.	<ul style="list-style-type: none"> <li>• Most likely cause it that the position feedback had bad data.</li> <li>• APS selector, check for grease or dirt on the tape. Run the car the length of the hoistway while monitoring the LEDs on the camera. If the LEDs flash red, the tape may need to be cleaned or the camera adjusted.</li> <li>• Tapeless selector, make sure the set screw is tight on the governor encoder shaft. Also verify the CAN bus integrity to the Main CPU.</li> </ul>

Fault	Description	Possible Cause/Suggested Fix
Velocity Diff Fault	Velocity difference between demand and encoder feedback. This fault sets the rope gripper or emergency brake. Disable this fault by setting Field Variable Vel Diff Dis to 1=Disabled.	<ul style="list-style-type: none"> <li>• Controller detected a difference between demand and encoder feedback speed greater than the setting under 'Velocity Diff' when the car is decelerating. Make sure speed is tracking properly in acceleration and deceleration. Adjust 'Velocity Diff' based on Speed of the car.</li> </ul>
Wrong Dir Pls Run Dn	Wrong Direction Pulses while car running down. The pulse counts should be counting down while the car is running down.	<ul style="list-style-type: none"> <li>• Check the jumpers on the encoder isolation board. If this car has been previously running properly, the encoder isolation board could be faulty. If during initial setup, change the jumpers for A and A not.</li> </ul>
Wrong Dir Pls Run Up	Wrong Direction Pulses while car running up. The pulse counts should be counting up while the car is running up.	<ul style="list-style-type: none"> <li>• Check the jumpers on the encoder isolation board. If this car has been previously running properly, the encoder isolation board could be faulty. If during initial setup, change the jumpers for A and A not.</li> </ul>
XBK Low DC Bus Volts	Aux Brake board low dc bus voltage fault	<ul style="list-style-type: none"> <li>• Incorrect Setting of Line to Line Brake voltage in Adjustable Variables</li> <li>• Incorrect dip-switch setting for Three Phase or Single Phase</li> <li>• Low Line Voltage</li> <li>• Rectifiers blown or have bad connection</li> </ul>
XBK No Currnt w/Volt	Aux Brake board no current fault with voltage applied	<ul style="list-style-type: none"> <li>• No brake connected</li> <li>• Bad current sensor</li> <li>• Check if board is low current or high current board.</li> </ul>
XBK No DC Bus Volts	Aux Brake board no dc bus voltage fault	<ul style="list-style-type: none"> <li>• No AC Voltage Coming into AC1-AC2-AC3</li> <li>• Rectifiers blown or have bad connection</li> </ul>

Fault	Description	Possible Cause/Suggested Fix
XBK No Output Volts	Aux Brake board not output voltage fault	<ul style="list-style-type: none"> <li>• IGBT Not Gating</li> </ul>
XBK Over Current Flt	Aux Brake board over current fault	<ul style="list-style-type: none"> <li>• IGBT shorted</li> <li>• Free wheeling diode shorted</li> <li>• Gating circuitry shorted ON</li> </ul>
XBK Over Voltage Flt	Aux Brake board over voltage fault	<ul style="list-style-type: none"> <li>• IGBT shorted</li> <li>• Gating circuitry shorted ON</li> </ul>
XBK Rq Volt > DC Bus	Aux Brake board dmd voltage greater than dc bus voltage fault	<ul style="list-style-type: none"> <li>• Incorrect Setting of Pick/Hold/Re-level Voltage in Adjustable Variables</li> <li>• Low Line Voltage</li> </ul>
Zero Vel Decel Roll	Zero Velocity Deceleration Roll. The controller calculated a velocity value of zero during the roll in to constant deceleration.	<ul style="list-style-type: none"> <li>• This fault should never occur. Please call the factory if this fault occurs.</li> </ul>

## 6.2 Detailed Faults Data and Description

---

Example of data stored in the standard or long term fault log:

```

517 Inspection Input Flt  2:10:14  2/19/2015 Position = 1 Occurrences =  1
srv=000, prc=002, drf=000, rdf=000, dpr=000, dir=000, emp=000, med=000
cbl=000, equ=000, fir=000, rfi=000, hsf=000, stf=000, cal=000, esp=000
nst=000, rlv=000, ste=001, dfs=000, st0=000, ins=01h, nds=000, dev=00h
pfl=00h, pf2=00h, dv2=00h, io0=alh, io1=0fh, io2=7eh, io3=20h, io4=c3h
io5=6fh, io6=7ch, io7=8dh, io8=00h, io9=00h, ioA=c7h, ioB=f7h, ioC=ffh
ioD=fbh, ioE=35h, ioF=00h, ioG=00h, ioH=f0h, ioI=0fh, ioJ=f1h, ioK=0fh
ioL=3fh, ioM=30h, ioN=00h, ioO=05h, ioP=07h, ioQ=00h
ioR=00h, ioS=00h, ioT=00h
statusf=00000040h, statusf2=00000000h
DPP Count = 126400, Target = 0, Drv Vel = 0, Enc Vel = 0
Calc Vel = 0, Dmd Vel = 0, Vel Diff = 0, Enc Dir = 0
SPB Poscnt = 0, SPB Vel = 0
SPB Serv = 0h, SPB Cmd = 4h, SPB Stat = 0h
SPB ios1=00h, ios2=00h, ios3=00h, ios4=00h, ios5=00h
Flt Bits 1 = 1h, Flt Bits 2 = 0h, Flt Bits 3 = 1h, Flt Bits 4 = 0h
SS Status=0000h, PWR Status=0000h, Run Status=008013f8h
NTS Vel = 0, NTS Serv = 0h, NTS Cmd = 0h, NTS Stat = 0h
NTS Lim Flt[0] = 0h, NTS Lim Flt[1] = 0h, NTS Lim Flt[2] = 0h
NTS ios1=00h, ios2=00h, ios3=00h
Nudg Flags=00h, Door Req=08h, Call Flags=00h
Chk Run=23h, Chk Start=00h, Chk Level=00h, Chk Door=24h
Front SD=0000h, Rear SD=0000h, Motion Tmr=00001
PAL Vel=00000, PAL Statusf=00h, Inspect Svc=000
Drive Command=0000h, Drive Statusf=0000h
Torque Command=00000, Motor Torque=00000, Percent Load= 4

```

Example of detailed fault data on LCD Display Interface:

```

"srv= 0, prc= 2, drf= 0 "
"rdf= 0, dpr= 0, dir= 0 "

```

```

"emp= 0, med= 0, cbl= 0 "
"equ= 0, fir= 0, rfi= 0 "
"hsf= 0, stf= 0, cal= 0 "
"esp= 0, nst= 0, rlv= 0 "
"ste= 1, dsf= 0, st0= 0 "
"ins=01, nds= 0, dev=00 "
"pfl=00, pf2=00, dv2=00 "
"io0=A1, io1=0F, io2=7E "
"io3=20, io4=C3, io5=6F "
"io6=7C, io7=8D, io8=00 "
"io9=00, ioA=C7, ioB=F7 "
"ioC=FF, ioD=FB, ioE=35 "
"ioF=00, ioG=00, ioH=F0 "
"ioI=0F, ioJ=F1, ioK=0F "
"ioL=3F, ioM=30, ioN=00 "
"ioO=05, ioP=07, ioQ=00 "
"ioR=05, ioS=07, ioT=00 "
"  statusf = 00000040 "
"  statusf2 = 00000000 "
"Dp= 126400, Tg=      0"
"DrvV=    0, EncVel=  0"
"CalcV=    0,DmdVel=  0"
"VDif=    0, Enc Dir = 0 "
"SPB Cnt =      0      "
"SPB Vel=    0, Stat=00 "
"SPB Srv=00,Cmd=04,S1=00 "
"S2=00,S3=00,S4=00,S5=00 "
"FltB1=01      FltB2=00 "
"FltB3=01      FltB4=00 "
"SsStat=0000,PwrStat=0000"
"Run Status = 008013f8 "
"NTS Vel=    0, Stat=00 "

```

```
"NTS Serv=00, Cmd=00      "
"LmF1=00 LmF2=00 LmF3=00 "
"Nio1=00 Nio2=00 Nio3=00 "
"Nud=00, DRq=08, CFg=00  "
"RnS=23, StS=00, LvS=00  "
"DrS=24,FSd=0000,RSd=0000"
"Motion Tmr =      1      "
"PAL Vel=00000, Stat=    "
"Ins Svc=00, % Load =   4"
"DrvCmd=0000,TrqCmd=    0"
"DvStat=0000,MtrTrq=    0"
```

<b>SRV: SRV Service Flag</b>	
0 = Out of Service	15 = Return to Lobby
1 = Automatic	16 = Load Overload
2 = Independent	17 = Massachusetts Medical Emergency
3 = Load Weighing Bypass	18 = Calibrate load weigher
4 = Attendant	19 = CS Elevator Off
5 = Code Blue	20 = HS Elevator Off
6 = Fire Phase 2	21 = Low Pressure Operation
7 = Emergency Power	22 = Hospital Service Operation
8 = Earthquake Emergency	23 = VIP Service Operation
9 = Fire Phase 1 Main Egress	24 = Security Recall
10 = Fire Phase 1 Alternate Egress	25 = Sabbath service
11 = Homing	26 = TUG Service operation
12 = Reset Run Up	27= Hot Oil Operation
13 = Reset Run Down	28= Riot Control
14 = Low Oil Operation	

<b>PRC: Process Flag</b>	
1 = Reset	10 = Motion Mode 7 – Targeting Floor
2 = Inspection	11 = Motion Mode 8 – Emergency Slowdown
3 = Motion:	12 = Safety String
hsf=1, dir=1, Up Fast	13 = Turned Off
hsf=0, dir=1, ul=0, Up Transition	14 = Parked
hsf=0, dir=1, ul=1, Up Leveling	15 = Waiting Assignment
hsf=1, dir=2, Down Fast	16 = Doors Operation
hsf=0, dir=2, dl=0, Down Transition	17 = Elevator Stalled (or Low Oil for Hydro)
hsf=0, dir=2, dl=1, Down Leveling	18 = Elevator Resetting Hydro Jack
4 = Motion Mode 1 – Soft Start	19 = Elevator on Low Oil Pressure mode
5 = Motion Mode 2 – Constant Acceleration	20 = Elevator is in Automatic Learn Hoistway
6 = Motion Mode 3 – Roll Over to Max Velocity	21 = Elevator is in Emergency Power Recovery
7 = Motion Mode 4 – Constant Velocity	22= Hot Oil Mode
8 = Motion Mode 5 – Roll Over to Deceleration	
9 = Motion Mode 6 – Constant Deceleration	

<b>DRF: Front Door Flag</b>	<b>RDF: Rear Door Flag</b>
0 = Door Closed	0 = Door Closed
1 = Door Opening	1 = Door Opening
2 = Door Dwelling	2 = Door Dwelling
3 = Door Closing	3 = Door Closing
4 = Door Nudging Closed	4 = Door Nudging Closed

<b>DPR: Direction Preference Flag</b>	<b>DIR: Car Direction Flag</b>
0 = None	0 = None
1 = Up	1 = Up
2 = Down	2 = Down

<b>EMP: Emergency Power Flag</b>	
0 = Not on Emergency Power 1 = On Emergency Power Waiting 2 = On Emergency Power Waiting with Doors Open 3 = On Emergency Power Returning Home 4 = On Em. Power Returned Home with Doors Open	5 = On Em. Power Returned Home with Doors Closed 6 = On Emergency Power and Selected to Run 7 = On Emergency Power waiting with Doors Closed

<b>MED: Medical Emergency</b>	
0 = No Medical Emergency Service 1 = Recall Car to Medical Emergency Recall Floor 2 = At Return Floor with Door Open (Return Complete)	4 = On EMS Car Call Service 5 = On EMS Car Hold Service (key off but not at the recall floor)



<b>CBL: Code Blue Flag</b>	
0 = No Code Blue	3 = At Code Blue Floor with Door Open
1 = Recall to Emergency Floor	4 = Finished Code Blue
2 = At Code Blue Floor	

<b>EQU: Earthquake Flag</b>	
0 = Not on Earthquake Operation	3 = Recover Away From the Counterweight
1 = Earthquake Sensor Activated	4 = Stopped at a Floor
2 = Counterweight Derailment Sensor Activated	

<b>FIR: Fire Flag</b>	
0 = Not on Fire Service	5 = Phase 2 Constant Pressure Door Open
1 = Phase 1 Main Egress Return	6 = Phase 2 Constant Pressure Door Close
2 = Phase 1 Alternate Egress Return	7 = Phase 2 Door Hold
3 = Phase 1 Completed	8 = Phase 2 Momentary DCB Door Close
4 = Phase 2 Door Hold	

<b>RFI: Rear Fire Flag</b>	
0 = Not on Fire Service	5 = Phase 2 Constant Pressure Rear Door Open
1 = Phase 1 Main Rear Egress Return	6 = Phase 2 Constant Pressure Rear Door Close
2 = Phase 1 Alternate Rear Egress Return	7 = Phase 2 Rear Door Hold
3 = Phase 1 Completed	8 = Phase 2 Momentary DCB Rear Door Close
4 = Phase 2 Rear Door Hold	

<b>HSF: High Speed Flag</b>	<b>STF: Start Flag</b>
0 = No High Speed	0 = Not valid Start
1 = High Speed	1 = Start of Run

<b>CAL: Direction of Calls</b>	
0 = No Call	2 = Below Call
1 = Above Call	3 = Above and Below Calls

<b>ESP: Emergency Stop Flag</b>	<b>NST: Need to Stop Flag</b>
1 = Emergency Stop	1 = Car need to stop at next floor

<b>RLV: Re-level Flag</b>	<b>STE: Step Flag</b>
1 = Car in re-leveling	1 = Step to the next position (non-distance feedback)

<b>DSF (dsf): Door Status Flags</b>	
Bit 0: (preDO) Pre-open Door Flag	Bit 4: (rdsUP) Rear Door Open Sequence Up Pilot
Bit 1: (dsUP) Door Open Sequence Up Pilot	Bit 5: (rdsDP) Rear Door Open Sequence Down Pilot
Bit 2: (dsDP) Door Open Sequence Down Pilot	Bit 6: (rdsNP) Rear Door Open Sequence No Pilot
Bit 3: (dsNP) Door Open Sequence No Pilot	Bit 7:

**ST0: Next Stop Floor - Floor number of next stop**

<b>INS: Inspection Status Flag (Status bit set to “1” when switch is on)</b>	
Bit 0: (INS) Car Top Inspection	Bit 4: (LBP) Lock Bypass
Bit 1: (MRIN) Machine Room Inspection	Bit 5: (GBP) Gate Bypass
Bit 2: (ACC) Access	Bit 6: (AUTI) Not in Automatic (AUTO==0)
Bit 3: (ICI) In Car Inspection	

<b>NDS: Next Car Up Door Sequence</b>	
0 = Initiate Next Up Door Open	3 = Allow door close for onward call
1 = Opening Next Up Door	4 = Allow door close while on next up
2 = Door full open on Next Up	

<b>DEV: Device Number</b>	<b>DV2: Device 2 Number</b>
---------------------------	-----------------------------

<b>PF1: Program Flag 1</b>	<b>PF2: Program Flag 2</b>
----------------------------	----------------------------

<b>STATUSF: Control Status Flag (Status bit set to “1” when status active)</b>	
Bit 0: (sfS10) NO S10 power	Bit 17: (sfTOC) Top of Car Communications Error
Bit 1: (sfHC) NO HC power	Bit 18: (sfDRV) Drive Communications Error
Bit 2: (sfSS) NO SS input	Bit 19: (sfSPB) Safety Processor Board Communications Error
Bit 3: (sfRDY) Drive not ready	Bit 20: (sfDBR) DB Resistor Temp. Error
Bit 4: (sfGRP) Gripper/EBK error	Bit 21: (sfSHD) Shutdown (too many run attempts with faults)
Bit 5: (sfIO) I/O error during redundancy check	Bit 22: (sfAST) Annual Safety Test
Bit 6: (sfINS) Inspection or lock bypass fault	Bit 23: (sfSAF) Waiting for Safe (Door Locks and Gate)
Bit 7: (sfBPI) Binary Position Input Error	Bit 24: (sfTLM) UT,UTS,DT or DTS limit error
Bit 8: (sfPOS) Position Error	Bit 25: (sfGTS) GTS input off
Bit 9: (sfAD) No automatic Doors	Bit 26: (sfDZF) UL, DL and DZ off at floor
Bit 10: (sfSTP) Stop switch open	Bit 27: (sfBKC) Brake Board Can Error
Bit 11: (sfDZ) Door Zone fault	Bit 28: (sfFST) Fire Fighter Stop Switch
Bit 12: (sfGDL) Gate or Door lock fault	Bit 29: (sfSEL) Selector Can error
Bit 13: (sfP) No Potential “P” Input	Bit 30: (sfUDL) UL or DL fault
Bit 14: (sfDCL)No DCL	Bit 31: (sfLEV) Leveling fault
Bit 15: (sfDCC) No Door Close Contact	
Bit 16: (sfBKS) Brake lift switch error	

<b>STATUSF2: Control Status Flag (Status bit set to “1” when status active)</b>	
Bit 0: (sfHWI) Hardware Init fault	Bit 16: (sfECN) Encoder can comm error
Bit 1: (sfFDC) Front Door Closing Fault	Bit 17: (sfIOT) IO Test in progress
Bit 2: (sfRDC) Rear Door Closing Fault	Bit 18: (sfGRT) Gripper Test in progress
Bit 3: (sfLVF) Line Voltage Fault	Bit 19: (sfDVP) No Power to Drive
Bit 4: (sfDVF) Door Voltage Fault	Bit 20: (sfNIT) Non Interference timer
Bit 5: (sfBKR) Brake lift switch run error	Bit 21: (sfDRQ) Door open request
Bit 6: (sfDMO) Door motor overload	Bit 22: (sfDPM) Waiting for DPM
Bit 7: (sfHWL) Learn Hoistway Fault	Bit 23: (sfRPM) Waiting for RPM
Bit 8: (sfHWL) Power Loss UPS Fault	Bit 24: (sfVSC) Viscosity operation
Bit 9: (sfEBK) Emergency Brake Can error	Bit 25: (sfLVR) Leveling request
Bit 10: (sfKEB) KEB Drive Not in Run Mode	Bit 26: (sfTSP) Terminal Limit Speed Clamp
Bit 11: (sfAFS) At Floor Shutdown	Bit 27: (sfSPR) Sped Rate Clamp
Bit 12: (s1036) 1036 board connected	Bit 28: (sfEES) Front EE Test failed fault
Bit 13: (sfRSR) Reset run fault	Bit 29: (sfERS) Rear EE Test failed fault
Bit 14: (sfSCT) Invalid SEL count	Bit 30:
Bit 15: (sfCOP) COP can comm error	Bit 31:

<b>DPP Count (DP): Position counts in pulses</b>	<b>Target (TG) = Target Count in pulses</b>
--	---

Drv Vel (DrvV): Velocity sent to the Drive in fpm (From Dmd Vel and rate limited)	Enc Vel : Velocity feedback from Encoder in fpm
--	---

Calc Vel (CalcV): Speed profile calculated velocity in fpm	Dmd Vel: Demand Velocity ( From Calc Vel and speed clamp limited)
--	---

Vel Diff (VDif): Velocity Difference (Drv Vel – Enc Vel) in fpm	Enc Dir: Encoder Direction 0=none, 1=up, 2=down
---	---

<b>SPB Cnt: Safety Processor Position Count</b>	<b>SPB Vel: Safety Processor Velocity in fpm</b>
---	--

<b>SPB Serv: Safety Processor Board Service:</b>	
0: Automatic	9: Velocity Error
1: Car Top Inspection	10: UP Error on pwrup
2: Gate Bypass operation	11: DNR Error on pwrup
3: Lock Bypass Operation	12: Both UNI and DNI inputs
4: Access	13: EEprom Error
5: Motor Room Inspection	14: No UTS Error
6: In Car Inspection	15: No DTS Error
7: Inspection Error	16: Pulse Error
8: Gate or Lock Bypass Err	17: Unintended Motion Error

<b>SPB Cmd: Safety Processor Command. (Controller command to safety processor)</b>	
Bit 0: 1 = Initialize Position	Bit 8: (brkTG ) 1 = Trigger Brake
Bit 1: 1 = Immediate update	Bit 9: (ebkTG) 1 = Trigger Emergency Brake
Bit 0: (ntsTV ) 1 = NTS Test (verification)	Bit10: (bkLV ) 0 = Brk Line Voltage, 1 = Em Brk Line Voltage
Bit 1: (etsTV ) 1 = ETS Test (verification)	Bit11: (rCAN2) 1 = Reset can2 comm status
Bit 2: (rUMOT ) 1 = Reset Unintended motion fault	Bit12: (ntsT ) 1 = NTS Test
Bit 3: (sUMOT) 1 = Set Unintended motion fault	Bit13: (etsT ) 1 = ETS Test
Bit 4: (gr1T ) 1 = GR1 test	Bit14: (adDIS ) 1 = Automatic Door disabled
Bit 5: (sfcT ) 1 = SFC test	Bit15: (sUMTV ) 1 = Set Unintended motion fault (verification)
Bit 6: (gr1PK ) 1 = GR1 pick command	
Bit 7: (sMENU ) 1 = Force Car Speed Menu	

<b>SPB Stat: Safety Processor Status</b>	
Bit 0: (SFC ) Secondary Fault Control (1=fault)	Bit 4: (VEL) Velocity Fault (1=fault)
Bit 1: (FLT) Pic Fault (SPB CPU 1=fault)	Bit 5: (PCI) Position Count Initialized (1=initialized)
Bit 2: (GRF) Gripper Fault (1=fault)	Bit 6: (ACT) Active Fault (1=fault)
Bit 3: (COM) Comm Fault (1=fault)	Bit 7: (PCU) Position Count Updated (1=updated)

<b>SPB ios1: (S1) Safety Processor I/O Byte 1</b>		<b>SPB ios2: (S2) Safety Processor I/O Byte 2</b>	
Bit 0: DLM	Bit 4: LBP	Bit 0: ICI	Bit 4: RGS
Bit 1: DL	Bit 5: MRI	Bit 1: ACC	Bit 5: RLM
Bit 2: AUTO	Bit 6: UL	Bit 2: UTS	Bit 6: DLB
Bit 3: GBP	Bit 7: INS	Bit 3: DTS	Bit 7: DZO

<b>SPB ios3: (S3) Safety Processor I/O Byte 3</b>		<b>SPB ios4: (S4) Safety Processor I/O Byte 4</b>	
Bit 0: unused	Bit 4: DNR	Bit 0: SFCO	Bit 4: velFLT
Bit 1: unused	Bit 5: GS	Bit 1: PICEN	Bit 5: posINIT
Bit 2: ETS	Bit 6: DLT	Bit 2: LSC	Bit 6: actFLT
Bit 3: UP	Bit 7: unused	Bit 3: comFLT	Bit 7: posUPD

<b>SPB ios5: (S5) Safety Processor I/O Byte 5</b>	
Bit 0: GR1	Bit 4: unused
Bit 1: unused	Bit 5: unused
Bit 2: unused	Bit 6: Up Velocity Direction
Bit 3: unused	Bit 7: Down Velocity Direction

<b>Flt Bits 1 (FltB1): Faults Bits 1 (Byte 0)</b>	
Bit 0: (fHWN) Hoistway Not Learned (1=fault)	Bit 4: (fVELD) Velocity Decel Difference Fault
Bit 1: (fHWI) Hardware Init Fault (1=fault)	Bit 5: (fSPVD) Safety Processor Velocity Difference Fault
Bit 2: (fLIMD) Limit Direction Fault	Bit 6: (fUDLD) UL DL Direction Fault
Bit 3: (fSPBD) Safety Processor Direction Fault	Bit 7: (fLEV) Leveling Fault

<b>Flt Bits 2 (FltB2): Fault Bits 2 (Byte 1)</b>	
Bit 0: (fCOPC) COP CAN COM error	Bit 4: (fSLCT) Selector Count Valid
Bit 1: (fSPBC) Safety Processor CAN COM error	Bit 5: (fSELC) Selector CAN COM error
Bit 2: (fB1B2) unused	Bit 6: (fENCC) CAN Encoder COM error
Bit 3: (fB1B3) unused	Bit 7: (fENCI) CAN Encoder Init



<b>Flt Bits 3 (FltB3): Fault Bits 3 (Byte 2)</b>	
Bit 0: (fDVOF) Drive com off line (1=off line)	Bit 4: (fB2B4) unused
Bit 1: (fDBRT) DBR Temperature Fault	Bit 5: (fB2B5) unused
Bit 2: (fMTOL) Door Motor Overload	Bit 6: (fB2B6) unused
Bit 3: (fB2B3) unused	Bit 7: (fB2B7) unused

<b>Flt Bits 4 (FltB4): Fault Bits 4 (Byte 3)</b>	
Bit 0: (fGRIP) Gripper/EMBK Fault	Bit 4: (fB3B4) unused
Bit 1: (fENCD) Encoder Direction Fault	Bit 5: (fB3B5) unused
Bit 2: (fB3B2) unused	Bit 6: (fB3B6) unused
Bit 3: (fB3B3) unused	Bit 7: (fB3B7) unused

<b>SS Status: Safety String Status</b>	
Bit 0: (ssGOV) Governor input open	Bit 8: (ssFFS) Fire Fighter Stop Switch
Bit 1: (ssTF)Top Final Limit Open	Bit 9: (ssCST) Car Stop Switch
Bit 2: (ssBF) Bottom Final Limit open	Bit 10: (ssMRS) Machine Room Stop Switch
Bit 3: (ssPS) Pit Switch open	Bit 11: (ssGTS) Gripper Trip Switch
Bit 4: (ssHSS) Hoistway Safety	Bit 12:
Bit 5: (ssCTS) Car Top Stop switch open	Bit 13:
Bit 6: (ssCSS) Car Safety Switch open	Bit 14:
Bit 7: (ssRLS) Rail Lock Switch	Bit 15:

<b>PWR Status: Power Status</b>	
Bit 0: (psHC) Hall call power loss	Bit 8:
Bit 1: (psHCL) Hall call light power loss	Bit 9:
Bit 2: (psCC) Car call power loss	Bit 10:
Bit 3: (psCCL) Car call light power loss	Bit 11:
Bit 4: (psLHC) Lobby Hall common power loss	Bit 12:
Bit 5: (psFEP) Fire/Emergency Power Loss	Bit 13:
Bit 6:	Bit 14:
Bit 7:	Bit 15:

<b>Run Status: Control Run Status Flag (Status bit set to “1” when status active)</b>	
Bit 0: (rsRUN) Car is running	Bit 16: (rsEE) Electric eye or Detector Edge
Bit 1: (rsDNR) Down run signal	Bit 17: (rsSE) Safety Edge
Bit 2: (rsUP) Up run signal	Bit 18: (rsEER) Rear Electric eye or Detector edge
Bit 3: (rsDL) Down Door Zone Limit	Bit 19: (rsSER) Rear Safety Edge
Bit 4: (rsUL) Up Door Zone limit	Bit 20: (rsHSF) High Speed Flag
Bit 5: (rsDZ) Door Zone	Bit 21: (rsSTF) Start Flag
Bit 6: (rsDLT) Door Lock Top	Bit 22: (rLSTF) Leveling Start Flag
Bit 7: (rsDLM) Door Lock Middle	Bit 23: (rsDZA) Door Zone OR'd
Bit 8: (rsDLB) Door Lock bottom	Bit 24: (rsDO) Door Open
Bit 9: (rsGS) Gate Switch	Bit 25: (rsDC) Door Close
Bit 10: (rsRLM) Rear Door Lock Middle	Bit 26: (rsDOR) Rear Door Open
Bit 11: (rsRGS) Rear Gate Switch	Bit 27: (rsDCR) Rear Door Close
Bit 12: (rsDOL) Door open limit (0=active)	Bit 28:
Bit 13: (rsDCL) Door Close Limit (0=active)	Bit 29:
Bit 14: (rDOLR) Rear door open limit (0=active)	Bit 30:
Bit 15: (rDCLR) Rear door close limit (0=active)	Bit 31:

**NTS Vel: NTS Processor Velocity**

**NTS Stat: NTS Processor Status**

Bit 0: Direction up,	Bit 4: Velocity direction (should match up or down)
Bit 1: Direction down	Bit 5: Direction fault
Bit 2: SEL comm okay	Bit 6: Limit (EMSD) fault
Bit 3: SPB comm okay	Bit 7: Velocity fault

**NTS Serv: NTS Processor Service**

1 = normal	3 = UN Limit Stop
2 = EM Slowdown	4 = DN Limit Stop

**NTS Cmd: NTS Processor Command**

Bit 0: 1 = (EMSD) Emergency Slowdown	Bit 2: 1 = (ETST) ETS Test
Bit 1: 1 = (NTST) NTS Test	Bit 3: 1 = (ADD) Automatic Door disabled

<b>LimFit0: Limit Fault Byte 0</b>	<b>LimFit1: Limit Fault Byte 1</b>
------------------------------------	------------------------------------

Bit0: unF	Bit4: utsF	Bit0: ut4F	Bit4: dnF
Bit1:	Bit5: ut1F	Bit1: ut5F	Bit5:
Bit2: utF	Bit6: ut2F	Bit2: ut6F	Bit6: dtF
Bit3:	Bit7: ut3F	Bit3:	Bit7:

<b>LimFit2: Limit Fault Byte 2</b>	<b>NTSIO1: NTS Processor I/O Byte 1</b>
------------------------------------	---

Bit0: dtsF	Bit4: dt4F	Bit 0: UN	Bit 4: UT3
Bit1: dt1F	Bit5: dt5F	Bit 1: UT	Bit 5: UT4
Bit2: dt2F	Bit6: dt6F	Bit 2: UT1	Bit 6: UT5
Bit3: dt3F	Bit7:	Bit 3: UT2	Bit 7: UT6

NTSIO2: NTS Processor I/O Byte 2		NTSIO3: NTS Processor I/O Byte 3	
Bit 0: DN	Bit 4: DT3	Bit 0: UPI	Bit 4:
Bit 1: DT	Bit 5: DT4	Bit 1: DNRI	Bit 5:
Bit 2: DT1	Bit 6: DT5	Bit 2: NTSD	Bit 6:
Bit 3: DT2	Bit 7: DT6	Bit 3: NTSD1	Bit 7

Nudg Flags (Nud): Door Nudging Flags	
Bit 0: (ngUP) Nudging Closed with Up Pilot	Bit 4: (rngUP) Rear Nudging Closed with UP
Bit 1: (ngDP) Nudging Closed with Down Pilot	Bit 5: (rngDP) Rear Nudging Closed with Down
Bit 2: (ngNP) Nudging Closed with No Pilot	Bit 6: (rngNP) Rear Nudging Closed with No Pilot
Bit 3:	Bit 7:

Door Req (DRq): Door Request Flags	
Bit 0: (doRQ) Front Door Open Request	Bit 4: (rdoRQ) Rear Door Open Request
Bit 1: (dbRQ) Front Door Open Button Request	Bit 5: (rdbRQ) Rear Door Open Button Request
Bit 2: (cdRQ) Front Car Call Door Open Request	Bit 6: (rcdRQ) Rear Car Call Door Open Request
Bit 3: (doEN) Front Door Open Enable	Bit 7: (rdoEN) Rear Door Open Enable

<b>Call Flags (CFg): Onward Call Flags</b>	
Bit 0: (dcAB) Directional Call Above	Bit 4: (occAB) Onward Car Call Above
Bit 1: (dcBL) Directional Call Below	Bit 5: (occBL) Onward Car Call Below
Bit 2: (owcAB) Onward Call Above	Bit 6: (ohcAB) Onward Hall Call Above
Bit 3: (owcBL) Onward Call Below	Bit 7: (ohcBL) Onward Hall Call Below

**Chk Run (RnS) : Check Run Status – Software location of last execution of the check run status routine.**

**Chk Start (StS) : Check Start Status – Software location of the last execution of the check start routine.**

**Chk Level (LvS): Check Leveling Status – Software location of the last execution of the check leveling routine.**

**Chk Door (DrS): Check Door Status – Software location of the last execution of the check door routine.**

<b>Front SD (FSd): Front Slowdown Flags</b>	
Bit 0: (UC) Up Hall Call Slowdown	Bit 8: (IU) IR Up Hall Call Slowdown
Bit 1: (DC) Down Hall Call Slowdown	Bit 9: (ID) IR Down Hall Call Slowdown
Bit 2: (CC) Car Call Slowdown	Bit 10:
Bit 3:	Bit 11:
Bit 4: (UD) Up Call Door Open Request	Bit 12:
Bit 5: (DD) Down Call Door Open Request	Bit 13:
Bit 6: (CD) Car Call Door Open Request	Bit 14:
Bit 7:	Bit 15:

<b>Rear SD (RSd): Rear Slowdown Flags</b>	
Bit 0: (UC) Up Hall Call Slowdown	Bit 8: (IU) IR Up Hall Call Slowdown
Bit 1: (DC) Down Hall Call Slowdown	Bit 9: (ID) IR Down Hall Call Slowdown
Bit 2: (CC) Car Call Slowdown	Bit 10:
Bit 3:	Bit 11:
Bit 4: (UD) Up Call Door Open Request	Bit 12:
Bit 5: (DD) Down Call Door Open Request	Bit 13:
Bit 6: (CD) Car Call Door Open Request	Bit 14:
Bit 7:	Bit 15:

**Motion Tmr: Motion Timer – Timer while the car is in or attempting motion. 100 msec**

**PAL Vel: Safety PAL Velocity in fpm**

<b>PAL Stat: Safety PAL Status</b>	
Bit 0: (PFT) Pulse Fault,	Bit 4: (RSB) Reduced Stroke Buffer Enabled
Bit 1: (UTF) ETSU Fault	Bit 5: (TST) ESLD Test (Ignore ESLD and/or Write Parameter Enable)
Bit 2: (DTF) ETSD Fault	Bit 6: (REN) Rear Door Enable
Bit 3: (FLT) PAL Fault	Bit 7: Encoder Direction (0=normal, 1=invert)

<b>Inspect Svc: Inspection Service</b>	
0 = Invalid Inspection Input	5 = Car Top Inspection Lock Bypass
1 = Car Top Inspection	6 = Car Top Inspection Gate Bypass
2 = Machine Room Inspection	7 = Car Top Inspection Gate and Lock Bypass
3 = Access Inspection	
4 = In-Car Inspection	

**% Load:Percent Load Calculated load value from the load weigher**

<b>DrvCmd: Drive Command</b>	
Bit 0: (CRL) 1=Control Release	Bit 8:
Bit 1: (FLT) 1=Error Occurred	Bit 9:
Bit 2: (RUN) 0=stop, 1=run	Bit 10:
Bit 3: (REV) 0=forward, 1=reverse	Bit 11:
Bit 4:	Bit 12:
Bit 5:	Bit 13:
Bit 7:	Bit 14:
	Bit 15:

TrqCmd: Torque Command – Calculated Torque value sent to the drive

MtrTrq: Motro Torque – Actual torque value from the drive

6.2.1 Detailed Fault I/O Data Example

The data in the I/O block is read from left to right with the left-most bit being the MSB (Most Significant Bit) and the right-most bit being the LSB (Least Significant Bit). Each bit represents the state (on or off) of the corresponding I/O. The table below provides the HEX number and the associated Binary number.

CONVERSION TABLE

HEX	BINARY	DECIMAL
0	0 0 0 0	0
1	0 0 0 1	1
2	0 0 1 0	2
3	0 0 1 1	3
4	0 1 0 0	4
5	0 1 0 1	5
6	0 1 1 0	6
7	0 1 1 1	7
8	1 0 0 0	8
9	1 0 0 1	9
A	1 0 1 0	10
B	1 0 1 1	11
C	1 1 0 0	12
D	1 1 0 1	13
E	1 1 1 0	14
F	1 1 1 1	15



The **example** below shows how to interpret the detailed fault data for the I/O blocks. Given that IO0 is a value of “D1” hex. Place the “D” in the first hex value block and then the “1” in the second hex value block. Follow the red arrows below. Go to the next diagram to convert the inputs to binary.

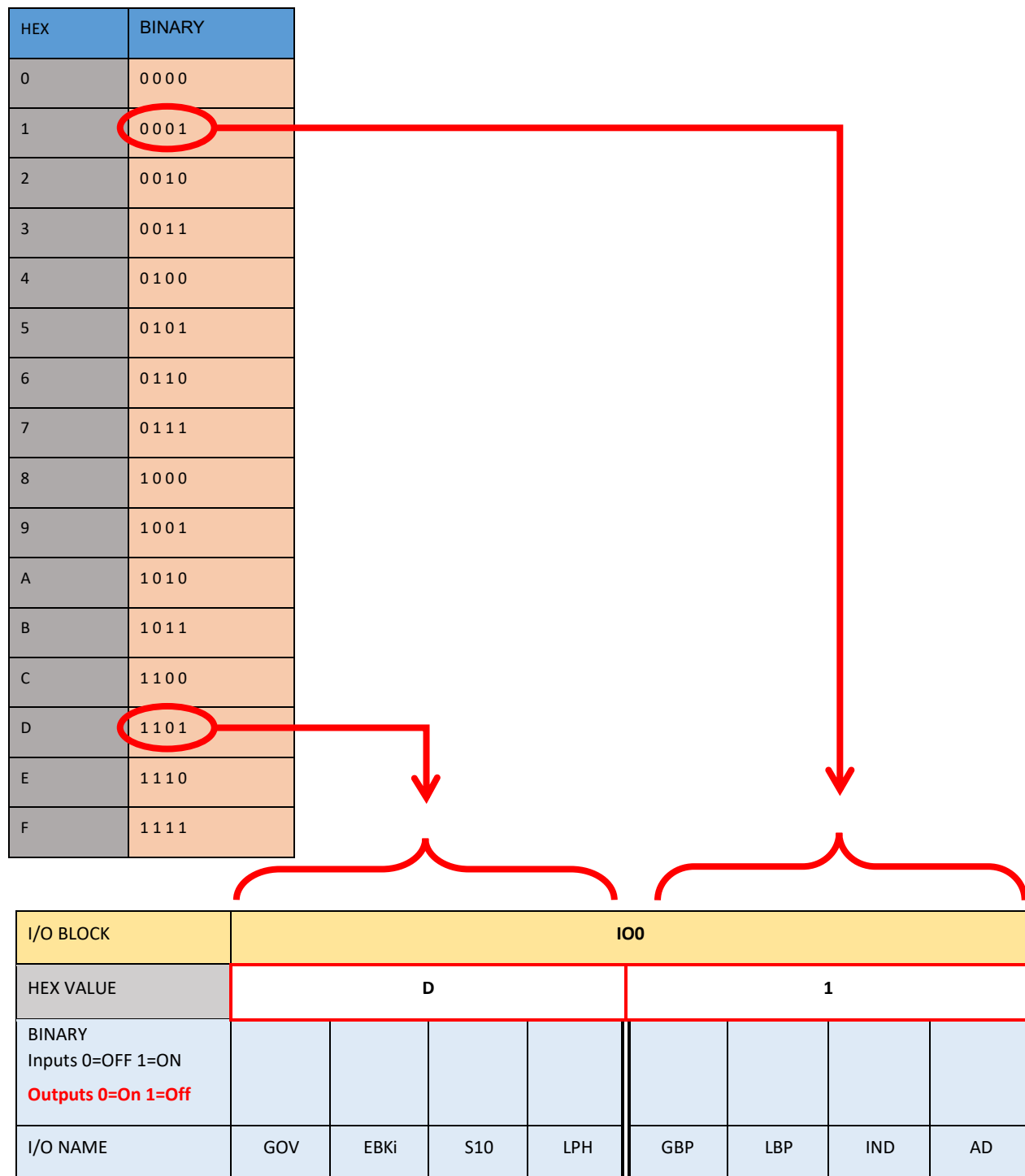

Place the Binary value for D (1101) in the first four bit locations and then place the binary value for 1 (0001) in the last four bit locations. The 1's show which inputs are on.

HEX	BINARY
0	0000
1	0001
2	0010
3	0011
4	0100
5	0101
6	0110
7	0111
8	1000
9	1001
A	1010
B	1011
C	1100
D	1101
E	1110
F	1111

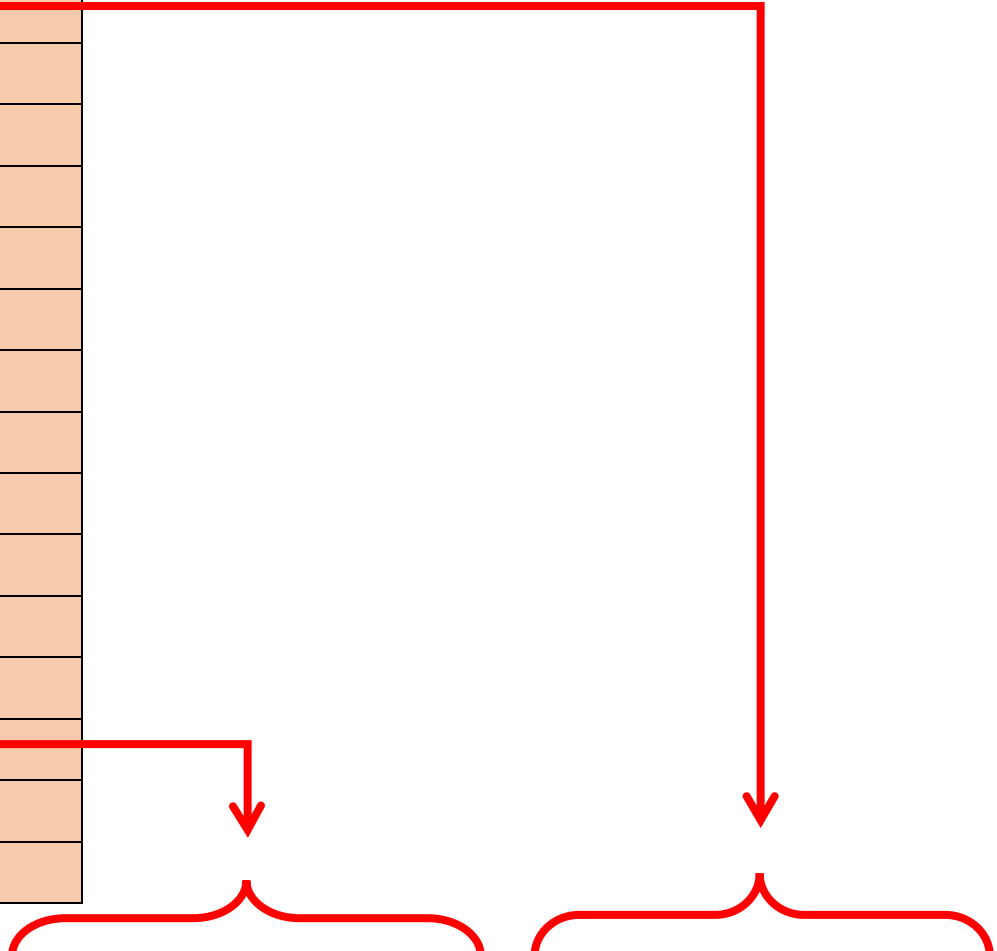

I/O BLOCK	I00							
HEX VALUE	D				1			
BINARY Inputs 0=OFF 1=ON <b>Outputs 0=On 1=Off</b>	1	1	0	1	0	0	0	1
I/O NAME	GOV	EBKi	S10	LPH	GBP	LBP	IND	AD

6.2.2 Detailed Fault I/O Data Form

I/O Blocks:

I/O BLOCK	IO0							
HEX VALUE								
BINARY Inputs 0=OFF 1=ON <b>Outputs 0=On 1=Off</b>	<b>MSB</b>							<b>LSB</b>
I/O NAME	GOV	EBKi	S10	LPH	GBP	LBP	IND	AD

I/O BLOCK	IO1							
HEX VALUE								
BINARY Inputs 0=OFF 1=ON <b>Outputs 0=On 1=Off</b>	<b>MSB</b>							<b>LSB</b>
I/O NAME	TAD	BAU	BAD	ACC	HSS	PS	BF	TF

I/O BLOCK	IO2							
HEX VALUE								
BINARY Inputs 0=OFF 1=ON <b>Outputs 0=On 1=Off</b>	<b>MSB</b>							<b>LSB</b>
I/O NAME	RLM	DLT-1	DLT	DLM-1	DLM	DLB-1	DLB	TAU

I/O BLOCK	IO3							
HEX VALUE								
BINARY Inputs 0=OFF 1=ON <b>Outputs 0=On 1=Off</b>	<b>MSB</b>							<b>LSB</b>
I/O NAME	EBK1i	EBKS	BKS	MDCR	BDC	MDC	TDC	RLM-1

I/O BLOCK	IO4							
HEX VALUE								
BINARY Inputs 0=OFF 1=ON <b>Outputs 0=On 1=Off</b>	<b>MSB</b>							<b>LSB</b>
I/O NAME	MRSW	AUTO	MRI	MRIU	MRIE	MRID	PFCi	SFCi

I/O BLOCK	IO5							
HEX VALUE								
BINARY Inputs 0=OFF 1=ON <b>Outputs 0=On 1=Off</b>	<b>MSB</b>							<b>LSB</b>
I/O NAME	FST	GS-1	GS	RGS-1	<b>GRT2</b>	<b>GRT1</b>	GTS	RDY

I/O BLOCK	IO6							
HEX VALUE								
BINARY Inputs 0=OFF 1=ON <b>Outputs 0=On 1=Off</b>	<b>MSB</b>							<b>LSB</b>
I/O NAME	RGS	DZ-1	DZ	UN	UTS	DN	DTS	CTA

I/O BLOCK	IO7							
HEX VALUE								
BINARY Inputs 0=OFF 1=ON <b>Outputs 0=On 1=Off</b>	<b>MSB</b>							<b>LSB</b>
I/O NAME	INS	IU	IEN	ID	FFS	CS	ICI	P

I/O BLOCK	IO8							
HEX VALUE								
BINARY BINARY Inputs 0=OFF 1=ON <b>Outputs 0=On 1=Off</b>	<b>MSB</b>							<b>LSB</b>
I/O NAME	RUNX	RUNAi	MCX	RUNi	BRKi	DON	MCAi	MCCi

I/O BLOCK	IO9							
HEX VALUE								
BINARY Inputs 0=OFF 1=ON <b>Outputs 0=On 1=Off</b>	<b>MSB</b>							<b>LSB</b>
I/O NAME					ETS	UPI	NTSDi	DNI

I/O BLOCK	IOA							
HEX VALUE								
BINARY Inputs 0=OFF 1=ON <b>Outputs 0=On 1=Off</b>	<b>MSB</b>							<b>LSB</b>
I/O NAME	<b>FSTP1</b>	<b>FSTP</b>	<b>LE1</b>	<b>LE</b>	GR2R	<b>FLH</b>		

I/O BLOCK	IOB							
HEX VALUE								
BINARY Inputs 0=OFF 1=ON <b>Outputs 0=On 1=Off</b>	MSB							LSB
I/O NAME	<b>EBK1</b>	BUZ	FF	DBG	<b>PFCO</b>	<b>MCA</b>	<b>MCC</b>	RST

I/O BLOCK	IOC							
HEX VALUE								
BINARY Inputs 0=OFF 1=ON <b>Outputs 0=On 1=Off</b>	MSB							LSB
I/O NAME	UPF	<b>UP</b>	DF	<b>DNR</b>	<b>RUN</b>	<b>RUNA</b>		

I/O BLOCK	IOD							
HEX VALUE								
BINARY Inputs 0=OFF 1=ON <b>Outputs 0=On 1=Off</b>	MSB							LSB
I/O NAME						<b>DBC</b>	<b>EBK</b>	<b>BRK</b>

I/O BLOCK	IOE							
HEX VALUE								
BINARY Inputs 0=OFF 1=ON <b>Outputs 0=On 1=Off</b>	MSB							LSB
I/O NAME	HWS	MRS	ALT	MES	FSX	BP	FS	FEP

I/O BLOCK	IOF							
HEX VALUE								
BINARY Inputs 0=OFF 1=ON <b>Outputs 0=On 1=Off</b>	MSB							LSB
I/O NAME					EMP	EPT	EPS	HWS2

I/O BLOCK	IOG							
HEX VALUE								
BINARY Inputs 0=OFF 1=ON <b>Outputs 0=On 1=Off</b>	MSB							LSB
I/O NAME					DET	CTS	CSS	RLS

I/O BLOCK	IOH							
HEX VALUE								
BINARY Inputs 0=OFF 1=ON <b>Outputs 0=On 1=Off</b>	MSB							LSB
I/O NAME	LIG	FAN	CDL	CUL	IFB	IFL		

I/O BLOCK	IOI							
HEX VALUE								
BINARY Inputs 0=OFF 1=ON <b>Outputs 0=On 1=Off</b>	<b>MSB</b>							<b>LSB</b>
I/O NAME (Tape)	DZD-1	DZU-1	DZD	DZU	DL	DZA	DZ-2	UL
I/O NAME (Tapeless)			DZD	DZU	DL	DZA	DZ-2	UL

I/O BLOCK	IOJ							
HEX VALUE								
BINARY Inputs 0=OFF 1=ON <b>Outputs 0=On 1=Off</b>	<b>MSB</b>							<b>LSB</b>
I/O NAME	DL4	DL3	DL2	DL1	UL4	UL3	UL2	UL1

I/O BLOCK	IOK							
HEX VALUE								
BINARY Inputs 0=OFF 1=ON <b>Outputs 0=On 1=Off</b>	<b>MSB</b>							<b>LSB</b>
I/O NAME (Tape)			BP32	BP16	BP8	BP4	BP2	BP1
I/O NAME (Tapeless)								



I/O BLOCK	IOL							
HEX VALUE								
BINARY Inputs 0=OFF 1=ON <b>Outputs 0=On 1=Off</b>	<b>MSB</b>							<b>LSB</b>
I/O NAME (Tape)	UT3	UT2	UT1	UTS-1	UTsn	UT	UNsn	UN-1
I/O NAME (Tapeless)	UT3	UT2	UT1	UTS-1		UT		UN-1

I/O BLOCK	IOM							
HEX VALUE								
BINARY Inputs 0=OFF 1=ON <b>Outputs 0=On 1=Off</b>	<b>MSB</b>							<b>LSB</b>
I/O NAME (Tape)	DTsn	DT	DNsn	DN-1		UT6	UT5	UT4
I/O NAME (Tapeless)		DT		DN-1		UT6	UT5	UT4

I/O BLOCK	ION							
HEX VALUE								
BINARY Inputs 0=OFF 1=ON <b>Outputs 0=On 1=Off</b>	<b>MSB</b>							<b>LSB</b>
I/O NAME		DT6	DT5	DT4	DT3	DT2	DT1	DTS-1

I/O BLOCK	IOO							
HEX VALUE								
BINARY Inputs 0=OFF 1=ON <b>Outputs 0=On 1=Off</b>	<b>MSB</b>							<b>LSB</b>
I/O NAME				SE	DCL	DOL	EE	DPM

I/O BLOCK	IOP							
HEX VALUE								
BINARY Inputs 0=OFF 1=ON <b>Outputs 0=On 1=Off</b>	MSB							LSB
I/O NAME		RVD	REV	DO	HVD	DC	NUD	

I/O BLOCK	IOQ							
HEX VALUE								
BINARY Inputs 0=OFF 1=ON <b>Outputs 0=On 1=Off</b>	MSB							LSB
I/O NAME		ALM*	HBE*	DOB	DCB	FS2C	FS2H	FS2OF

I/O BLOCK	IOR							
HEX VALUE								
BINARY Inputs 0=OFF 1=ON <b>Outputs 0=On 1=Off</b>	MSB							LSB
I/O NAME	8C	7C	6C	5C	4C	3C	2C	1C

I/O BLOCK	IOS							
HEX VALUE								
BINARY Inputs 0=OFF 1=ON <b>Outputs 0=On 1=Off</b>	MSB							LSB
I/O NAME				SER	DCLR	DOLR	EER	RPM

I/O BLOCK	IOT							
HEX VALUE								
BINARY Inputs 0=OFF 1=ON <b>Outputs 0=On 1=Off</b>	MSB							LSB
I/O NAME		RVDR	REVR	DOR	HVDR	DCR	NUDR	



**NOTE**

I/O location depends on specific job. On earlier software versions, some of the selector I/O name will not match the table above. The software version 7.1.26 and above is setup to work with either name. To make the names match, the io.dat file must be edited as follows:

**Tape Selector**

**From:**

```
141, UL, DZsn, DZA, DL, DZ1A, DZ2A, DZ1B, DZ2B,
144, UNL, UNsn, UT, UTsn,UTSsn, , , ,
145, , , , , DNL, DNSn, DT, DTsn,
146, DTSsn, , , , , , , ,
```

**To:**

```
141, UL, DZ-2, DZA, DL, DZU, DZD,DZU-1,DZD-1,
144, UN-1, UNsn, UT, UTsn,UTS-1, , , ,
145, , , , , DN-1, DNSn, DT, DTsn,
146,DTS-1, , , , , , , ,
```

**Tapeless Selector**

**From:**

141, UL, DZsn, DZA, DL, DZU, DZD, , ,  
144, , UNsn, UT, , UTSSn, , , ,  
145, , , , , , DNSn, DT, ,  
146, DTSSn, , , , , , , ,

**To:**

141, UL, **DZ-2**, DZA, DL, DZU, DZD, , ,  
144, **UN-1**, , UT, , **UTS-1**, , , ,  
145, , , , , **DN-1**, , DT, ,  
146, **DTS-1**, , , , , , , ,

## Section 7 – Adjustable Variables

### 7.1 Main CPU Adjustable Variables

#### 7.1.1 Car Motion Submenu

Field Variable	Min	Max	Initial	Units	Description
<b>Table 7-1: Car Motion</b>					
Acceleration	50	300	92	fpm/s	<b>Acceleration Rate.</b> The constant acceleration rate to reach top speed.
Access DT Dist	0	120	24	inches	<b>Access DT Distance.</b> Distance from DT limit for the bottom access limit to be software activated. The controller counts pulses from the DT limit.
Access Speed	0	75	35	fpm	<b>Access Speed.</b> Car velocity while running on access .
Access UT Dist	0	120	24	inches	<b>Access UT Distance.</b> Distance from UT limit for the top access limit to be software activated. The controller counts pulses from the UT limit.
Adv Pre-Torque	0	1	0	-	<b>Advance Pretorque.</b> When set, the controller will pick the motor contactor and pretorque the motor when the door closes to the DLM limit. It is enabled to improve floor to floor times when pretorque is used. 0 = Off 1 = On
APS Dead Zone	0.1	0.5	0.25	inches	<b>APS Selector Dead Zone.</b> This is the distance that the car can move without calling for a releve.
Balanced Load	0	100	40	%	<b>Balanced Load.</b> Percent load of the counterweight.
Decel Jerk	50	480	125	fpm/s/s	<b>Deceleration Jerk Rate.</b> Maximum jerk rate to roll from top speed to constant deceleration.
Decel Rate	50	300	92	fpm/s	<b>Deceleration Rate.</b> The constant deceleration rate from top speed to leveling speed when stopping for a floor.

Field Variable	Min	Max	Initial	Units	Description
<b>Table 7-1: Car Motion</b>					
Dist Feed Fwd	0	1.3	0	-	<b>Distance Feed Forward.</b> During the final approach to the floor, when using a tape selector, the number of pulses to calculate the velocity is 64 pulses per foot. So during this time, if the CPU does not see a distance change, it calculates the distance the car should move over the next ten millisecond period and then uses that value to calculate next velocity value. This value is a multiplier for what percentage of the velocity calculation to uses. When the next pulse comes in, the CPU calculates the velocity value as normal.
DL DeadZone Sel	0	15	3	-	<b>DL Dead Zone Sensor.</b> Adjusts the width of the door zone from four DL sensors. DL 1 is the outer most sensors whereas DL 4 is the inner most sensor. Each of the four bits, 0-3, of this parameter represents which DL sensor is being used. Bit 0 for sensor DL1 ... Bit 3 for sensor DL4. So a value of 3 will use sensor DL1 and DL2. (Used on tape applications). A value of 0 defaults to using DL1.
DON Start Ctrl	0	1	1	-	<b>DON Start Ctrl.</b> Drive ON Start Control. When set to 1 the controller starts the pattern delay after the drive on signal (DON) from the drive.
Drv Speed Mult	0.3	2	1	-	<b>Drive Speed Multiplier.</b> Used for KEB Drive, to adjust the speed of the elevator.
EM Decel Lev	50	300	100	fpm/s	<b>Emergency Deceleration Rate to Leveling Rate.</b>
Em Decel Rate	80	360	180	fpm/s	<b>Emergency Deceleration Rate.</b> The rate at which the elevator will decelerate when it is doing an emergency slowdown.
Encoder Dir	0	1	0	-	<b>Encoder Direction for CAN Bus Encoder.</b> Set to zero or one during Setup to get correct direction of pulses for the CAN encoder.
Encoder PPR	60	32000	2048	PPR	<b>Encoder Pulses Per Revolution.</b> The number of pulses the motor encoder produces per revolution.

Field Variable	Min	Max	Initial	Units	Description
<b>Table 7-1: Car Motion</b>					
Encoder RPM	1	3000	105	RPM	<b>Encoder Revolutions Per Minute.</b> The number of revolutions per minute the motor makes at top speed.
Field Weaken	60	110	110	% vel	<b>Field Weakening Velocity.</b> Percent of velocity above which the motor field is weakened to allow the car to reach top speed.
Floor Targ Dis	1.2	25	12	inches	<b>Floor Target Distance.</b> Distance to start leveling mode into the floor. Increasing this distance will lower the jerk rate.
HS Recovery Spd	25	Top Speed	150	fpm	High Speed Recovery Speed. When using an APS selector, the car can recover from in between floors at the HS Recover Speed using a normal run profile. This value can be set to top speed. If the car is within 30 inches of a floor, it will recover to the floor at the Recovery Speed value using the recovery profile.
Ins Decel Stop	50	480	300	fpm/s	<b>Inspection Deceleration Stop Rate.</b> The rate for the elevator to decelerate from inspection speed to zero.
Inspect Speed	0	150	40	fpm	<b>Inspection Speed.</b> Maximum car speed while running on inspection.
Leveling Speed	1	15	5	fpm	<b>Leveling Speed.</b> Maximum car speed while leveling into the floor.
MC Drop Dly Tim	1	3	1	sec	<b>MC Contactor Drop Delay Timer.</b> MC and Run contactors drop delay <i>after</i> the Up or Down direction ( <b>Car Motion -&gt; Soft Stop Time</b> ) are removed.
Motor RPM	0	3000	500	RPM	<b>Motor RPM</b> (used for KEB drive)
Overspeed Trip	80	125	110	%	<b>Over Speed Trip.</b> Percentage of contract speed the controller will drop the rope gripper.
Pattern Delay	0	3	0	sec	<b>Pattern Delay.</b> Delay time before the speed profile will start.

Field Variable	Min	Max	Initial	Units	Description
<b>Table 7-1: Car Motion</b>					
Pls Cnt Upd Err	0	2	1	inches	<b>Position Count Update Error.</b> If the count is off by more than this value and the update flag is enabled, the position pulse count is updated. If this value is set to zero and the update flag is enabled, then the pulse count is updated every time the DZ is hit at high speed.
Pls Err Delay	1	10000	5000	1/sec	<b>Position Count Update Error Delay.</b> This number is the time delay from when DZ is hit until the input is read. The time delay parameter, times the current speed of the car, is used to estimate the number of pulses the count will change during the turn on time of the DZ input.
Pos Count Upd	0	7	0	-	<b>Position Count Update Flag.</b> The pulse count is checked every time the DZ input is hit. +1 = Update the DPP floor count as the elevator passes by a landing and hits DZ. +2 = Interrupt the CPU when DZ hit otherwise the update is done during the loop time (roughly 1 msec). +4 = Update every time the DZ is hit and the car is at constant speed regardless of the pulse count update error value.
Preopen Delay	0	3200	0.5	sec	<b>Preopen Delay.</b> Delay time to preopen the door starting from when the car reaches 3 inches from dead level and the door can safely be opened.
Recovery Speed	15	100	25	fpm	<b>Recovery Speed</b> to the nearest floor.
Relev Pat Dly	0	3	0	sec	<b>Relevel Pattern Delay.</b> Delay time before speed profile will start on a relevel.
Relev St Time	0	2	0	sec	<b>Relevel Start Velocity Hold Time.</b> If relevel start speed is set to a non zero value, controller will use that value for the speed before going into relevel velocity This parameter controls how long we stay in Relevel Start Velocity



Field Variable	Min	Max	Initial	Units	Description
<b>Table 7-1: Car Motion</b>					
Relev Strt Spd	0	15	0	fpm	<b>Relevel Start Speed.</b> Maximum starting velocity for a relevel. Car will stay in relevel Start speed for a time set by parameter ' <b>Relev St Time</b> ' and then switch to relevel Speed.
Relevel Speed	1	15	6	fpm	<b>Relevel Speed.</b> Maximum car speed during releveling operation.
Roll Over Jerk	50	480	125	fpm/s/s	<b>Rollover Jerk Rate.</b> Maximum roll jerk rate while rolling into top speed.
Rope Comp Torq	0	50	0	offset	<b>Rope Compensation Torque.</b> Used primarily on gearless machines that do not have any compensating chains. This parameter adds torque to the pretorque value to compensate for weight of the elevator cables holding the car. The value is calculated from the position of the car in the hoistway.
Soft Start Jerk	50	480	125	fpm/s/s	<b>Soft Start Jerk Rate.</b> Maximum jerk rate to roll into constant acceleration from a dead stop.
Soft Stop Time	0.2	30	1	sec	<b>Soft Stop Time.</b> <b>For Hydraulic Elevators</b> – time the motor is kept running after the valve is turned off. <b>For Traction Elevators</b> – time that zero speed is held until the brake is set.
Stop Decel Rate	5	225	50	fpm/s	<b>Stop Deceleration Rate.</b> Rate to bring the velocity from leveling speed to zero speed.
Stop On Pos Cnt	0	1	0	-	<b>Stop On Position Count.</b> Enable to stop the elevator on position pulse count. Used only for tapeless application. It requires CONS file setting to be enabled and readjustment of leveling sensors for it to work.
Top Speed	25	Contract Speed	0	fpm	<b>Top Speed</b> or contract speed of the car. If set to zero, or set to a value greater than top speed, it will use top speed in CONS file.

Field Variable	Min	Max	Initial	Units	Description
<b>Table 7-1: Car Motion</b>					
Torque Amount	0	100	0	gain	<b>Torque Amount.</b> Multiplier for the amount of torque proportional to the load. A value of 100 will give 100 percent torque with 100 percent load or 60 percent torque with an empty car.
Torque Down Amt	0	100	0	gain	<b>Torque Down Amount.</b> Torque Amount for down direction of travel. Multiplier for the amount of torque proportional to the load. A value of 100 will give 100 percent torque with 100 percent load or 60 percent torque with an empty car. If this value is set to zero then the Torque Amount parameter above will be used for both up and down direction.
Torque Ramp Tim	0	1	0	sec	<b>Torque Ramp Time.</b> The amount of time for the torque to ramp up prior to the elevator leaving the floor during pattern delay.
UL DeadZone Sel	0	15	3	-	<b>UL Dead Zone Sensor.</b> Adjusts the width of the door zone from four UL sensors. UL 1 is the outer most sensors whereas UL 4 is the inner most sensor. Each of the four bits, 0-3, of this parameter represents which UL sensor is being used. Bit 0 for sensor UL1 ... Bit 3 for sensor UL4. So a value of 3 will use sensor UL1 and UL2. (Used on tape applications). A value of 0 defaults to using UL1.

7.1.2 Car Brake Submenu

Field Variable	Min	Max	Initial	Units	Description
<b>Table 7-2: Car Brake</b>					
Brake Drop Del	0	5	0.1	sec	<b>Brake Drop Delay.</b> Delay time to drop the brake after the car has stopped and is dead level at the floor.
Brake Hold Volt	20	400	160	volts	<b>Brake Hold Voltage.</b> Voltage to hold the brake for the remainder of the run after <b>Brake Pick Time</b> expires.

Field Variable	Min	Max	Initial	Units	Description
<b>Table 7-2: Car Brake</b>					
Brake Opto Dly	0	7372	5500	3686/msec	<b>Brake Opto Delay.</b> The SCR Brake board trigger circuit uses optocoupler devices that have a turn on delay of roughly 1 millisecond but can vary from part to part and vary from different input filtering. This parameter is used to compensate for different turn on delays to start of triggering of the SCRs. Only change this value at the advice of a G.A.L. Technician.
Brake Pick Del	0	5	0	sec	<b>Brake Pick Delay.</b> Delay time to pick the brake after the run relay is energized.
Brake Pick Time	0.1	6	3	sec	<b>Brake Pick Time.</b> Duration of applied brake pick voltage before changing to the hold voltage.
Brake Pick Volt	20	400	230	volts	<b>Brake Pick Voltage.</b> DC Voltage to pick the brake. Brake voltage will start at <b>Brk Pick Start</b> voltage and then ramp to pick voltage.
Brk AC L-L Volt	80	300	240	volts	<b>Brake AC Line to Line Voltage.</b> AC input voltage to the brake board.
Brk Drop Rate	0	5	0	sec	<b>Brake Drop Rate Time.</b> Time value for brake to ramp from start voltage to zero.
Brk Drop Start	0	1	0	-	<b>Brake Drop Timing During Leveling.</b> 0 = Normal brake drop 1 = Early drop selected
Brk Drop Volt	0	200	0	volts	<b>Brake Initial Drop Voltage.</b> DC Voltage to start the brake drop. Brake voltage will start at this value and then ramp down to zero volts.
Brk Phase Inp	0	1	0	-	<b>Brake Phase Input.</b> 0 = Single phase 1 = 3 phase.

Field Variable	Min	Max	Initial	Units	Description
<b>Table 7-2: Car Brake</b>					
Brk Pick Rate	0	2	0	sec	<b>Brake Pick Rate Time.</b> Time value for brake to ramp from start voltage to <b>Brake Pick Volt</b> .
Brk Pick Start	0	400	0	volts	<b>Brake Pick Start Voltage.</b> Initial DC Voltage to pick the brake. Brake voltage will ramp to <b>Brake Pick Volt</b> .
Brk Relev Rate	0	2	0	sec	<b>Brake Relevel Rate Time.</b> Time value for brake to ramp from relevel start voltage to relevel voltage.
Brk Relev Start	0	400	0	volts	<b>Brake Relevel Start Voltage.</b> Initial DC Voltage to pick the brake on a relevel. Brake voltage will ramp to relevel voltage.
Brk Relev Volt	10	400	230	volts	<b>Brake Relevel Voltage.</b> Brake voltage applied on the brake coil during a relevel. This parameter is useful to have a partial brake lift on relevel. Relevel brake voltage will start at relevel start voltage and then ramp to relevel voltage.
Brk Resistance	0.1	500	283	Ohms	<b>Brake Resistance.</b> Resistance value measured on the brake coil in ohms.
EmBk Drop Dly	0	360	0	sec	<b>Emergency Brake Drop Delay.</b> Delay time to drop the brake after the car has stopped and is dead level at the floor.
EmBk Drop Rate	0	1.5	0	sec	<b>Emergency Brake Drop Rate Time.</b> Time value for brake to ramp from start voltage to zero.
EmBk Hold Volt	0	400	160	volts	<b>Emergency Brake Hold Voltage.</b> Voltage to hold the emergency brake for the remainder of the run after <b>Emergency Brake Pick Time</b> has expired.
EmBk L-L VAC	80	300	240	volts	<b>Brake AC Line to Line Voltage.</b> AC input voltage to the brake board.

Field Variable	Min	Max	Initial	Units	Description
<b>Table 7-2: Car Brake</b>					
EmBk Opto Dly	0	7372	5500	3686/msec	<b>Emergency Brake Opto Delay.</b> The SCR Brake board trigger circuit uses optocoupler devices that have a turn on delay of roughly 1 millisecond but can vary from part to part and vary from different input filtering. This parameter is used to compensate for different turn on delays to start of triggering of the SCRs. Only change this value at the advice of a G.A.L. Technician.
EmBk Phase In	0	1	0	-	<b>Emergency Brake Phase Input.</b> 0 = Single phase 1 = 3 phase.
EmBk Pick Rate	0	2	0	sec	<b>Emergency Brake Pick Rate Time.</b> Time value for emergency brake to ramp from start voltage to pick voltage. Only used if two brake boards are installed.
EmBk Pick Tim	0	10	3	sec	<b>Emergency Brake Pick Time.</b> Duration of applied emergency brake pick voltage before changing to the hold voltage. Only used if two brake boards are installed.
EmBk Pick Volt	0	400	230	volts	<b>Emergency Brake Pick Voltage.</b> DC Voltage to pick the emergency brake. Brake voltage will start at start voltage and then ramp to pick voltage. Only used if two brake boards are installed.
Pwl Bk Off Tim	0	5	0	sec	<b>Power Loss Brake Off Time.</b> When Pwl Bk On Tim and Pwl Bk Off Tim are set to a non zero values, the timers are used to pulse the brake contactor output on and off while recovering the car with Power loss brake option.
Pwl Brk On Tim	0	5	1	sec	<b>Power Loss Brake On Time.</b> When Pwl Bk On Tim and Pwl Bk Off Tim are set to a non zero values, the timers are used to pulse the brake contactor output on and off while recovering the car with Power loss brake option.

Field Variable	Min	Max	Initial	Units	Description
<b>Table 7-2: Car Brake</b>					
Relev Brk Delay	0	5	0	sec	<b>Relevel Brake Delay.</b> Time delay to lift the brake during a relevel.
Relev Brk LowV	0	1	0	-	<b>Relevel Brake Low Voltage.</b> Set to a 1 to relevel the car with the hold voltage to create a partial pick of the brake. Not used with electronic brake board.

7.1.3 Modified Motion Submenu

Field Variable	Min	Max	Initial	Units	Description
<b>Table 7-3: Modified Motion</b>					
EP Accel Rate	50	300	92	fpm/s	<b>Emergency Power Accel Rate</b>
EP Decel Jerk	50	480	125	fpm/s/s	<b>Emergency Power Decel Jerk rate</b>
EP Decel Rate	50	300	92	fpm/s	<b>Emergency Power Decel Rate</b>
EP Recov Speed	10	100	25	fpm	<b>Emergency Power Recovery Speed.</b> Recovery speed during emergency car recovery. Used when the emergency power recovery source can only provide enough power to bring the car to the floor in the direction of the load.
EP Roll Jerk	50	480	125	fpm/s/s	<b>Emergency Power Roll Jerk Rate</b>
EP SoftSt Jerk	50	480	125	fpm/s/s	<b>Emergency Power Soft Start Jerk</b>
EP Target Dist	1.2	25	12	inches	<b>Emergency Power Floor Target Distance</b>
EP Top Speed	10	Contract Speed	100	fpm	<b>Top Speed for Emergency Power</b>
ShFl Accel Rate	50	300	92	fpm/s	<b>Short Floor Acceleration Rate.</b> The constant acceleration rate to reach top speed.

Field Variable	Min	Max	Initial	Units	Description
<b>Table 7-3: Modified Motion</b>					
ShFI Decel Rate	50	300	92	fpm/s	<b>Short Floor Deceleration Rate.</b> The constant deceleration rate from top speed to leveling speed when stopping for a floor.
ShFI SoftSt Jrk	50	480	125	fpm/s/s	<b>Short Floor Soft Start Jerk Rate.</b> Maximum jerk rate to roll into constant acceleration from a dead stop.
Short FI Cntrl	0	7	0	-	<b>Short Floor Control.</b> 0 = Default is that the car relevels to the short floor. +1 = Car will make a run between very short floors instead of releveling. +2 = Short floor slowdown magnets between short floors (non-distance feedback). +4 = Mid Short floor slowdown magnets between short floors (non-distance feedback).
Short FI Dist	10	72	30	inches	<b>Short Floor Distance.</b> Any floor less than this distance is considered a short floor. The short floor flag gets set and if preopening is enabled, it can be specifically disabled for the short floor run.
ShrtFI Decl Jrk	50	480	125	fpm/s/s	<b>Short Floor Deceleration Jerk Rate.</b> Maximum jerk rate to roll from top speed to constant deceleration.
ShrtFI Roll Jrk	50	480	125	fpm/s/s	<b>Short Floor Rollover Jerk Rate.</b> Maximum roll jerk rate while rolling into top speed.
ShrtFI Targ Dis	1.2	25	8	inches	<b>Short Floor Target Distance.</b> Distance to start leveling mode into the floor. Increasing this distance will lower the jerk rate.

7.1.4 Car Timers Submenu

Field Variable	Min	Max	Initial	Units	Description
<b>Table 7-4: Car Timers</b>					
Adv Door En Tim	0	240	0	sec	<b>Advanced Door Enable Time.</b> Door open advance enable time to open the opposite door when operating with non-simultaneous doors. If there is a request for both doors, instead of waiting for the first open door to close completely before opening the second door, the second door starts to open after the advance door enable time while the first door is closing.
Att Buz Delay	0	900	60	sec	<b>Attendant Buzzer Delay.</b> Buzzer sounds if a hall call is entered and the car has not started moving within this delay time. This function is disabled when set to zero.
AttBuz Off Time	0	30	0	sec	<b>Attendant Buzzer Off Time.</b> Cycle off time to turn attendant buzzer on and off once attendant delay time function has been meet (See ATT Buz Delay). Buzzer will stay on continuously if this timer set to zero.
AttBuz On Time	1	30	5	sec	<b>Attendant Buzzer On Time.</b> Cycle on timer to turn attendant buzzer on and off once attendant delay time function has been meet (See ATTBuz Delay).
Auto Swg DO Dly	0	10	1	sec	<b>Auto Swing Door Open Delay.</b> Delay time to turn enable the auto swing door open output.
Car Call Dwell	1	60	2	sec	<b>Car Call Dwell.</b> Door open dwell time when answering a car call only.
CB Door Time	1	3200	60	sec	<b>Code Blue Door Time.</b> Door time for Code blue operation once elevator is at the emergency floor before EMS is energized
Chime onCC Time	0.1	2	0.2	sec	<b>Chime on Car Call Time.</b> Handicap buzzer on CC. Length of beep time.
CL Pulse Time	0	320	5	sec	<b>Car Lantern Pulse Time</b>



Field Variable	Min	Max	Initial	Units	Description
<b>Table 7-4: Car Timers</b>					
Door Delay Time	0	1.5	0	sec	<b>Door Delay Time.</b> Delay time between DO and DC to switch when opening or closing the door.
Door Fail Time	10	3200	25	sec	<b>Door Fail Time.</b> Time with power on the door without getting the door open limit.
EE Test Time	0	2	0.2	sec	<b>Electric Eye Test for Automatic Freight Doors</b>
EE Time-out	0	3200	40	sec	<b>Electric Eye Time-out Time.</b> If the Electric Eye or detector edge is on continuously for this amount of time, it will be flagged as timed-out and the controller will ignore the EE input and close the door on nudging. When set to zero, this feature is disabled.
Fault Time	0	10	2	sec	<b>Fault Time.</b> Delay time before allowing the car to run after a fault occurs.
FR DC Time-out	1	3200	1	sec	<b>Freight Door Close Time-out.</b> The amount of time prior to closing the doors on automatic freight door operation.
FR Pwr DO Time	0	30	1	sec	<b>Freight Door Power Door Open Time.</b> The amount of time to turn on the power door open relay on automatic freight door operation.
Gen/Lt/Fan Time	30	3200	360	sec	<b>Generator Run/Cab Light/Fan Time.</b> Length of time to leave the generator running or the Cab light and fan on after there is no longer a demand to run.
GOV Rst Pls Tim	1	15	2	sec	<b>Governor Reset Pulse Time</b>
Grip/EBK Rset T	0	20	4	sec	<b>Gripper/Emergency Brake Reset Time.</b> The amount of time it takes for the rope gripper to reset on power-up.
Hall Call Dwell	1	60	4	sec	<b>Hall Call Dwell.</b> Door open dwell time when answering a hall call or both a hall and car call.

Field Variable	Min	Max	Initial	Units	Description
<b>Table 7-4: Car Timers</b>					
Hall Lant Dly	0	15	0	sec	<b>Hall Lantern Delay Time.</b> By default, when set to zero, hall lanterns go off as soon as the car starts to slow down to arrive at a floor. When set to a nonzero value, this will be used as a timer for the hall lantern to go off prior to arriving at the floor. For example, if set to three seconds, hall lanterns will turn on approximately three seconds before the car arrives to the floor regardless of the speed of the car. We recommend to set this parameter for high speed cars.
Handicap Dwell	1	120	25	sec	<b>Handicap Dwell.</b> Extended door time from pressing the ED button in the car.
HEOF Auto Rst T	0	3200	0	sec	<b>HEOF Auto Reset Time.</b> When the hall elevator off function is activated from the HEOF input being turned on, the car will be taken out of service until the input is turned off. Once the input is off, the car will stay out of service until this timer times out.
IND Rcl2Lby tmr	10	60	20	sec	<b>Independent Recall to Lobby Timer.</b> Recall delay for car in independent when 'IND Rcl to Lby ' is set.
Lant Off Time	0	2	0.2	sec	<b>Lantern Off Time.</b> Used for double stroke gongs. The lantern off time is the delay time after the lantern first turns on until it turns off.
Lant On Time	0	2	0.7	sec	<b>Lantern On Time.</b> Used for double stroke gongs. The lantern will turn on, turn off and then turn on again. The Lantern on time is the delay time from when the lantern first turns on until it turns on the second time.
Learn HW Stall	1	3200	30	sec	<b>Automatic Hoistway Learn Stall Time.</b> The time required for a hoistway learn is calculated by the number of floor at an average height of 12.5 feet. This stall time value is added to the calculated value for the maximum time allowed for the auto hoist way learn to run. If floor heights are taller or if there is a blind shaft, this timer may need to be increased to the additional floor height times 1.2 (multiplier for car running at 30fpm). For a blind shaft of 50 feet then use a timer value of $50 * 1.2 = 60.0$ seconds.

Field Variable	Min	Max	Initial	Units	Description
<b>Table 7-4: Car Timers</b>					
Lobby Dwell	1	60	5	sec	<b>Lobby Dwell.</b> Door open dwell time for a car at the lobby.
ManDoor Buz Dly	0	900	0	sec	<b>Manual Door Buzzer Delay.</b> On a car with manual doors, sound the buzzer if the door is left open and a call is entered after this time delay. This function is disabled when set to zero.
Max Door Hld T	0	3200	0	sec	<b>Maximum Door Hold Time</b> to be allowed when the extended dwelling input (ED) is pressed. If set to zero, there will be no limit on how long the car will be held on ED. When set to a value, this will be the maximum allowed time for the car to held by ED input, then car will go on regular dwelling timers (car or hall call dwelling timers)
Non Interfer T	1	60	2	sec	<b>Non-Interference Time.</b> Time between when you stop and when you can run again.
Nudging Time	20	3200	60	sec	<b>Nudging Time.</b> Delay time for a door to be held before going into nudging.
OSER BTFI r Tim	0	900	60	sec	<b>Out of Service Between Floors Time.</b> Timer to control the OSERL output. Used with <b>OSERL Control Option 1</b> for 'between floors for over a minute' set to 2.
OSER Ncall Tim	0	900	600	sec	<b>Out of Service Not Responding to Calls Time.</b> Timer to control the OSERL output. Used with <b>OSERL Control Option 1</b> for 'not responding to calls' set to 1.
OSER Sopen Tim	0	900	60	sec	<b>Out of Service Safety String Open Time.</b> Time to control the OSERL output. Used with <b>OSERL Control Option 1</b> for 'SS open' set to 4.
Pas Chime Time	0.2	2	0.5	sec	<b>Floor Passing Chime Time.</b> Length of time the floor passing chime will sound when a floor is passed.
RC dropfail Tim	0.5	5.5	0.5	sec	<b>Retiring Cam Drop Fail Time.</b> Retiring cam drop fail safe delay for manual doors. Time it waits when car arrives to the floor before it drops the output.

Field Variable	Min	Max	Initial	Units	Description
<b>Table 7-4: Car Timers</b>					
RC Pick Delay	0	7	0	sec	<b>Retiring Cam Pick Delay.</b> The amount of delay time for the retiring cam to pick once the doors are closed.
Relev Dly Tim	0	2	1	sec	<b>Relevel Delay Time.</b> The amount of delay time before the car will relevel. This would be used for jobs that have excessive rope stretch.
Reset Time	0	10	5	sec	<b>Reset Time.</b> Delay time in the reset mode before allowing the car to run.
RTL Dwell Time	1	60	8	sec	<b>Return To Lobby Dwell Time.</b> If Return To Lobby is set to cycle doors at the lobby, use this timer to control how long they will dwell before closing in return to lobby mode.
Run Cycle Time	0	300	0	hours	<b>Run Cycle Time.</b> Used to initiate a run when the elevator has been sitting idle for a period of time. Used for jobs that have high friction bearing machines.
Sabb Buzz Delay	1	10	5	sec	<b>Sabbath Door Buzzer Timer Prior to Doors Closing:</b> Jobs where the light curtain is disabled in Sabbath operation require a buzzer prior to the door closing sequence. This timer warns people the light curtains are about to be enabled (output name: SABUZ)
Sabbath Dwell	1	60	10	sec	<b>Sabbath Door Dwell Time.</b> Car will wait this amount of time on every floor for Sabbath operation except at the lobby where it will follow the handicap dwell door time (separate timer).
Sec Disable Tim	0	3200	0	sec	<b>Security Disable Time.</b> This timer is used with a security disable input button at the lobby. When the button is pressed, the car call security is disabled for the time value set from this parameter.
Short Dwell Tim	0	60	1	sec	<b>Short Door Dwell Time.</b> Door open dwell time when the doors re-open on a door open button, electric eye, safety edge or door hold button.

Field Variable	Min	Max	Initial	Units	Description
<b>Table 7-4: Car Timers</b>					
Shutdn Alarm T	5	1500	120	sec	<b>Shutdown Alarm Timer</b>
Stall Time	20	3200	60	sec	<b>Stall Time.</b> Maximum time a run is requested but the car is not moving.
VIP Door Time	1	3200	20	sec	<b>VIP Door Time.</b> The amount of time the car will park at the VIP recall floor prior to going to automatic service.
Y Delta Time	1	5	1.5	sec	<b>Y-Delta Time.</b> Transfer time to change motor from Y start to Delta run. Timer also used for DEL or MCX turn on time with controllers without y-delta starters.

7.1.5 Car Options Submenu

Field Variable	Min	Max	Initial	Units	Description
<b>Table 7-5: Car Options</b>					
# Load Sensors	1	16	20	sen	<b>Number Of Rope Load Sensors</b> to use with new Micelect load weigher.
Arrival Lant	0	1	0	-	<b>Arrival Lantern.</b> 1 = activate lant/gong without onward call.
Behind CC Canc	0	1	0	-	<b>Behind Car Call Cancel.</b> When enabled the elevator will not latch any car calls in the opposite direction of travel.
Binary Preset	0	1	0	-	<b>Binary Preset.</b> 0 = Update the car position count based on the binary preset when the car recovers into a floor. 1 = Always update the car position count based on binary preset when the position doesn't not match.

Field Variable	Min	Max	Initial	Units	Description
<b>Table 7-5: Car Options</b>					
Brake Lift Sw	0	2	1	-	<p><b>Brake Lift Switch.</b>                      If set to 1 or 2 a brake lift switch fault is detected.                      0 = The Brake switch is ignored.                      1 = The car is prevented from running if the brake does not drop or if the brake did not pick on the previous run. The car is allowed to run after the brake drops.                      2 = The rope gripper will set if the brake does not drop and then can only be reset by placing the car on inspection and back to automatic.</p>
Cab Lant Ctrl	0	2	0	-	<p><b>Cab Lantern control.</b> The default is for the cab lanterns to go off when the door is fully open. This parameter allows the cab lanterns to go off earlier.                      +1 = Ring cab lanterns as soon as door starts to open                      +2 = Ring the cab lanterns when the door reaches DPM point.</p>
Cl Gate No Pref	0	1	0	-	<p><b>Close Gate (Swing Door)</b> when No Onward Preference. The gate on a swing door normally stays open until a call is placed. This bit causes the gate to close while the car is sitting at the floor.</p>
COP/Remote CC	0	7	0	-	<p><b>COP/Remote Car Call Select.</b> 0 = Both COP and Remote Car Call Station used to enter calls. +1 = Separate: COP only or Remote CC only used to enter car calls. +2 = C-R: Car calls entered on the COP sets the acknowledgment light on the Remote station. +4 = R-C: Car calls entered on the Remote station sets the acknowledgment light on the COP.</p>
COP/Remote Dis	0	31	0	-	<p><b>COP/Remote Disable.</b>                      +1 = Up Direction Disable COP                      +2 = Down Direction Disable COP                      +4 = Up Direction Disable Remote Panel                      +8 = Down Direction Disable Remote Panel                      +16 = EP Recall Disable Remote CC</p>
DCB Canc Dwell	0	1	0	-	<p><b>Door Close Button Cancel Dwell Time.</b> When this parameter is set to 1 we do not allow DCB to cancel the door dwell time. It basically disables DCB to shorten door dwell time.</p>

Field Variable	Min	Max	Initial	Units	Description
<b>Table 7-5: Car Options</b>					
DO No Actv DOL	0	1	0		<b>Door Open Output when not Active DOL.</b> 0 = When the door is fully open and hits the DOL, the DO is turned off and stays off even if the door drifts off of DOL. 1 = With this bit set, the DO output will turn on any time the DOL is lost.
DOB Over Nudg	0	1	0		<b>DOB Over Nudging.</b> If set the door open button will open the door when the door is nudging closed.
DoorOpenL Ctrl	0	16	0	-	<b>Door Open Light Control.</b> The way 'DoorOpenL Ctrl' parameter works is as below: +1 = Set OPENL on phase 1 completed +2 = Set OPENL on RTL return to lobby +4 = Set OPENL on emp returned home with doors open, also sets OPENL on emp and selected to run +8 = Set OPENL on when Lobby Floor +16 = Set OPENL all the time
Double Stroke	0	1	1	-	<b>Double Stroke Gong Selection.</b> Select 1 or 2 gongs for down hall calls. 0 = 1 gong 1 = 2 gongs.
Drive Rdy Flts	1	10	5	count	<b>Drive Ready Fault Reset Count.</b> Number of times the drive can be reset in a 20 minute time period.
DZ gripper ctl	0	1	0	-	<b>DZ Gripper Trip Control.</b> 0 = The gripper will detect "out of the door zone" from DZ only. 1 = The controller will use DZ anded with DZA (both activated) which changes the trip zone from 2 inches to 6 inches.
EE Cancel Dwell	0	1	0	-	<b>Electric Eye Cancel Dwell.</b> By turning this parameter on you disable the short dwelling door time from the electric eye signal (EE). By default the short dwelling time is enabled.

Field Variable	Min	Max	Initial	Units	Description
<b>Table 7-5: Car Options</b>					
EM Brake Sw	0	1	0	-	<b>Emergency Brake Switch Control</b> 0 = Don't start if brake switch does not pick 1 = Ignore brake switch on start
Enc Dir Flt Dis	0	1	0	-	<b>Encoder Direction Fault Disable.</b> 0 = Enables fault 1 = Disables fault
GOV Gripper/EBK	0	1	0	-	<b>Governor Switch Gripper/Emergency Brake Trip Control.</b> 0 = Sets and latches a gripper fault immediately when the governor switch is opened. 1 = Latches the gripper fault only if the governor switch is opened while the car is traveling at contract speed or above 150 fpm. When the gripper fault is latched it must be reset from the LCD interface for the car to run.
Griper/EBK Buz	0	1	0	-	<b>Gripper/Emergency Brake Buzzer.</b> Turn on buzzer if there is an active rope gripper or emergency break fault
Gripper/EBK Trip	0	3	3	-	<b>Gripper/Emergency Brake Trip.</b> 0 = Off+1 = Safety Processor Speed+2 = Overspeed
HB/PI Dis NV FI	0	1	0	-	<b>Handicap Buzzer/PI Display Control.</b> When set to 1, do not sound HB or update floor PI when passing an invalid floor.
Hndcap Time Flr	Bottom Floor	Top Floor	1	floor	<b>Handicap Time Floor.</b> If the job is configured to have an extended door input at a hall station, this parameter configures the floor number when parameter will change door timing. Follows <b>Car Timers &gt; Handicap Dwell</b> timer. It will operate for EDHL only
Invert BLS	0	1	0	-	<b>Invert Brake Lift Switch.</b> When set inverts the logic for the brake lift switch to use a normally closed switch instead of normally open.



Field Variable	Min	Max	Initial	Units	Description
<b>Table 7-5: Car Options</b>					
Invert CLF	0	1	1	-	<b>Invert the logic for the Car Light / Fan.</b> 0 = Car light / fan is normally open. 1 = Car light / fan is normally closed.
Invert ISER	0	7	0	-	<b>Invert In Service Output.</b> 1 = The in service light output is turned off when the car is in service instead of turned on. 2 = The ISER output will function as an elevator in use light. 4 = The output functions as out of service from a shutdown and does not include independent, inspection or recovery mode.
Lant Pref Dly	0	3	0	sec	<b>Lantern Preference Change Delay.</b> When the direction preference for the elevator changes, we clear the lanterns and wait for this amount of time before the lanterns are turned on again.
Level Fault Cnt	3	10	3	count	<b>Level Fault Count.</b> Maximum count of consecutive relevel tries when a relevel error is detected. A relevel error is detected when the brake is dropped and the car moves out the level zone.
Leveling Fault	0	1	0	-	<b>Leveling Fault Effect.</b> 0 = Drop everything 1 = Set emergency brake or gripper when a leveling fault occurs. It will have to be manually reset.
Lim Dir Flt Dis	0	1	0	-	<b>Limit Direction Fault Disable.</b> Controller confirms the car direction of travel as it hits the terminal limits. 0 = Enables fault 1 = Disables fault
Load Rope Bal %	0	100	5	%	<b>Load Rope Balance Percent</b>
Load Wg Cal Fl	0	Top Floor	0	Floor	Load Weigher Calibration Floor. This parameter selects the destination floor where the car will calibrate the load weigher. If set to zero, the car will look at the load empty table and select the floor with the lowest value. IF multiple floors have the lowest value, it will pick the low value floor closest to a terminal floor.

Field Variable	Min	Max	Initial	Units	Description
<b>Table 7-5: Car Options</b>					
LobbyLan NCU/IR	0	1	0	-	<b>Lobby Lantern NCU/IR.</b> 0 = Light the lanterns on IR service at each floor. The lantern will not light at the lobby if next up operation is selected because the IR car will not be selected to be the next up car. 1 = The IR car will light the lantern at all the floors and the lobby even with the system on Next Up operation.
Min Door Tim En	0	1	0	-	<b>Minimum Door Time Enable.</b> When set to 1, the minimum door time for a car call or a hall call is set from the car or hall call dwell timers and cannot be shortened by the Door Close button.
NCU Lant Ctrl	0	3	0	-	<b>Next Up Direction Lantern Control.</b> +1 = Turn off hall lantern after next up time. +2 = Turn off cab lantern after next up time.
NCU Pref Ctrl	0	1	0	-	<b>Next Up Preference Control.</b> When set allows direction preference to change before the door starts to close after the next up door time.
No HC Door Reop	0	3	0	-	<b>No Hall Call Button Door Reopen.</b> When set do not reopen the door from a hall call.
Non-Simul Doors	0	2	0	-	<b>Non-Simultaneous Doors.</b> 0 = Both front and rear doors will open at the same time if there is a demand at both the front and rear openings. 1 = Front doors will open first before the rear doors open if there is a demand to open. 2 = The rear doors will open first before the front doors open if there is a demand to open.
Nudge Dis Ctl	0	7	0	-	<b>Nudging Disable Control.</b> +1 = Do not turn on the NUD output when doors are in nudging close mode, basically you are disabling nudging output. +2 = When doors are in nudging close mode and SE input is ON, keep doors open and also keep FB/NB output latched. +4 = Sound the nudging buzzer but do not close the doors on nudging.

Field Variable	Min	Max	Initial	Units	Description
<b>Table 7-5: Car Options</b>					
Nudge No Calls	0	1	0	-	<b>Nudge with No Calls.</b> If set to a 1 the doors will close on nudging even if the elevator has no onward calls.
OSERL OutCtrl 1	0	7	0	-	<b>Out of Service Light Control</b> +1 = Not responding to calls +2 = Between floors for over a minute +4 = SS open. When this parameter as well as <b>OSERL OutCtrl 2</b> is set to zero, the output will just operate as an Out of service light.
OSERL OutCtrl 2	0	1	0	-	<b>Out of Service Light Control 2</b> + 1= Alarm.  When this parameter as well as OSERL OutCtrl 2 is set to zero, the output will just operate as an Out of service light.
Preopen Doors	0	3	0	-	<b>Preopen Doors.</b> +1 = Will enable preopening of the doors. If retiring cam used with auto door, RCM will also turn on at the preopening point. +2 = Exclude short floors.
Rad Pos Ind	6	48	6	inches	<b>Radial Position Indicator.</b> Used for radial Position indicator output. It adjusts the range for the distance from the floor where the position indicator outputs should turn on and off
RCF out enable	0	1	0	-	<b>Retiring Cam for Freight Output Enable.</b> When you turn on this parameter we show a retiring cam <b>output</b> in controller, RCF, that mirrors the signal from RCM. You need to reboot CPU every time you change this parameter for changes to take effect.

Field Variable	Min	Max	Initial	Units	Description
<b>Table 7-5: Car Options</b>					
RCM Control	0	3	0	-	<b>Retiring Cam Control.</b> 1 = Hold the retiring cam up at the floor if there is no pilot to open the door (manual doors). The retiring cam will drop after 5 minutes. 2 = RCM output turns on when DZ hit to advance the RCM ahead of the door open (auto door with retiring cam) otherwise the default is that RCM turns on when dead level. If preopening is set, RCM and DO turn on when DZ hit.
Secnd Riser Lant	0	1	0	-	<b>Second Riser Lantern.</b> Turn on cab lantern only when IR call answered. If this parameter is set, cab lanterns will only turn on when answering second riser calls.
Slip Det Dis	0	1	0	-	<b>Slip Velocity Difference Disable.</b> 0 = Enables fault 1 = Disables fault. Can only be disabled with code previous to A17.1 2010.
Slip Vel Diff	0	300	150	fpm	<b>Slip Velocity Difference Fault Trip Value.</b> This parameter determines Maximum allowable difference between Safety processor speed and controller speed.
SPB Dir Flt Dis	0	1	0	-	<b>SPB Direction Fault Disable.</b> 0 = Enables fault 1 = Disables fault
ULDL DirFlt Dis	0	1	0	-	<b>UL/DL Direction Fault Disable.</b> Controller confirms the car direction of travel when it passes the UL and DL door zone limits. 0 = Enables fault 1 = Disables fault
Vel Diff Dis	0	1	0	fpm	<b>Velocity Difference Fault Disable.</b> 0 = Enable sfault 1 = Disables fault

Field Variable	Min	Max	Initial	Units	Description
<b>Table 7-5: Car Options</b>					
Velocity Diff	50	300	150	fpm	<b>Velocity Difference.</b> Maximum velocity difference between Encoder feedback and Demand Velocity. When the difference exceeds this setting, 'Velocity Diff Fault' will occur.

7.1.6 Service Options Submenu

Field Variable	Min	Max	Initial	Units	Description
<b>Table 7-6: Service Options</b>					
Access Bot Fl	Bottom Floor	Top Floor	1	floor	<b>Access Bottom Floor.</b> Floor for bottom access
Access Door Cls	0	1	0	-	<b>Access Door Close.</b> When on access operation the car runs with the Door Lock and GS open. By turning this parameter on, the car needs to have the gate switch signal ON in order to run. It should be used on hoistways where the car door will physically hit something if moved on access operation
Access Top Fl	Bottom Floor	Top Floor	2	floor	<b>Access Top Floor.</b> Floor for top access
Att Buz ctrl	0	1	1	-	<b>Attendant Buzzer Control.</b> 0 = Hall Calls only 1 = Hall Calls and Car Calls
Att CC from HC	0	1	0	-	<b>Attendant Car Call from Hall Call.</b> When set to 1 and the car is on Attendant service the respective car call will register when a hall call is registered.
CCPBS on Gp Sec	0	1	0	-	<b>CCPBS On Group Car Call Security.</b> This variable enables Car Call Push Button Security with group car call lockout switches. The configuration file setting for security type and car call push button security must also be set.
CCS on Sabbath	0	1	0	-	<b>Car Call Security on Sabbath.</b> When this parameter is enabled, Sabbath car calls will not latch on floors that have been secured using car call lockouts security

Field Variable	Min	Max	Initial	Units	Description
<b>Table 7-6: Service Options</b>					
CEOF Control	0	7	0	-	<b>Car Elevator Off Options:</b> +1 = Recall +2 = Keep Door Open +4 = Turn off CLF (Car Light / Fan)
CEOF Control 2	0	15	0	-	<b>Car Elevator Off Options 2:</b> +1 = Keep doors Closed (do not cycle on reversal) +2 = Do not blink Elevator Off Light +4 = Elevator Off Auto Reset With Timer +8 = Enable Elevator Off Light to indicate the car finished recall of elevator off mode
DOB Over Sec	0	5	0	-	<b>DOB Override Security.</b> This parameter allows the car to open the door at a secured floor when the car is secured from the following conditions: 1 = The DOB will be allowed to open the door at any secured floor. 2 = The DOB can open the door at floors secured from group security floor mask table.3 = Allows the DOB to open the front door at floors secured by car call lockout security (switches or card reader).4 = Allows the DOB to open the rear door at floors secured from rear car call lockout security.5 = Allows the DOB to open the door at floors locked out by group security floor mask tables when the car is also on independent.
Door Hold Msg	0	1	0	-	<b>Door Hold Message.</b> Set to enable Extended Door Time Message Indicator in CE Driver board
Elev Off Ret Fl	0	Top Floor	0	floor	<b>Elevator Off Return Floor.</b> Related to HEOF input. <b>This setting is to be used in conjunction with 'Elev Off Ctl = +1'.</b> If the elevator is configured to recall, this parameter will determine what floor the car should be recalled to in elevator off mode. If Parameter is set to zero, car will be returned to the Lobby.
Elv Off2 Ret Fl	0	Top Floor	0	Floor	<b>Hall Switch Elevator Off 2 Return Floor</b>

Field Variable	Min	Max	Initial	Units	Description
<b>Table 7-6: Service Options</b>					
Handicap Load	0	100	40	%	<b>Handicap Load (Car Capacity).</b> Percent load when above this value, the car may not have enough room for a person in a wheelchair. Cars with loads below this value would be given a preference to get an assignment at a floor requested by a handicap person.
HC Acknwldg Bzz	0	1	0	-	<b>HC Acknowledge Attendant Buzzer</b> - Buzz once ( for one sec) every time a call comes in. 0 = Disable 1 = Enable
HEOF Control	0	7	0	-	<b>Hall Elevator Off Control.</b> +1 = Recall car when key switch activated. +2 = Keep door open at the shutdown floor. +4 = Allow the cab light and fan to time-out even though the door is open but the car is shut down.
HEOF Control 2	0	15	0	-	<b>Hall Elevator Off Options 2:</b> +1 = Keep doors Closed (do not cycle) +2 = Do not blink HEOFL +4 = Auto Reset when input off and timer expires. +8 = Use HEOFL to indicate car finished recall.
HEOF Control 3	0	1	0	-	<b>Hall Elevator Off Options 3.</b> +1= Only activate if doors are closed. See other Hall Elevator Off Options as well.
HEOF Over Ind	0	1	0	-	<b>Hall Elevator Off Override Independent</b> 1 = Wait for timer to expire and then recall the car
IND Door Cl CC	0	1	0	-	<b>Independent Door Close Car Call.</b> Enable to close the doors from a car call when the elevator is on independent.
Ind Over Sec	0	7	0	-	<b>Independent Overrides Security.</b> 1 = Allows independent service to override security car call lockouts. 2 = Override Security Floor Mask configurations 4 = Override remote car call station.

Field Variable	Min	Max	Initial	Units	Description
<b>Table 7-6: Service Options</b>					
IND Rcl to Lby	0	1	0	-	<b>Independent Recall to Lobby.</b> Forces the car to recall to the lobby when on independent and no calls are made
Ins Door Close	0	1	0	-	<b>Inspection Door Close.</b> When set to 1, the door close output will turn on when the up or down inspection run button is pressed.
INSEC Outp Ctl	0	1	0	-	<b>INSEC - In Security Output Invert.</b> Output located on the car call security Board, 0 = Disable 1 = Enable
Load Antinuisan	0	100	20	%	<b>Load Anti-nuisance.</b> Percent load when below this set point will cause the car to drop its car calls. This function is disabled when set to zero.
Load Bypass	0	100	60	%	<b>Load Bypass.</b> Percent load when above this set point will cause the car to bypass hall calls. This function is disabled when set to zero.
Load Dispatch	0	100	40	%	<b>Load Dispatch.</b> This set point is used as a trigger to activate Up Peak operations in the group. Each time the car leaves the lobby with a load greater than this value, the group will increment the Up Peak Trigger. This function is disabled when set to zero.
Load Overload	0	125	110	%	<b>Load Overload.</b> Percent load when above this set point will cause the car to go on overload operation (sit at the floor with the door open and the overload light on). When the load goes below this value, the car will automatically return to service. This function is disabled when set to zero.
LW Anti-nuisan	0	50	0	count	<b>Load Weighing Anti-nuisance.</b> Set to the maximum number of car calls that can be entered before all car calls are cancelled without the load switch LWA input on. Once the load switch is on, all car calls will stay latched. If set to 0, this function is disabled.



Field Variable	Min	Max	Initial	Units	Description
<b>Table 7-6: Service Options</b>					
Manual Dir En	0	4	0	-	<b>Attendant Manual Direction Enable.</b> 1 = Works in conjunction with the ATTUP and ATTDN to determine direction of travel. 2 = Reads the ATTUP input and use it as a START button. 4 = Will not allow car calls to be registered until the door is fully closed.
No Psg Run Cnt	0	10	0	count	<b>No Passenger Run Count.</b> When set to a number other than zero, the car call antinuisance feature is activated. This count is the number of times the car will run from a car call without detecting that a passenger has broken the detector edge. Once the count is reached, all remaining car calls will be cancelled.
PI Serv Msg 1	0	Max Service	0	Service Number	<b>PI Service Message 1.</b> When the car service matches this number, user message 1 is sent to the PI display. This will correspond to user PI display message 17.
PI Serv Msg 2	0	Max Service	0	Service Number	<b>PI Service Message 2.</b> When the car service matches this number, user message 2 is sent to the PI display. This will correspond to user PI display message 18.
PI Serv Msg 3	0	Max Service	0	Service Number	<b>Service Message 3 Display.</b> Used for Custom messages. Need to be programmed by CE electronics and GAL for special messages.
Return To Lobby	0	7	0	-	<b>Return to Lobby Option.</b> +1 = Cycle door at lobby +2 = Cancel car calls when activated +4 = Cycle door on reversal.
RTL Door Selct	0	2	0	-	<b>Return To Lobby Door Select.</b> This variable allows you to specify door open type on 'Return to Lobby' service. 0 = The car will open only front door 1 = The car will open only rear doors 2 = The car will open both front and rear

Field Variable	Min	Max	Initial	Units	Description
<b>Table 7-6: Service Options</b>					
Sabbath Dis Ctl	0	7	0	-	<b>Sabbath Disable Control Variable</b> - Add all numbers of the features you want to disable while in Sabbath operation: +1 = Pls +2 = Lanterns +4 = Directional arrows
Sabbath En Ctl	0	7	0	-	<b>Sabbath Enable Control Variable.</b> Set to zero disables all options. +1 = Allow IR momentarily to override Sabbath operation. +2 = Lobby Dwell time in Sabbath follows handicap door dwell time instead of the lobby dwell time. +4 = Wait until car is at lobby to turn off Sabbath operation
Sabbath En Ctl2	0	3	0	-	<b>Sabbath Enable Control:</b> +1 = When the car is placed on Sabbath operation, it waits to go to the lobby before switching to Sabbath Operation +2 = Uses the cab lanterns as directional arrows. This allows people on the hallway to know direction of travel for the elevator
Sabbath Mode	0	1	0	-	<b>Sabbath Collective Mode.</b> 0 = Down collective car calls 1 = Up collective car calls.
Sec Reassign CC	0	3	0	-	<b>Security Reassign Car Call.</b> Re-assign secured car call to opposite door. <b>Used with security configuration cons.dat file setting: cons[SecFICfg] = 2.</b> 0 = Disabled +1 = If front CC are secured, reassign them as rear +2 = If rear CC are secured, reassign them as front.
Sec Recall 2	0	2	0	-	<b>Security Recall Control 2.</b> 0 = Out of group on first recall. 1 = Out of group on all recalls. 2 = No out of group recalls.
Security Floor	0	Top Floor	1	floor	<b>Security Floor.</b> The security recall floor. This is the floor where the security guard would be stationed. <b>This floor would not be locked out when on security.</b>

Field Variable	Min	Max	Initial	Units	Description
<b>Table 7-6: Service Options</b>					
Security Recall	0	15	0	-	<p><b>Security Recall Selection.</b>                      0 = No Recall                      +1 = Recall to Security Floor on activation of security                      +2 = Cycle front door once recalled to the Security Floor.                      +4 = Cycle rear door once recalled to the Security Floor.                      +8 = Always recall to security floor after each run.</p>
Service LT CTL	0	30	0	Service Number	<p><b>Service Light Control.</b> When the configuration file parameter <b>cons[servOUT]</b> is set to 1 or 2, the service output SERVO will turn on when the car service matches the car service number in this parameter.</p>
SR CCSec by Dir	0	2	0	-	<p><b>Second Riser Car Call Security by Direction.</b> Allows calls in the one direction but disables them in the other.                      1 = Allow calls in the up direction (above the floor) but disable them going down                      2 = Allow calls in the down direction (below the floor) but disable then going up.</p>
Stop At Lobby	0	15	0	-	<p><b>Stop at Lobby.</b>                      0 = Do not automatically stop at lobby,                      +1 = The car will stop at the lobby when the car is traveling up and the car is below the lobby floor.                      +2 = The car will stop at the lobby when the car is traveling down and the car is above the lobby floor.                      3 = The car will stop at the lobby when traveling in either direction.                      +4 = Stop at lobby with any onward call past the lobby.                      +8 = Recall to the lobby</p>
Vip Lant Ctrl	0	3	0	-	<p><b>VIP lantern control:</b>                      0 = Do not ring lanterns on VIP                      1 = Ring up or down lantern at VIP floor when the door is fully open                      2 = Ring up or down lantern at VIP floor before the door is opened</p>

Field Variable	Min	Max	Initial	Units	Description
<b>Table 7-6: Service Options</b>					
VIP multi call	0	1	0	-	<p><b>VIP Multiple Calls.</b>                      0 = VIP feature works as single call                      1 = The car will be allowed to make multiple VIP calls until no more car calls are entered and until the VIP sequence time-out timer is expired.</p>

7.1.7 Emergency Services Submenu

Field Variable	Min	Max	Initial	Units	Description
<b>Table 7-7: Emergency Services</b>					
ALT Fire Floor	Bottom Floor	Top Floor	2	floor	<b>Alternate Fire Floor.</b>
Alt Rcl FS Off	0	3	0	-	<p><b>Alternate Floor Recall Fire Service Off.</b>                      +1 = Have the elevator recall back to the alternate floor when the lobby fire switch is turned to the off position and car recalled to the main fire floor.                      +2 = Allows the car to return to the alternate landing even if sensor was reset</p>
Aux. Fire Sw.	0	1	0	-	<b>Auxiliary Fire Switch.</b> When set, the controller expects an auxiliary hall fire switch to be used.
CB Buzzer Ctrl	0	1	0	-	<p><b>Code Blue Buzzer Control:</b>                      1 = Turn on while in code blue recall</p>
CB over FS	0	1	0	-	<p><b>Code Blue Over Fire Service:</b>                      +1 = Enable to have code blue prevent car from recalling in FS</p>
CB Over Ind	0	1	0	-	<p><b>Code Blue Override Independent</b>                      1 = Wait for timer to expire and then recall the car</p>
CB single call	0	1	0	-	<p><b>Code Blue Single Car Call.</b>                      0 = Car on Code Blue operation allows multiple car calls on Hospital Service.                      1 = Allow only a single call once placed on Hospital Service.</p>

Field Variable	Min	Max	Initial	Units	Description
<b>Table 7-7: Emergency Services</b>					
Cl Door F1 Rcl	0	1	0	-	<b>Close Door after Fire phase 1 Recall.</b> When set to 1, elevator will close the doors after phase 1 recall and reopen from a hall call (Denver Fire service amendment).
Em Power Floor	Bottom Floor	Top Floor	1	floor	<b>Emergency Power Recall Floor.</b>
EMS/HS after CB	0	1	0	-	<b>EMS(Emergency Medical Service)/HS(Hospital Service) after Code Blue.</b> This is a Code Blue bypass control. 0 = Car goes from Auto to Hospital service, bypassing the code blue sequence, when EMS switch is turned on. 1 = Hospital service only activates after a code blue recall.
EP Recovery Dir	0	1	0	-	<b>Emergency Power Recovery Direction.</b> Recover to the nearest floor on emergency power. 0 = Based on movement of the car when brake is picked. 1 = Based on load weighing device. Used when the emergency power recovery source can only provide enough power to bring the car to the floor in the direction of the load.
EPS Sel No Grp	0	2	0	-	<b>Emergency Power Selection Switch Operation</b> with no Group active. 0 = Run Automatic 1 = Recall first and then run automatic 2 = Recall only; do not run after recall.
F1 DC Time-out	10	60	20	sec	<b>Fire Phase 1 Door Close Time-out.</b> The amount of time it will take before the car doors start to close while the car is on Independent or Attendant service prior to recalling the elevator on Fire Phase 1.
F1 Door Dwell	1	90	60	sec	<b>Fire Phase 1 Door Dwell Time.</b> Fire Service Phase one complete dwell time when 'Cl Door F1 Rcl' parameter is set. (Denver FS phase1 dwell time)

Field Variable	Min	Max	Initial	Units	Description
<b>Table 7-7: Emergency Services</b>					
F2 DOB ovr DCB	0	1	0	-	<b>Fire Phase 2 Door Open Button Overrides Door Close Button.</b> 1 = Allows Door Open Button to override Door Close Button on phase 2. 2 = Miami.
Fire Main Floor	Bottom Floor	Top Floor	1	floor	<b>Fire Main Floor.</b>
Fire Option	0	3	0	-	<b>Fire Option. Recall Reset Selection:</b> 0 = Reset fire service phase 1 after hall switch is turned off and car returns to fire floor. 1 = Reset phase 1 immediately after hall switch is turned off.
Fire Option 2	0	3	1	-	<b>Fire Option 2.</b> +1 = Initiate a phase 2 recall only when the door is open (Chicago fire). +2 = Disable flashing FL on phase 2 (Chicago fire).
Fire Sw Loc	0	4	0	-	<b>Fire Switch Location.</b> Location of fire hall switch. 0 = Main/Alt Front 1 = Main Rear/Alt Front 2 = Main Front/Alt Rear 3 = Main/Alt Rear 4 = Set from Dispatcher Car selection.
FireL Emer Pwr	0	1	1	-	<b>Fire Light Control During Emergency Power –</b> Enable to cause the fire light FL to turn off if the car is not selected to run.
FireL OTS Ret	0	1	0	-	<b>Fire Light Control for Out Of Service Cars:</b> Enabling this parameter will turn off the fire light in the event the car cannot recall for being out of service. It could be in Earthquake, low oil, stall, etc.
Flash CB Light	0	1	0	-	<b>Flash Code Blue Light.</b> When set to 1 the code blue light inside the car station will flash.

Field Variable	Min	Max	Initial	Units	Description
<b>Table 7-7: Emergency Services</b>					
Hall Fire Light	0	4	0	-	<b>Hall Fire Light.</b> This variable controls the FLH output on the controller so it can be used for a hall fire light or a fire security override. The default operation is that FLH turns on while the car is on phase 1 or phase 2 fire service. +1 = On while phase 1 is in effect +2 = Flash FLH at 1 second intervals while activated +4 = FLH follows the Fire Light (FL) logic.
Hoistw Fire Ret	0	1	0	-	<b>Hoistway Fire Sensor Return Floor Selection.</b> 0 = Return to the Main fire floor 1 = Return to the Alternate fire floor.
HSV Door Cl CC	0	1	0	-	<b>Hospital Service Close door Car Call.</b> Close the doors from a car call when the car is on Hospital Service.
HWS 2 Fire Loc	0	1	50	-	<b>Fire Service Hoistway HWS2 Sensor Location</b> 0 = Same HW 1 = Separate hoistway
HWS 2 Fire Ret	0	1	0	-	<b>Second Hoistway Fire Service Sensor Return Option.</b> 0 = Main recall floor 1 = Alternate recall floor.
MachRm Fire Ret	0	1	0	-	<b>Machine Room Fire Sensor Return Floor Selection.</b> 0 = Return to the Main fire floor 1 = Return to the Alternate fire floor.
Med CCS Ovrride	0	1	0	-	<b>Medical Service Override Car Call Security.</b> When set to 1, medical service car will override car call security.
Med Door Reopen	0	2	0	-	<b>Medical Service Door Reopen.</b> When car is in Medical Service, this parameter determines the door open sequence for re-open: 0 = Stop 1 = Constant pressure 2 = Momentary to DOL
Med Em Floor	Bottom Floor	Top Floor	1	floor	<b>Medical Emergency Return Floor.</b>

Field Variable	Min	Max	Initial	Units	Description
<b>Table 7-7: Emergency Services</b>					
Med Em Sw Loc	0	1	0	-	<b>Medical Emergency Switch Location.</b> Selects the switch location for the front or rear door.
Med Ind Override	0	2	0	-	<b>Medical Service Overrides Independent Control:</b> 0 = Immediate 1 = After Delay 2 = No override
Rcl from F1 Alt	0	1	0	-	<b>Recall From Fire Phase 1 Alternate Floor.</b> 0 = If the car has returned to the alternate floor from a smoke sensor and when two fire hall switch are used, both must be on to recall the car from the alternate floor to the main floor. 1 = The car will recall from the alternate floor to the main floor from either hall fire key switch.  (Set to 1 for Massachusetts fire service).
Recall Reset	0	3	0	-	<b>Recall Reset Selection.</b> 0 = Reset fire service phase 1 after hall switch cycled through reset and turned off and car returns to fire floor. 1 = Reset phase 1 immediately after hall switch is cycled through reset and then turned off. 2 = Reset fire service without cycling fire switch through reset but turned off only if the smoke sensors were not activated.
Recall Reset 2	0	1	0	-	<b>Recall Reset Selection 2:</b> 0 = Reset fire service phase 1 with car at any floor. 1 = Reset phase 1 only if car at fire recall floor.



7.1.8 Group Dispatch Submenu

Field Variable	Min	Max	Initial	Units	Description
<b>Table 7-8: Group Dispatch</b>					
Alt Lobby Floor	1	Top Floor	1	floor	<b>Alternate Lobby Floor.</b> Galaxy groups could be configured to have an alternate lobby. Switching between regular lobby and alternate lobby could be done by means of LiftNet, Galileo, controller input or service timer. Once the alternate lobby is enabled, controllers will use this landing as the lobby floor for all dispatching purposes.
Alt Parking Fl	1	Top Floor	1	floor	<b>Alternate Parking Floor.</b> Normally, during parking operation, one elevator is always parked at the lobby. With alternate parking floor operation, a free car is parked at the alternate parking floor instead of the lobby floor. This operation is controlled by an input or from a service timer.
Asgn Park Fl DO	0	1	0	-	<b>Assign Parking Floor with Door Open.</b> By default we only park cars that have the doors closed after a time delay. this parameters allows to re-assign parking to cars with doors open as long as they do not have a direction to run.
Auto SVC tm-out	0	1	0	-	<b>Auto Service Time-out.</b> 0 = Disable 1 = Enable When this parameter is enabled and 'Auto SVC tot TM' (below) parameter time is set accordingly, each car is checked for answering assigned hall calls. If the car does not move to answer calls in the required time, it is put into AST service.  Hall calls that are assigned to that car are reassigned to working cars in the group. The group then periodically assigns hall calls to the AST car to verify if it can be put back into the group for normal operation.
Auto SVC tot TM	10	3200	120	sec	<b>Auto Service Time Out Time.</b> This time in seconds is used in conjunction with 'Auto SVC tm-out' (above) and is the amount of time that the group will wait before setting a 'not moving/responding' car as timed out.
Dis Opp HC Time	10	30	10	sec	<b>Disable Opposite Hall Call Time:</b> Specify amount of time the opposite hall call will be disabled.

Field Variable	Min	Max	Initial	Units	Description
<b>Table 7-8: Group Dispatch</b>					
Disable Opp HC	0	15	0	-	<b>Disable Opposite Hall Call</b> after initial hall call is entered: When the first up or down hall call is hit, disable opposite call for the time set; +1 = Front hc riser+2 = Rear hc riser+4 = IR front hc riser+8 = IR rear hc riser
Dn Peak Contrl	0	1	0	-	<b>Down Peak Control</b> 0 = Normal down peak 1 = Heavy down peak
Dn Pk Trig Cnt	1	100	12	count	<b>Down Peak Trigger Count.</b> Number of down hall calls above the lobby that are set within the down peak trigger time to place the system on down peak operation.
Dn Pk Trig Time	0	3200	60	sec	<b>Down Peak Trigger Time.</b> The time interval to count the number of down hall calls above the lobby to activate down peak operation.
Down Peak Pool	0	Number Cars	0	car	<b>Down Peak Pool.</b> Number of cars to be utilized for down peak.
Down Peak Time	0	3200	180	sec	<b>Down Peak Duration Time.</b> The duration time for down peak operation once down peak is activated.
ETA Co CC Time	0	60	15	sec	<b>ETA Coincident Car Call Time.</b> Hall calls will be assigned to the car with the coincident car call unless the car without the coincident car call can reach the call faster than ETA Coincident Car Call Time.
ETA Min Time	0	60	6	sec	<b>ETA Minimum Time.</b> For a hall call to be assigned to a new car, the difference in ETA must be greater than the ETA Minimum Time.
Grp Timer Park	0	Number Cars	0	car	<b>Group Service Timer Park Cars.</b> This is the number of parking cars when parking is set from the Service Activation Timer for Group parking.

Field Variable	Min	Max	Initial	Units	Description
<b>Table 7-8: Group Dispatch</b>					
High Priority FL	0	Top Floor	0	floor	<b>High Priority Floor.</b> When this parameter is set to a floor number other than zero the high priority operation is activated. If there is a call latched at the high priority floor and the timer set from the ' <b>High Priority TM</b> ' (below) expires, the group will choose the best car by considering only car calls. It will remove all hall calls on that best car except for the priority floor hall call. The car will serve all car calls and then service the priority floor before being assigned another hall call from the group..
High Priority TM	6	254	60	sec	<b>High Priority Time.</b> Works in conjunction with parameter ' <b>High Priority Floor</b> ' (above), it is the amount of time to wait before removing hall calls assigned to the selected best car.
Lobby Floor	Bottom Floor	Top Floor	1	floor	<b>Lobby Floor.</b>
Lobby Req Cntrl	0	1	0	-	<b>Lobby Request Control.</b> If the lobby request variable is set to non-zero, then that is how many cars are requested to the lobby all the time. When this flag is set to 1, the lobby request is only used when next up is active. Next Up can be active all the time, from a dedicated input or from Up Peak.
Lobby Request	0	Number Cars	0	car	<b>Lobby Request.</b> Number of Cars Requested to the Lobby floor. Used with Next Car Up operation.
Next Car Up	0	7	0	-	<b>Next Car Up.</b> Set to 1 or 2 will activate the Next Car Up operation. +1 = The next up car will open its door at the lobby and keep it open. The car is allowed to leave the floor after the Lobby Dwell time expires but will remain at the floor with the door open until an onward call is assigned to it. +2 = The next up car will close its door after the Lobby Dwell time expires and go off of next up but will remain at the lobby. An up hall call at the lobby will cause the car to open its door and go on next up. +4 = Next up is activated on Up Peak detection only. Next up can also be activated from an input.

Field Variable	Min	Max	Initial	Units	Description
<b>Table 7-8: Group Dispatch</b>					
Park Delay Time	0	120	8	sec	<b>Parking Delay Time.</b> Time delay an idle car waits before being parked.
Parking	0	Number Cars	1	car	<b>Number of Cars to Park.</b> One car is parked at the lobby. The remaining cars are parked at the most used floors of the building. If set to zero, no cars are parked.
Parking floor 1	0	Top Floor	0	floor	<b>Parking Floor 1.</b> Floor to park the <b>second</b> idle car. If set to zero, the group will use number of hall call history to decide where to park the car. The parking variable must be set to at least 1 for this function to work. See also Parking Type.
Parking floor 2	0	Top Floor	0	floor	<b>Parking Floor 2.</b> Floor to park the <b>third</b> idle car. If set to zero, the group will use number of hall call history to decide where to park the car. The parking variable must be set to at least 1 for this function to work. See also Parking Type.
Parking floor 3	0	Top Floor	0	floor	<b>Parking Floor 3.</b> Floor to park the <b>fourth</b> idle car. If set to zero, the group will use number of hall call history to decide where to park the car. The parking variable must be set to at least 1 for this function to work. See also Parking Type.
Parking floor 4	0	Top Floor	0	floor	<b>Parking Floor 4.</b> Floor to park the <b>fifth</b> idle car. If set to zero, the group will use number of hall call history to decide where to park the car. The parking variable must be set to at least 1 for this function to work. See also Parking Type.
Parking floor 5	0	Top Floor	0	floor	<b>Parking Floor 5.</b> Floor to park the <b>sixth</b> idle car. If set to zero, the group will use number of hall call history to decide where to park the car. The parking variable must be set to at least 1 for this function to work. See also Parking Type.

Field Variable	Min	Max	Initial	Units	Description
<b>Table 7-8: Group Dispatch</b>					
Parking floor 6	0	Top Floor	0	floor	<b>Parking Floor 6.</b> Floor to park the <b>seventh</b> idle car. If set to zero, the group will use number of hall call history to decide where to park the car. The parking variable must be set to at least 1 for this function to work. See also Parking Type.
Parking floor 7	0	Top Floor	0	floor	<b>Parking Floor 7.</b> Floor to park the <b>eighth</b> idle car. If set to zero, the group will use number of hall call history to decide where to park the car. The parking variable must be set to at least 1 for this function to work. See also Parking Type.
Parking Type	0	3	0	-	<b>Parking Type.</b> Determines the type of parking operation that is implemented by the group. 0 = Park free cars to floors with the most hall calls for that 15 minute period. 1 = Divide the hoistway by the number of cars and place a car in each zone starting with the lobby. 2 = Park cars according to the adjustable variable parking floor.  Note that during parking, a car is always parked at the Lobby except when the option for alternate parking floor is selected through an input.
Parking Width	0	Top Floor	0	floor	<b>Parking Width.</b> The number of floor that a car is within to be considered parked at the parking floor. See also Parking Type.
Up Peak Contrl	0	1	0	-	<b>Up Peak Control.</b> 0 = Normal up peak 1 = Heavy up peak
Up Peak Pool	0	Number Cars	1	car	<b>Up Peak Pool.</b> Number of cars to be utilized for up peak.
Up Peak Time	0	3200	180	sec	<b>Up Peak Duration Time.</b> The duration time for up peak operation once up peak is activated. If set to zero, up peak operation will never turn on.

Field Variable	Min	Max	Initial	Units	Description
<b>Table 7-8: Group Dispatch</b>					
Up Pk CC Count	1	40	3	count	<b>Up Peak Car Call Count.</b> Number of car calls the car must have when leaving the lobby to count as an up peak trigger.
Up Pk Trig Cnt	1	100	3	count	<b>Up Peak Trigger Count.</b> The number of up peak triggers that are set within the up peak trigger time to activate up peak operation. Up peak triggers are counted when the car leaves the lobby with the load dispatch input set or with the more car calls than the up peak car call count.
Up Pk Trig Time	0	3200	60	sec	<b>Up Peak Trigger Time.</b> The time interval to count the number of up peak triggers.

7.1.9 Group Options Submenu

Field Variable	Min	Max	Initial	Units	Description
<b>Table 7-9: Group Options</b>					
1st EP Run Car	0	Number Cars	1	car	<b>First Emergency Power Run Car.</b> This is the first car selected to run. If this car cannot run, the next consecutive car is selected.
1st Rcl EPSF 2	0	Number Cars	2	car	<b>First Return Car Emergency Power Service Feeder 2.</b> This will be the first car recalled in Emergency Power (the rest are done sequentially in a loop) for power feeder 2
1st Recall Car	0	Number Cars	1	car	<b>First Recall Car.</b> This is the first car allowed to recall during the emergency power recall sequence. The recall sequence continues in consecutive order and then loops around until all cars are recalled.
1st Run EPSF 2	0	Number Cars	2	car	<b>First Run Car Emergency Power Service Feeder 2.</b> This will be the first car selected to run on emergency power (the rest are done sequentially in a loop) for power feeder 2
2nd IR Car	0	Number Cars	0	car	<b>2nd Inconspicuous Riser Car.</b> Set this option to have a second car answer the Inconspicuous Risers.

Field Variable	Min	Max	Initial	Units	Description
<b>Table 7-9: Group Options</b>					
ATT Pref Time	0	60	0	sec	<b>Attendant ETA Preference Time.</b> When set to non-zero, the car not on attendant service has this time added to its ETA time. This causes the attendant car to be given a preference for the hall call.
CB Button Loc	0	2	0	-	<b>Code Blue Location:</b> 0 = CB on CB 1 = CB on HCB 2 = CB on IR
CB IR Penalty	0	60	10	sec	<b>IR Car Code Blue Penalty Time.</b> This is used to calculate and give preference to cars in fully automatic operation
CB Rcll Any Car	0	1	0	-	<b>Code Blue Recall Any Call.</b> 0 = Disable 1 = Enables dispatcher to recall any car if Code Blue Cars 1 and 2 are not available.  If you want to select any car as your primary option, make <b>Code Blue Car</b> and <b>Code Blue Car #2</b> equal to zero and enable this setting.
CB Req Ind Car	0	1	0	-	<b>Code Blue Request Independent Car.</b> Code blue request for car on independent operation. Set to 1 in dispatcher, and in all cars so the car could be requested (flash EML) if the car is in independent mode.
CB Sel IR Car	0	1	0	-	<b>Code Blue Over IR Car</b>
CB SRiser Car	0	Number Cars	0	car	<b>Code Blue Second Riser Car Select</b>
CBlue Over Hugs	0	1	0	-	<b>Code Blue Override HUGS Operation.</b> Turns on option to have code blue operation override hugs operation. 0 = No override 1 = Override

Field Variable	Min	Max	Initial	Units	Description
<b>Table 7-9: Group Options</b>					
Code Blue Car	0	Number Cars	0	car	<b>Code Blue Car.</b> When a code blue call is initiated, this will be the first car to be sent to respond. If car is not available, see variables ' <b>Code Blue Car#2</b> ' and ' <b>CB Rcll Any Car</b> ' for more options.
Code Blue Car#2	0	Number Cars	0	car	<b>Code Blue Car #2.</b> When a code blue call is initiated, this will be the car to be sent to respond in the event that first ' <b>Code Blue Car</b> ' is not available, see variables ' <b>Code Blue Car</b> ' and ' <b>CB Rcll Any Car</b> ' for more options.
Dispatcher Car	0	Number Cars	0	car	<b>Dispatcher Car.</b> If set to 1, this car is allowed to become the dispatcher. <b>In normal operation, this variable would be set to zero and car #1 would be the dispatcher.</b> If car #1 is shut down, car #2 automatically becomes the dispatcher. During installation, it may be necessary to force car #3 (set <b>Dispatcher Car</b> to 3) or above to be the dispatcher until car #1 or #2 are brought on line.
Em Power Cars	1	Number Cars	1	car	<b>Number of Emergency Power Cars</b> that can run at the same time on the emergency power source.
Emerg Dispatch	0	7	0	-	<b>Emergency Dispatch.</b> This parameter is applied to both the car that is selected as the dispatcher and also the non-dispatcher cars. If set to 1 and hall call power lost, the dispatcher car will set down hall calls above the lobby and up hall call at and below the lobby. For the non-dispatcher cars, if set to a 1, and communications is lost to the dispatcher car, the car will dispatch itself to down hall calls above the lobby and up hall calls below the lobby. The front hall call and rear hall call bits settings are only used for the dispatcher car and when set, if communication is lost to a particular hall call board, hall calls are set for the affected floors.
EMP ATT car 1st	0	1	0	-	<b>Emergency Power Attendant Car First.</b> Select and Prioritize the attendant car for running on emergency power service. It won't be recalled. After recall is complete for the group, it recovers and goes back in service



Field Variable	Min	Max	Initial	Units	Description
<b>Table 7-9: Group Options</b>					
EmPwr Op Output	0	3	0	-	<b>Emergency Power Operation LED.</b> This parameter controls the group outputs for emergency power status for each car. 0 = Outputs are on for cars that are operational. 1 = Outputs on for cars on normal power. 2 = Outputs on for car on emergency power. 3 = Outputs on for cars that are being recalled.
EmPwr Pk Output	0	2	0	-	<b>Emergency Power Park LED.</b> This parameter controls the group outputs for emergency power parked status for each car. 0 = Cars are parked on emergency power. 1 = Cars are parked or selected to run.
EP Man Op TimOt	60	180	120	sec	<b>Emergency Power Manual Operation Time-Out.</b> Time that designated attendant car does not run for emergency power operation to sequence next car to recall.
EP Man Sel En	0	3	1	-	<b>Emergency Power Manual Select Enable:</b> 0 = If set to zero, the recall sequence is aborted and any moving car will stop at the next floor to allow the selected car to run. +1 = Car is selected to run when the currently selected car completes its recall. +2 = Makes the selected car wait for all the cars to recall before being selected to run.
EP Rcl Out en	0	1	0	-	<b>Emergency Cars Finished Recalling Output Enable.</b> It enables an output in the hall call board for Emergency Power Complete (EPCOM). This setting is only read in power up so after changing this setting you need to reboot the controller.
EP Recall Delay	0	3200	15	sec	<b>Emergency Power Recall Delay Time.</b> Time delay before the group starts the emergency power recall sequence.
EP Recover Tim	1	60	20	sec	<b>Emergency Power Recovery Time.</b> When elevators are in Emergency Power recall, this is the time that the dispatcher will wait for each car to recover to a floor. If the car is in the middle of a blind shaft, you need to calculate the time each car may take to get to a floor in emergency power recovery speed.

Field Variable	Min	Max	Initial	Units	Description
<b>Table 7-9: Group Options</b>					
Grp CC Ovrride	0	1	0	-	<b>Group Car Call Override.</b> Normally visitor access allows the car call security to be overridden momentarily from a push button in an owners apartment. With this parameter set to 1, the security override works directly from a key switch input.
Grp CC Sec OvrT	1	240	60	sec	<b>Group Car Call Security Override Timer.</b> This is the amount of time that the car call security is overridden when a group car call security override button is pressed.
Handicap Wait	0	255	0	sec	<b>Handicap Car Wait Time.</b> Special operation that when a passenger presses a handicap hall button, the group adds this time to the ETA of all cars that do not have enough capacity. See Handicap Capacity in car options. Normally, if a car is at the floor of the handicap hall call, it will get the assignment regardless of the handicap capacity unless this value is set to 255.
HC Asg SecType	0	15	0	-	<b>Hall Call Assignment Security Type.</b> Use with Special Priority Service. Determines what hall calls should be given a special priority. Settings are: 1 = Up 2 = Down 4 = Up Rear 8 = Down Rear
HC Securty ctrl	0	2	0	-	<b>Hall Call Security Control.</b> Set what riser the hall call security inputs work with: 0 = Only standard hall calls 1 = Standard hall calls and Second Riser hall calls 2 = Only Second Riser hall calls

Field Variable	Min	Max	Initial	Units	Description
<b>Table 7-9: Group Options</b>					
HC X-Assign En	0	5	0	-	<p><b>Hall Call Cross Assignment Enable.</b> When set to:                      1 = Front hall call cross assignment is enabled                      2 = Hall calls cross cancellation is used and hall calls are not cancelled when all cars are out of service                      3 = <b>This value is not valid and may cause unpredictable results.</b>                      4 = Rear hall call cross assignment and                      5 = Front and rear hall call cross assignment. The group will look for cross assignment calls as well as hall calls.</p> <p><b>Power should be cycled on controller after this variable is modified so all communications to all devices are made.</b></p>
HC X-Assign ETA	0	500	60	sec	<p><b>Hall Call Cross Assignment ETA Limit.</b> If ETA for hall call assignment is greater than this ETA limit, the hall call will be cross-assigned to the old group controller.</p>
Invert HC Sec	0	1	0	-	<p><b>Invert Hall Call Security.</b> When set to 1, hall call security inputs are secured when the security input goes off from a normally closed switch. Normally, the security input must be on to secure the hall call.</p>
IR Car	0	Number Cars	0	car	<p><b>Inconspicuous Riser Car.</b> This car is assigned all the IR hall calls.</p>
IR Control	0	15	0	-	<p><b>Inconspicuous Riser Control.</b> This parameter alters how IR riser service is activated or deactivated.                      0 = IR active from ICR or RICR input                      +1 = IR activated when any IR call is activated                      +2 = Finish car calls then answer IR calls                      +4 = Finish car call before going off IR.                      +8 = 2nd IR Car selected if 1st IR Car Out of Service</p>
Number Vip Cars	0	Number Cars	1		<p><b>Number of VIP Cars.</b> Number of cars allow to service VIP (priority service) calls at one time.</p>
OTS No HC Canc	0	1	0	-	<p><b>Out of Service No Hall Call Cancelled.</b> Do not cancel hall calls if cars are out of service. This is used in accordance with cross assignment feature.</p>

Field Variable	Min	Max	Initial	Units	Description
<b>Table 7-9: Group Options</b>					
Recall Timeout	1	600	60	sec	<b>Recall Time-out.</b> The time allowed for the car to reach the recall floor during the emergency power recall sequence. If this timer expires, the next car is selected to recall.
Sabbath Restart	0	3200	8	sec	<b>Sabbath Restart Delay Time.</b> The amount of time after the elevator answered the last sabbath call to restart the process.
Secnd Risr Ctl	0	3	0	-	<b>Second Riser Control.</b> Defines the second riser operation. 0 = Car defined for second riser answers second riser call and standard hall calls. 1 = Car defined for second riser answer only second riser calls. 2 = Second riser call or'ed with standard riser calls if second riser operation not selected from input.
Single Auto PB	0	5	0	-	<b>Single Automatic Push Button Operation.</b> 0 = Manual Doors (this would be the normal operation for cars with manual doors). 1 = Enable SAPB operation for simplex car with automatic doors. 2 = Disable SAPB operation for cars with manual doors. 3 = Invalid setting. 4 = Allow only one car call to be entered at floor for cars with manual doors regardless of the door position. 5 = Allow only one car call to be entered at floor for cars with automatic doors.  This feature normally allows only hall calls and car calls to register when the doors are closed.
Skip Car@RcFLDO	0	1	0	-	<b>Skip Car at Recall Floor with Door Open.</b> While on Emergency Power Recall sequence: if enabled, out of service cars at the Emergency Power Recall floor with door open will be given a chance to run, 0 = Override immediately 1 = Override after time-delay. Time delay defined by variable 'EP Recover Tim'.

Field Variable	Min	Max	Initial	Units	Description
<b>Table 7-9: Group Options</b>					
SkipCarN@RcFLDO	0	1	0	-	<b>Skip Car Not at Recall Floor with Door Open.</b> While on Emergency Power Recall sequence: if enabled, out of service cars at the Emergency Power Recall floor with door open will be given a chance to run, 0 = Override immediately 1 = Override after time-delay. Time delay defined by variable 'EP Recover Tim'.
SR Swing HC Cnt	2	5	3	count	<b>Second Riser Swing HC Count.</b> The minimum number of Swing Riser hall calls required to swing second SR car out of group operation.
SR Swing HC Dif	1	5	3	count	<b>Second Riser Swing HC Difference.</b> The smallest difference of Swing Riser hall calls greater than Standard hall calls that will swing second SR car out of group operation to serve SR hall calls.
Third Riser Ctrl	0	1	0	-	<b>Third Riser Control.</b> Defines the third riser operation. 0 = Car defined for third riser answer third riser calls and standard hall calls. 1 = Car defined for third riser answer only third riser calls.
Vid Pos Car 1	1	Number Cars	1	car	<b>Video Position Car 1.</b> The column where the car is displayed on the dispatch screen starts from left to right for positions 1 through 6 (8 for high rise cars). Car 1 through 6 positions are defaulted to display positions 1 through 6 respectively. Changing the car's video position changes the column where the car is displayed.
Vid Pos Car 2	1	Number Cars	2	car	<b>Video Position Car 2.</b> See Video Position Car 1 for an explanation.
Vid Pos Car 3	1	Number Cars	3	car	<b>Video Position Car 3.</b> See Video Position Car 1 for an explanation.
Vid Pos Car 4	1	Number Cars	4	car	<b>Video Position Car 4.</b> See Video Position Car 1 for an explanation.

Field Variable	Min	Max	Initial	Units	Description
<b>Table 7-9: Group Options</b>					
Vid Pos Car 5	1	Number Cars	5	car	<b>Video Position Car 5.</b> See Video Position Car 1 for an explanation.
Vid Pos Car 6	1	Number Cars	6	car	<b>Video Position Car 6.</b> See Video Position Car 1 for an explanation.
Vid Pos Car 7	1	Number Cars	7	car	<b>Video Position Car 7.</b> See Video Position Car 1 for an explanation.
Vid Pos Car 8	1	Number Cars	8	car	<b>Video Position Car 8.</b> See Video Position Car 1 for an explanation.
Vip Button Loc	0	2	0	-	<b>VIP Button Location.</b> 0 = VIP on vip I/O board 1 = VIP on HCB I/O board 2 = VIP on IR I/O
VIP Operation	0	3	0	-	<b>VIP (Priority Call) Operation.</b> +1 = Cancel hall call if no cars available for VIP call. +2 = Cancel car call upon initiation of being selected as the VIP car. +4 = Cancel VIP HC with no door reopen
VIP Sel IR Car	0	1	0	-	<b>VIP Selection Over IR Car.</b> Enables VIP operation to select a car that is on IR service. +1 = Enables VIP operation to select a car that is on IR service. +2 = VIP selects only IR Car
X-Assign Cars	0	Number Cars	0	car	<b>Cross Assignment Cars.</b> Number of cars in the old group to assign calls using cross assignment system.

7.1.10 CC & COP Lights Submenu

Field Variable	Min	Max	Initial	Units	Description
<b>Table 7-10: CC &amp; COP Lights</b>					
Backlight Lt	0	63	0	color	<b>Enable Backlight Output Lights</b> for RGB style output lights in COP Bit0: Fire, Bit1: Medical, Bit2: Emergency, Bit3: OTS, Bit4: Att Up/Dn Light, Bit5: Non-CC
CC AttDn Blue	0	100	0	%	<b>Car Call Button Attendant Dn Light Blue Intensity</b>
CC AttDn Bright	0	100	100	%	<b>Car Call Button Attendant Dn Light Brightness</b>
CC AttDn Color	0	15	0	color	<b>Car Call Button Attendant Dn Light Color:</b> 0 Based on parameters 1 Red 2 Orange 3 Yellow 4 Chartreuse 5 Green 6 Aquamarine 7 Cyan 8 Azure 9 Blue 10 Violet 11 Magenta 12 Rose 13 Rose White 14 Warm White 15 Cool White
CC AttDn Green	0	100	0	%	<b>Car Call Button Attendant Dn Light Green Intensity</b>
CC AttDn Red	0	100	100	%	<b>Car Call Button Attendant Dn Light Red Intensity</b>
CC AttUp Blue	0	100	0	%	<b>Car Call Button Attendant Up Light Blue Intensity</b>
CC AttUp Bright	0	100	100	%	<b>Car Call Button Attendant Up Light Brightness</b>

Field Variable	Min	Max	Initial	Units	Description
<b>Table 7-10: CC &amp; COP Lights</b>					
CC AttUp Color	0	15	0	color	<b>Car Call Button Attendant Up Light Color:</b> 0 Based on parameters 1 Red 2 Orange 3 Yellow 4 Chartreuse 5 Green 6 Aquamarine 7 Cyan 8 Azure 9 Blue 10 Violet 11 Magenta 12 Rose 13 Rose White 14 Warm White 15 Cool White
CC AttUp Green	0	100	100	%	<b>Car Call Button Attendant Up Light Green Intensity</b>
CC AttUp Red	0	100	0	%	<b>Car Call Button Attendant Up Light Red Intensity</b>
CC Light Ctl	0	3	0		<b>Flashing Car Call Lights</b> options. +1 = Flash Car Call Security +2= Flash Attendant Annunciator Sequence
CC Off Blue	0	100	50	%	<b>Car Call Off Blue Intensity</b>
CC Off Bright	0	100	20	%	<b>Car Call Output Off Brightness for LED</b>



Field Variable	Min	Max	Initial	Units	Description
<b>Table 7-10: CC &amp; COP Lights</b>					
CC Off Color	0	15	15	color	<b>Car Call Button Light Off Color</b> 0 Based on RGB intensity parameters 1 Red 2 Orange 3 Yellow 4 Chartreuse 5 Green 6 Aquamarine 7 Cyan 8 Azure 9 Blue 10 Violet 11 Magenta 12 Rose 13 Rose White 14 Warm White 15 Cool White
CC Off Green	0	100	100	%	<b>Car Call Off Green Intensity</b>
CC Off Red	0	100	62.5	%	<b>Car Call Off Red Intensity</b>
CC On Blue	0	100	50	%	<b>Car Call On Blue Intensity</b>
CC On Bright	0	100	100	%	<b>Car Call Output On Brightness for LED</b>

Field Variable	Min	Max	Initial	Units	Description
<b>Table 7-10: CC &amp; COP Lights</b>					
CC On Color	0	15	15	color	<b>Car Call Button Light On Color</b> 0 Based on RGB intensity parameters 1 Red 2 Orange 3 Yellow 4 Chartreuse 5 Green 6 Aquamarine 7 Cyan 8 Azure 9 Blue 10 Violet 11 Magenta 12 Rose 13 Rose White 14 Warm White 15 Cool White
CC On Green	0	100	100	%	<b>Car Call On Green Intensity</b>
CC On Red	0	100	62.5	%	<b>Car Call On Red Intensity</b>
CC Sec Blue	0	100	100	%	<b>Car Call Security Light Blue Intensity</b>
CC Sec Bright	0	100	100	%	<b>Car Call Security Light Brightness</b>

Field Variable	Min	Max	Initial	Units	Description
<b>Table 7-10: CC &amp; COP Lights</b>					
CC Sec Color	0	15	15	color	<b>Car Call Button Security Color</b> 0 Based on RGB intensity parameters 1 Red 2 Orange 3 Yellow 4 Chartreuse 5 Green 6 Aquamarine 7 Cyan 8 Azure 9 Blue 10 Violet 11 Magenta 12 Rose 13 Rose White 14 Warm White 15 Cool White
CC Sec Green	0	100	0	%	<b>Car Call Security Light Green intensity</b>
CC Sec Red	0	100	100	%	<b>Car Call Security Light Red Intensity</b>
Emer Lt Blue	0	100	0	%	<b>Emergency Light Blue Intensity</b>
Emer Lt Bright	0	100	100	%	<b>Emergency Light Brightness</b>

Field Variable	Min	Max	Initial	Units	Description
<b>Table 7-10: CC &amp; COP Lights</b>					
Emer Lt Color	0	15	0	color	<b>Emergency Light Color</b> 0 Based on parameters 1 Red 2 Orange 3 Yellow 4 Chartreuse 5 Green 6 Aquamarine 7 Cyan 8 Azure 9 Blue 10 Violet 11 Magenta 12 Rose 13 Rose White 14 Warm White 15 Cool White
Emer Lt Green	0	100	100	%	<b>Emergency Light Green Intensity</b>
Emer Lt Red	0	100	75	%	<b>Emergency Light Red Intensity</b>
Fire Lt Blue	0	100	50	%	<b>Fire Light Blue Intensity</b>
Fire Lt Bright	0	100	100	%	<b>Fire light Brightness</b>

Field Variable	Min	Max	Initial	Units	Description
<b>Table 7-10: CC &amp; COP Lights</b>					
Fire Lt Color	0	15	0	color	<b>Fire Light Color:</b> 0 Based on parameters 1 Red 2 Orange 3 Yellow 4 Chartreuse 5 Green 6 Aquamarine 7 Cyan 8 Azure 9 Blue 10 Violet 11 Magenta 12 Rose 13 Rose White 14 Warm White 15 Cool White
Fire Lt Green	0	100	100	%	<b>Fire Light Green Intensity</b>
Fire Lt Red	0	100	62.5	%	<b>Fire Light Red Intensity</b>
Med Lt Blue	0	100	100	%	<b>Medical Light Blue Intensity</b>
Med Lt Bright	0	100	100	%	<b>Medical Light Brightness</b>

Field Variable	Min	Max	Initial	Units	Description
<b>Table 7-10: CC &amp; COP Lights</b>					
Med Lt Color	0	15	0	color	<b>Medical Light Color:</b> 0 Based on parameters 1 Red 2 Orange 3 Yellow 4 Chartreuse 5 Green 6 Aquamarine 7 Cyan 8 Azure 9 Blue 10 Violet 11 Magenta 12 Rose 13 Rose White 14 Warm White 15 Cool White
Med Lt Green	0	100	0	%	<b>Medical Light Green Intensity</b>
Med Lt Red	0	100	0	%	<b>Medical Light Red Intensity</b>
OTS Lt Blue	0	100	0	%	<b>Out of Service Light Blue Intensity</b>
OTS Lt Bright	0	100	100	%	<b>Out of Service Light Brightness</b>

Field Variable	Min	Max	Initial	Units	Description
<b>Table 7-10: CC &amp; COP Lights</b>					
OTS Lt Color	0	15	0	color	<b>Out of Service Light Color</b> 0 Based on parameters 1 Red 2 Orange 3 Yellow 4 Chartreuse 5 Green 6 Aquamarine 7 Cyan 8 Azure 9 Blue 10 Violet 11 Magenta 12 Rose 13 Rose White 14 Warm White 15 Cool White
OTS Lt Green	0	100	40	%	<b>Out of Service Light Green Intensity</b>
OTS Lt Red	0	100	100	%	<b>Out of Service light red intensity</b>

7.1.11 HC & IR Call Lights Submenu

Field Variable	Min	Max	Initial	Units	Description
<b>Table 7-11: HC &amp; IR Call Lights</b>					
HC Off Bright	0	100	20	%	<b>Hall Call Light Off Brightness.</b> Select the brightness for LED hall call button when button is NOT pressed. Used only with GAL serial hall button fixtures.
HC On Bright	0	100	100	%	<b>Hall Call Light On Brightness for LED Hall Call Buttons.</b> Used only with GAL serial hall button fixtures.
HCDn Off Blue	0	100	50	%	<b>Hall Call Light Off Blue Intensity.</b> Used only with GAL serial hall button fixtures.
HCDn Off Bright	0	100	20	%	<b>Hall Call Light Off Brightness for LED Hall Call Buttons.</b> Used only with GAL serial hall button fixtures.

Field Variable	Min	Max	Initial	Units	Description
<b>Table 7-11: HC &amp; IR Call Lights</b>					
HCDn Off Color	0	15	15	color	<p><b>Hall Down Call Off Color.</b>                      Select what color LED to illuminate on hall call button when button is NOT pressed. Used only with GAL serial hall button fixtures.                      0 Based on parameters                      1 Red                      2 Orange                      3 Yellow                      4 Chartreuse                      5 Green                      6 Aquamarine                      7 Cyan                      8 Azure                      9 Blue                      10 Violet                      11 Magenta                      12 Rose                      13 Rose White                      14 Warm White                      15 Cool White</p>
HCDn Off Green	0	100	100	%	<p><b>Hall Call Light Off Green Intensity.</b> Used only with GAL serial hall button fixtures.</p>
HCDn Off Red	0	100	62.5	%	<p><b>Hall Call Light Off Red Intensity.</b> Used only with GAL serial hall button fixtures.</p>
HCDn On Blue	0	100	50	%	<p><b>Hall Call Light On Blue Intensity.</b> Used only with GAL serial hall button fixtures.</p>
HCDn On Bright	0	100	100	%	<p><b>Hall Call Light On Brightness for LED Hall Call Buttons.</b> Used only with GAL serial hall button fixtures.</p>



Field Variable	Min	Max	Initial	Units	Description
<b>Table 7-11: HC &amp; IR Call Lights</b>					
HCDn On Color	0	15	15	color	<p><b>Hall Call Down On Light Color.</b> Select what color LED to illuminate on hall call button when button is pressed. Used only with GAL serial hall button fixtures.</p> <p>0 Based on parameters                      1 Red                      2 Orange                      3 Yellow                      4 Chartreuse                      5 Green                      6 Aquamarine                      7 Cyan                      8 Azure                      9 Blue                      10 Violet                      11 Magenta                      12 Rose                      13 Rose White                      14 Warm White                      15 Cool White</p>
HCDn On Green	0	100	100	%	<p><b>Hall Call Light On Green Intensity.</b> Used only with GAL serial hall button fixtures.</p>
HCDn On Red	0	100	62.5	%	<p><b>Hall Call Light On Red Intensity.</b> Used only with GAL serial hall button fixtures.</p>
HCUp Off Blue	0	100	50	%	<p><b>Hall Call Up Light Off Blue Intensity.</b></p>
HCUp Off Brght	0	100	20	%	<p><b>Hall Call Output Off Brightness for LED</b> (higher number is brighter)</p>

Field Variable	Min	Max	Initial	Units	Description
<b>Table 7-11: HC &amp; IR Call Lights</b>					
HCUp Off Color	0	15	15		<b>Hall Call Button Up Light Off Color</b> 0 Based on RGB intensity parameters 1 Red 2 Orange 3 Yellow 4 Chartreuse 5 Green 6 Aquamarine 7 Cyan 8 Azure 9 Blue 10 Violet 11 Magenta 12 Rose 13 Rose White 14 Warm White 15 Cool White
HCUp Off Green	0	100	100	%	<b>Hall Call Up Light Off Green Intensity</b>
HCUp Off Red	0	100	62.5	%	<b>Hall Call Up Light Off Red Intensity</b>
HCUp On Blue	0	100	50	%	<b>Hall Call UP Light On Blue Intensity</b>
HCUp On Bright	0	100	0	%	<b>Hall Call Output Up On Brightness for LED</b> (higher number is brighter)

Field Variable	Min	Max	Initial	Units	Description
<b>Table 7-11: HC &amp; IR Call Lights</b>					
HCUp On Color	0	15	15	color	<b>Hall Call Button Up Light On Color</b> 0 Based on RGB intensity parameters 1 Red 2 Orange 3 Yellow 4 Chartreuse 5 Green 6 Aquamarine 7 Cyan 8 Azure 9 Blue 10 Violet 11 Magenta 12 Rose 13 Rose White 14 Warm White 15 Cool White
HCUp On Green	0	100	100	%	<b>Hall Call Up Light On Green Intensity</b>
HCUp On Red	0	100	62.5	%	<b>Hall Call Up Light On Red Intensity</b>
IR Color Ctrl	0	1	0	-	<b>IR light color control:</b> 0 = IR Color 1 = HC Color until IR activated
IRDn Off Blue	0	100	50	%	<b>Hall Call IR Dn Light Off Blue Intensity</b>
IRDn Off Brght	0	100	20	%	<b>Hall Call IR Dn Light Off Brightness</b>

Field Variable	Min	Max	Initial	Units	Description
<b>Table 7-11: HC &amp; IR Call Lights</b>					
IRDn Off Color	0	15	15	color	<b>Hall Call IR Dn Light Off Color</b> 0 Based on parameters 1 Red 2 Orange 3 Yellow 4 Chartreuse 5 Green 6 Aquamarine 7 Cyan 8 Azure 9 Blue 10 Violet 11 Magenta 12 Rose 13 Rose White 14 Warm White 15 Cool White
IRDn Off Green	0	100	100	%	<b>Hall Call IR Dn Light Off Green Intensity</b>
IRDn Off Red	0	100	62.5	%	<b>Hall Call IR Dn Light Off Red Intensity</b>
IRDn On Blue	0	100	50	%	<b>Hall Call IR Dn Light On Blue Intensity</b>
IRDn On Bright	0	100	20	%	<b>Hall Call IR Dn Light On Brightness</b>

Field Variable	Min	Max	Initial	Units	Description
<b>Table 7-11: HC &amp; IR Call Lights</b>					
IRDn On Color	0	15	15	color	<b>Hall Call IR Dn Light On Color</b> 0 Based on parameters 1 Red 2 Orange 3 Yellow 4 Chartreuse 5 Green 6 Aquamarine 7 Cyan 8 Azure 9 Blue 10 Violet 11 Magenta 12 Rose 13 Rose White 14 Warm White 15 Cool White
IRDn On Green	0	100	100	%	<b>Hall Call IR Dn Light On Green Intensity</b>
IRDn On Red	0	100	62.5	%	<b>Hall Call IR Dn Light On Red Intensity</b>
IRUp Off Blue	0	100	50	%	<b>Hall Call IR Up Light Off Blue Intensity</b>
IRUp Off Brght	0	100	100	%	<b>Hall Call IR Up Light Off Brightness</b>

Field Variable	Min	Max	Initial	Units	Description
<b>Table 7-11: HC &amp; IR Call Lights</b>					
IRUp Off Color	0	15	15	color	<b>Hall Call IR Up Light Off Color</b> 0 Based on parameters 1 Red 2 Orange 3 Yellow 4 Chartreuse 5 Green 6 Aquamarine 7 Cyan 8 Azure 9 Blue 10 Violet 11 Magenta 12 Rose 13 Rose White 14 Warm White 15 Cool White
IRUp Off Green	0	100	100	%	<b>Hall Call IR Up Light Off Green Intensity</b>
IRUp Off Red	0	100	62.5	%	<b>Hall Call IR Up Light Off Red Intensity</b>
IRUp On Blue	0	100	50	%	<b>Hall Call IR Up On Blue Intensity</b>
IRUp On Bright	0	100	100	%	<b>Hall Call IR Up On Brightness</b>

Field Variable	Min	Max	Initial	Units	Description
<b>Table 7-11: HC &amp; IR Call Lights</b>					
IRUp On Color	0	15	15	color	<b>Hall Call IR Up On Color</b> 0 Based on parameters 1 Red 2 Orange 3 Yellow 4 Chartreuse 5 Green 6 Aquamarine 7 Cyan 8 Azure 9 Blue 10 Violet 11 Magenta 12 Rose 13 Rose White 14 Warm White 15 Cool White
IRUp On Green	0	100	100	%	<b>Hall Call IR Up On Green Intensity</b>
IRUp On Red	0	100	62.5	%	<b>Hall Call IR Up On Red Intensity</b>

7.1.12 CB, VIP HSec Hall Lights Submenu

Field Variable	Min	Max	Initial	Units	Description
<b>Table 7-12: CB, VIP HSec Call Lights</b>					
CB Off Blue	0	100	100	%	<b>Hall Call CB Light Off Blue Intensity</b>
CB Off Bright	0	100	20	%	<b>Hall Call CB Light Off Brightness</b>

Field Variable	Min	Max	Initial	Units	Description
<b>Table 7-12: CB, VIP HSec Call Lights</b>					
CB Off Color	0	15	0	color	<b>Hall Call CB Light Off Color</b> 0 Based on parameters 1 Red 2 Orange 3 Yellow 4 Chartreuse 5 Green 6 Aquamarine 7 Cyan 8 Azure 9 Blue 10 Violet 11 Magenta 12 Rose 13 Rose White 14 Warm White 15 Cool White
CB Off Green	0	100	0	%	<b>Hall Call CB Light Off Green Intensity</b>
CB Off Red	0	100	0	%	<b>Hall Call CB Light Off Red Intensity</b>
CB On Blue	0	100	100	%	<b>Hall Call CB Light On Blue Intensity</b>
CB On Bright	0	100	100	%	<b>Hall Call CB Light On Brightness</b>



Field Variable	Min	Max	Initial	Units	Description
<b>Table 7-12: CB, VIP HSec Call Lights</b>					
CB On Color	0	15	0	color	<b>Hall Call CB Light On Color:</b> 0 Based on parameters 1 Red 2 Orange 3 Yellow 4 Chartreuse 5 Green 6 Aquamarine 7 Cyan 8 Azure 9 Blue 10 Violet 11 Magenta 12 Rose 13 Rose White 14 Warm White 15 Cool White
CB On Green	0	100	0	%	<b>Hall Call CB Light On Green Intensity</b>
CB On Red	0	100	0	%	<b>Hall Call CB Light On Red Intensity</b>
HC Sec Blue	0	100	100	%	<b>Hall Call Light Blue Intensity When on Security.</b> Used only with GAL serial hall button fixtures.
HC Sec Bright	0	100	100	%	<b>Hall Call Security Brightness for Secured Floors</b>

Field Variable	Min	Max	Initial	Units	Description
<b>Table 7-12: CB, VIP HSec Call Lights</b>					
HC Sec Color	0	15	15	color	<p><b>Hall Call Security Color</b> to illuminate the hall buttons when the system is on security. Used only with GAL serial hall button fixtures.</p> <p>0 Based on parameters                      1 Red                      2 Orange                      3 Yellow                      4 Chartreuse                      5 Green                      6 Aquamarine                      7 Cyan                      8 Azure                      9 Blue                      10 Violet                      11 Magenta                      12 Rose                      13 Rose White                      14 Warm White                      15 Cool White</p>
HC Sec Ctl	0	7	0	-	<p><b>Hall Call Button Security Light.</b>                      +1 = Invert security                      +2 = Flash security                      +4 = Master Security Enabled</p>
HC Sec Green	0	100	0	%	<p><b>Hall Call Light Green Intensity When on Security.</b>                      Used only with GAL serial hall button fixtures.</p>
HC Sec Red	0	100	100	%	<p><b>Hall Call Light Red Intensity When on Security.</b> Used only with GAL serial hall button fixtures.</p>
Vip Off Blue	0	100	0	%	<p><b>Hall Call Vip Light Off Blue Intensity</b></p>
Vip Off Bright	0	100	20	%	<p><b>Hall Call Vip Light Off Brightness</b></p>

Field Variable	Min	Max	Initial	Units	Description
<b>Table 7-12: CB, VIP HSec Call Lights</b>					
Vip Off Color	0	15	0	color	<b>Hall Call Vip Light Off Color</b> 0 Based on parameters 1 Red 2 Orange 3 Yellow 4 Chartreuse 5 Green 6 Aquamarine 7 Cyan 8 Azure 9 Blue 10 Violet 11 Magenta 12 Rose 13 Rose White 14 Warm White 15 Cool White
Vip Off Green	0	100	40	%	<b>Hall Call Vip Light Off Green Intensity</b>
Vip Off Red	0	100	100	%	<b>Hall Call Vip Light Off Red Intensity</b>
Vip On Blue	0	100	0	%	<b>Hall Call Vip Light On Blue Intensity</b>
Vip On Bright	0	100	100	%	<b>Hall Call Vip Light On Brightness</b>

Field Variable	Min	Max	Initial	Units	Description
<b>Table 7-12: CB, VIP HSec Call Lights</b>					
Vip On Color	0	15	0	color	<b>Hall Call Vip Light On Color</b> 0 Based on parameters 1 Red 2 Orange 3 Yellow 4 Chartreuse 5 Green 6 Aquamarine 7 Cyan 8 Azure 9 Blue 10 Violet 11 Magenta 12 Rose 13 Rose White 14 Warm White 15 Cool White
Vip On Green	0	100	40	%	<b>Hall Call Vip Light On Green Intensity</b>
Vip On Red	0	100	100	%	<b>Hall Call Vip Light On Red Intensity</b>

7.1.13 System Options Submenu

Field Variable	Min	Max	Initial	Units	Description
<b>Table 7-13: System Options</b>					
485 Port Sel	0	1	0	-	<b>485 Port Sel.</b> Selects the operation of 485 port. 485 com port select: 0 = IGEP if enabled 1 = EX-51 Hall Lantern
Auto Fault Dpy	0	1	0	-	<b>Automatic Fault Display.</b> Enable to automatically display a fault on the LCD screen. 0 = Disabled 1 = Enabled

Field Variable	Min	Max	Initial	Units	Description
<b>Table 7-13: System Options</b>					
Auto WIFI Setup	0	1	1	-	<b>Automatic WiFi Setup.</b> Turns on option to have controller automatically update Wi-Fi board for Galileo if connection is lost. 0 = Disabled 1 = Enabled
CAN Baud Rate	0	1	0	bps	<b>CAN Baud Rate.</b> Set to zero and do not change. Special jobs utilize a different baud rate for CAN Bus. All devices need to be reconfigured for new rate. CAN Baud Rate, 0 = 115.2K 1 = 57.6K
CAN Sync Count	0	7	4	count	<b>CAN Sync Count.</b> Frequency to update CAN Bus devices. Units are 1/4 seconds. It sets Synchronization Count in 250 millisecond increments
COM 1 Baud Rate	0	9	6	bps	<b>Com 1 User Interface Baud Rate.</b> Selects the bit rate of the COM 1 serial port. 0 = 2400 bps 1 = 4800 bps 2 = 9600 bps 3 = 19200 bps 4 = 38400 bps 5 = 57600 bps 6 = 115200 bps 7 = 219254 bps 8 = 226562.5 bps 9 = 234375 bps
Com 1 Port Sel	0	7	6	-	<b>Com 1 Port Select.</b> Selects the operation of COM 1 port. 0 = Comm Diag 1 = Comm Debug 2 = Galcom 3 = DL20 4 = Galcom Wireless 5 = Galcom Ethernet 6 = Galcom Wireless Flow Control 7 = Galcom Ethernet Flow Control

Field Variable	Min	Max	Initial	Units	Description
<b>Table 7-13: System Options</b>					
Com 2 Baud Rate	0	9	3	bps	<p><b>COM 2 User Interface Baud Rate.</b> Selects the bit rate of the COM 2 serial port.</p> <p>0 = 2400 bps                      1 = 4800 bps                      2 = 9600 bps                      3 = 19200 bps                      4 = 38400 bps                      5 = 57600 bps                      6 = 115200 bps                      7 = 219254 bps                      8 = 226562.5 bps                      9 = 234375 bps</p>
Com 2 Port Sel	0	7	0	-	<p><b>Com 2 Port Select.</b> Selects the operation of COM 2 port. 0 = Comm Diag                      1 = Comm Debug                      2 = Galcom                      3 = DL20                      4 = Galcom Wireless                      5 = Galcom Ethernet                      6 = Galcom Wireless Flow Control                      7 = Galcom Ethernet Flow Control</p>
CPU Tim Output	0	7	0	-	<p><b>CPU Timing Output.</b> The CPU has three test point pins that outputs timing signals depending upon the setting of this parameter. These are 5 Volt signals that can be monitored by an oscilloscope.</p> <p>0 = Z6 LED 1 second pulse                      1 = Inctime                      2 = GrpIO                      4 = 10 msec</p>
Drive Baud Rate	0	3	0	bps	<p><b>Drive Baud Rate.</b></p> <p>0 = 19200 (HPV-900, DSD-412, HPV-600 and Quattro Drives).                      1 = 38400                      2 = 57600 (KEB Drives)                      3 = 11500</p>
Drive Modbus	0	5	0	-	<p><b>Drive Modbus Protocol.</b> 0-5 = N1, N2, E1, E2, O1, O2 (Always 8 data bits, parity, stop bits). Used for Delta drive.</p>

Field Variable	Min	Max	Initial	Units	Description
<b>Table 7-13: System Options</b>					
Drv Update Rate	0	2	0	-	<b>Drive Command Update Rate.</b> Rate at which commands are sent to the drive. 0 = 10 msec (HPV-900, DSD-412, HPV-600 and Quattro Drives), 1 = 15 msec 2 = 20 msec
EE Memory Type	0	1	0	-	<b>EE Memory Type.</b> Selects the type of memory chip used with the TS-5600 CPU. 0 = STK16C88 1 = STK16C68. Not used with GALX-1100AN CPU board
Encoder Baud	0	1	0	bps	<b>Encoder CAN Open Baud Rate.</b> 0 = 250K 1 = 125K bits per second.
Encoder Intrvl	1	5	3	-	<b>Encoder Interval.</b> Defines the intervals for sampling the encoder reads for calculating speed. Default value of 3 will work on most jobs. For cars with distance feedback from pulses on a tape selector, a value of 5 will work best.
Encoder NodeID	1	127	63	-	<b>Encoder Node ID.</b> Selects the Node ID for the CAN Open encoder. Must be set to for the specific vendor's encoder (also see encoder type): Turck = 63 Dynapar = 1 Wachendorff = 127 Not used when Encoder Type = 4 (Tape Selector)
Encoder Sample	2	10	10	-	<b>Encoder Samples.</b> Determines the samples used to calculate the speed from the encoder. Default values should work in all jobs.
Encoder Type	0	4	0	-	<b>Encoder Type.</b> Selects type of encoder feedback used. 0 = Based on CONS file setting 1 = Turck CAN Open Encoder 2 = Dynapar CAN Open Encoder 3 = Wachendorff CAN Open Encoder 4 = Selector Tape

Field Variable	Min	Max	Initial	Units	Description
<b>Table 7-13: System Options</b>					
Exclusion FLT 1	0	Max Faults	0	fault	<b>Exclusion fault 1:</b> Set to fault code number. This prevents faults from being recorded in the fault log. It should only be set for nuisance and noncritical faults. Controller still goes through all the logic for each fault code except, a call is not recorded in the fault log.
Exclusion FLT 2	0	Max Faults	0	fault	<b>Exclusion fault 2:</b> Set to fault code number. This prevents faults from being recorded in the fault log. It should only be set for nuisance and noncritical faults. Controller still goes through all the logic for each fault code except, a call is not recorded in the fault log.
Exclusion FLT 3	0	Max Faults	0	fault	<b>Exclusion fault 3:</b> Set to fault code number. This prevents faults from being recorded in the fault log. It should only be set for nuisance and noncritical faults. Controller still goes through all the logic for each fault code except, a call is not recorded in the fault log.
Exclusion FLT 4	0	Max Faults	0	fault	<b>Exclusion fault 4:</b> Set to fault code number. This prevents faults from being recorded in the fault log. It should only be set for nuisance and noncritical faults. Controller still goes through all the logic for each fault code except, a call is not recorded in the fault log.
Exclusion FLT 5	0	Max Faults	0	fault	<b>Exclusion fault 5:</b> Set to fault code number. This prevents faults from being recorded in the fault log. It should only be set for nuisance and noncritical faults. Controller still goes through all the logic for each fault code except, a call is not recorded in the fault log.
Exclusion FLT 6	0	Max Faults	0	fault	<b>Exclusion fault 6:</b> Set to fault code number. This prevents faults from being recorded in the fault log. It should only be set for nuisance and noncritical faults. Controller still goes through all the logic for each fault code except, a call is not recorded in the fault log.
Galileo Group #	1	24	1	-	<b>Galileo Group Number.</b> Set group number to assign unique IP addresses on auto ethernet setup.



Field Variable	Min	Max	Initial	Units	Description
<b>Table 7-13: System Options</b>					
GMON Intrvl Tim	0	10	0.2	Sec	<b>GAL Monitor Interval Timer.</b> Controls the timer interval that data packets are transmitted. When zero, data is not transmitted on a time interval.
GMON Pkt Cntrl	0	7	0	-	<b>GAL Monitor Serial Output Packet Control.</b> This variable controls how the controller data is being packed and unpacked in the serial data.
GMON Upd Cntrl	0	3	0	-	<b>GAL Monitor Update Control.</b> Controls how the packet data on the serial port is updated.
KEB Dpy Type	0	1	0	-	<b>KEB Display Type.</b> 0 = Standard Red LED Display 1 = LCD Display <b>Power must be cycled for change in serial protocol.</b>
Low Bat Cap Lev	0	101	50	%	<b>For UPS Systems.</b> This is the battery level at which the controller will fault out due to Low Battery Capacity.
Low Door Volt	0	600	198	Vrms	<b>Low Door Voltage.</b> Settings for Line Voltage Monitor Board. It sets the value of voltage for 'Door Low Voltage Fault' to be triggered.
Low Line Volt	0	600	198	Vrms	<b>Low Line Voltage.</b> Settings for Line Voltage Monitor Board. It sets the value of voltage for a 'Low Line Voltage Fault' to be triggered.
Password	0	9999	0	-	<b>Password Code</b> to modify and adjust field variables.
PI Message Type	0	1	0	-	<b>PI Message Type.</b> When set advanced PI message is used (packet 125 instead of packet 25). 0 = Disable +1 = Enable +2 = Act Voice Msg at Dwel +4 = PI Display IN during VIP
Pword Time-out	0	3200	300	sec	<b>Password Time-out.</b> The amount of inactive time for the LCD to lock out the field variables.

Field Variable	Min	Max	Initial	Units	Description
<b>Table 7-13: System Options</b>					
RS485 COM Baud	0	6	0	bps	<b>RS485 COM Baud Rate.</b> 0 = 2400 1 = 4800 2 = 9600 3 = 19.2K 4 = 38.4K 5 = 57.6K 6 = 115.2K bits per second
Safe Test Day	1	31	0	day	<b>Safety Test Day.</b>
Safe Test Month	1	12	0	month	<b>Safety Test Month.</b>
Safe Test Year	2000	2999	0	year	<b>Safety Test Year.</b>
Service UPS	0	1	0	-	<b>Service UPS mode.</b> Turning this parameter ON disables UPS faults. It should only be used in Construction mode or while servicing the UPS.
UPS Baud Rate	0	3	2	bps	<b>UPS Baud Rate:</b> 0 = 2400 1 = 4800 2 = 9600 3 = 19200
Video Time out	0	3200	0	sec	<b>Video Time-out.</b> Turn off the machine room video after this timer expires This function is disabled when set to zero.

## 7.2 Safety Processor Adjustable Variables

Field Variable	Min	Max	Initial	Units	Description
<b>Table – 7-14: Safety Processor Adjustable Variables</b>					
2 Stop	0	1	0	-	<b>2 Stop.</b> Set to 1 if this car travels to only two landings. This parameter tells the Safety Processor that there are no middle door locks.

Field Variable	Min	Max	Initial	Units	Description
<b>Table – 7-14: Safety Processor Adjustable Variables</b>					
Buffer Type	0	1	0	-	<b>Buffer Type.</b> This parameter is set to 1 when there is a reduced stroke buffer and enables the use of the ETU and ETD verification limits. <b>This parameter must match the jumper setting for the PAL on the 1102 board AND the job configuration setting for reduced stroke buffer in the configuration file.</b> If all three do not match, the car is not allowed to run.
CAN Baud Rate	0	1	0	bps	<b>CAN Baud Rate.</b> Set the baud rate for the CAN Bus. 0 = 115.2K 1 = 57.6K
Comm Chk Dis	0	1	0	-	<b>Communications Check.</b> This parameter disables the CAN Bus communications check. This is variable allows a new Safety Processor Board to be used on older GALaxy I or II controllers that did not use CAN Bus communications. On GALaxy III controllers, the main CPU must have Can Bus communications.
Control Type	0	2	0	-	<b>Control Type.</b> Type of controller used. 0 = Hydro 1 = Traction Non-Distance Feedback 2 = Traction Distance Feedback.
DT Count	0	10000	12	count	<b>DT Count.</b> Number of pulse counts after the DT limit is hit where the slowdown velocity check is made. Not used for GALaxy IV.
DTS Velocity	0	1600	200	fpm	<b>Down Emergency Terminal Slowdown Velocity.</b> Maximum velocity to hit the down terminal slowdown limit. Hitting the limit at a higher velocity will cause the Safety Processor board to shut the car down from a velocity error. For cars with speeds greater than 200 fpm.
Encoder Dir	0	1	0	-	<b>Encoder Direction.</b> Determines if rotation for the up direction is clockwise or counterclockwise. 0 = CW1 = CCW
Encoder PPR	10	18000	2048	PPR	<b>Encoder PPR.</b> Pulses Per Revolution of the Encoder.

Field Variable	Min	Max	Initial	Units	Description
<b>Table – 7-14: Safety Processor Adjustable Variables</b>					
Encoder RPM	2.5	1800	105	RPM	<b>Encoder RPM.</b> Revolutions Per Minute of the Encoder.
Encoder Type	0	4	0	-	<b>Encoder Type.</b> Type of feedback used by the Safety Processor to calculate the car's velocity. 0 = Standard Tape 1 = Governor Encoder 2 = Encoded Tape 3 = Governor Pulses 4 = Incremental Encoder
ETS Down Vel	0	1600	200	fpm	<b>Emergency Terminal Slowdown Down (ETD) Velocity.</b> Maximum velocity to hit the down emergency terminal slowdown limit. Hitting the limit at a higher velocity than set by this parameter will cause the Safety Processor board to shut the car down from a velocity error. This limit is only used for Reduced Stroke Buffer.
ETS Setup Mode	0	2	0	-	<b>ETS Setup Mode.</b> 0 = Normal operation. The PAL parameters for ETS Up and Down Velocities cannot be modified. The ETSLD TST jumper on the 1102 board must match the ETS Setup Mode parameter for the car to run. 1 = PAL velocity setup mode. Parameters can be modified but the ETSLD TST jumper must also be placed on 1102 board. 2 = Power up debug mode.
ETS Up Vel	0	1600	200	fpm	<b>Emergency Terminal Slowdown Up (ETU) Velocity.</b> Maximum velocity to hit the up emergency terminal slowdown limit. Hitting the limit at a higher velocity than set by this parameter will cause the Safety Processor board to shut the car down from a velocity error. This limit is only used for Reduced Stroke Buffer.
Insp Velocity	0	200	140	fpm	<b>Inspection Velocity.</b> Maximum velocity the car is allowed to run on inspection.
Leveling Vel	0	200	140	fpm	<b>Leveling Velocity.</b> Maximum velocity the car is allowed to run while leveling with the door open.

Field Variable	Min	Max	Initial	Units	Description
<b>Table – 7-14: Safety Processor Adjustable Variables</b>					
PAL ETS Dn Vel	0	1600	200	fpm	<b>PAL ETSLD Dn Velocity.</b> When the car is setup with reduced stroke buffer, if the car hits the Down ETS limit at a velocity greater than this value, the PAL will drop the RUN and Brake contactors to stop the car. See also Buffer Type). Note: This value is entered in fpm but is recalculated in pulses per 30 msec for the PAL device. The value may be changed to the nearest valid fpm after entered.
PAL ETS Up Vel	0	1600	200	fpm	<b>PAL ETSLD Up Velocity.</b> When the car is setup with reduced stroke buffer, if the car hits the Up ETS limit at a velocity greater than this value, the PAL will drop the RUN and Brake contactors to stop the car. See also Buffer Type). Note: This value is entered in fpm but is recalculated in pulses per 30 msec for the PAL device. The value may be changed to the nearest valid fpm after entered.
Pulse Flt Tmr	1	10	2	sec	<b>Pulse Count Fault Delay Time.</b> Time delay to detect that the selector pulses have stopped.
Pulses Per Ft	1	3200	16	ppf	<b>Pulses Per Foot.</b> Number of pulses in one foot.
Rear Doors	0	1	0	-	<b>Rear Door.</b> Indicates that the car has rear doors and the Safety Processor should verify the rear door gate and locks.
Short Floor	0	3	0	-	<b>Short Floor.</b> There is a short floor at the top or bottom landing. This parameter informs the safety processor that the car can be on a floor next to the terminal landing and have the terminal limits still active. 0 = None 1 = Top 2 = Bot 3 = Both
Soft Stop Time	1	10	1	sec	<b>Soft Stop Timer.</b> During a soft stop, the speed command is brought to zero, then the brake is dropped and finally the run outputs are turned off. This timer is used to keep the run outputs from timing out during a soft stop.

Field Variable	Min	Max	Initial	Units	Description
<b>Table – 7-14: Safety Processor Adjustable Variables</b>					
Speed Chk Dis	0	1	0	-	<b>Speed Check.</b> If the car speed is 150 fpm or less, the Safety Processor Speed Check can be disabled from this variable. If the speed is greater than 150 fpm, the variable can still be set but the speed check is made anyway. The speed check function, verifies the car speed on inspection, in leveling with the door open and when the UT, DT, UTS and DTS limits are hit. The Safety Processor will also shut the car down if it stops getting pulses while the car is running (has an up or down run signal).
Top Speed	25	2000	200	fpm	<b>Top Speed</b> or contract speed of the car.
UMotion Ck Dis	0	1	0	-	<b>Unintended Motion Check</b> 0 = Motion check 1 = Disable unintended motion check
UT Count	0	10000	12	count	<b>UT Count.</b> Number of pulse count after the UT limit is hit where the slowdown velocity check is made.  Not used for GALaxy IV.
UTS Velocity	0	1600	200	fpm	<b>Up Emergency Terminal Slowdown Velocity.</b> Maximum velocity to hit the up terminal slowdown limit. Hitting the limit at a higher velocity will cause the Safety Processor board to shut the car down from a velocity error. For cars with speeds greater than 200 fpm.
Vel Flt Timer	0.1	0.5	0.18	sec	<b>Velocity Fault Delay Time.</b> Time delay after a velocity fault to shut the car down.

### 7.3 NTS Processor Adjustable Variables

Field Variable	Min	Max	Initial	Units	Description
<b>Table 7-15: NTS Processor Adjustable Variables</b>					
CAN Baud Rate	0	1	0	bps	<b>CAN Baud Rate.</b> Set the baud rate for the CAN Bus. 0 = 115.2K 1 = 57.6K

Field Variable	Min	Max	Initial	Units	Description
<b>Table 7-15: NTS Processor Adjustable Variables</b>					
Debug Mode	0	1	0	-	<b>Debug Mode</b>
DT Velocity	0	1600	350	fpm	<b>Down Terminal Slowdown Velocity.</b> Maximum velocity to hit the down terminal slowdown limit. Hitting the limit at a higher velocity will cause the NTS Processor to drop the NTSD output to the drive. Removal of the signal will cause the drive to execute an emergency timed slowdown until the car reaches leveling speed. The car will stop when the terminal landing is reached.
DT1 Velocity	0	1600	450	fpm	<b>Down Terminal 1-6 Slowdown Velocity.</b> Maximum velocity to hit the down terminal slowdown limit. Hitting the limit at a higher velocity will cause the NTS Processor to drop the NTSD output to the drive. Removal of the signal will cause the drive to execute an emergency timed slowdown until the car reaches leveling speed. The car will stop when the terminal landing is reached.
DT2 Velocity	0	1600	550	fpm	<b>Down Terminal 1-6 Slowdown Velocity.</b> Maximum velocity to hit the down terminal slowdown limit. Hitting the limit at a higher velocity will cause the NTS Processor to drop the NTSD output to the drive. Removal of the signal will cause the drive to execute an emergency timed slowdown until the car reaches leveling speed. The car will stop when the terminal landing is reached.
DT3 Velocity	0	1600	650	fpm	<b>Down Terminal 1-6 Slowdown Velocity.</b> Maximum velocity to hit the down terminal slowdown limit. Hitting the limit at a higher velocity will cause the NTS Processor to drop the NTSD output to the drive. Removal of the signal will cause the drive to execute an emergency timed slowdown until the car reaches leveling speed. The car will stop when the terminal landing is reached.
DT4 Velocity	0	1600	750	fpm	<b>Down Terminal 1-6 Slowdown Velocity.</b> Maximum velocity to hit the down terminal slowdown limit. Hitting the limit at a higher velocity will cause the NTS Processor to drop the NTSD output to the drive. Removal of the signal will cause the drive to execute an emergency timed slowdown until the car reaches leveling speed. The car will stop when the terminal landing is reached.

Field Variable	Min	Max	Initial	Units	Description
<b>Table 7-15: NTS Processor Adjustable Variables</b>					
DT5 Velocity	0	1600	850	fpm	<b>Down Terminal 1-6 Slowdown Velocity.</b> Maximum velocity to hit the down terminal slowdown limit. Hitting the limit at a higher velocity will cause the NTS Processor to drop the NTSD output to the drive. Removal of the signal will cause the drive to execute an emergency timed slowdown until the car reaches leveling speed. The car will stop when the terminal landing is reached.
DT6 Velocity	0	1600	950	fpm	<b>Down Terminal 1-6 Slowdown Velocity.</b> Maximum velocity to hit the down terminal slowdown limit. Hitting the limit at a higher velocity will cause the NTS Processor to drop the NTSD output to the drive. Removal of the signal will cause the drive to execute an emergency timed slowdown until the car reaches leveling speed. The car will stop when the terminal landing is reached.
Encoder PPR	10	20000	2048	PPR	<b>Encoder PPR.</b> Pulses Per Revolution of the Encoder.
Encoder RPM	1	3000	1170	RPM	<b>Encoder RPM.</b> Revolutions Per Minute of the Encoder.
Encoder Type	0	1	0	-	<b>Encoder Type.</b> Type of feedback used by the Safety Processor to calculate the car's velocity. 0 = Tape 1 = Motor Encoder.
Top Speed	0	1600	350	fpm	<b>Top Speed</b> or contract speed of the car.
UT Velocity	0	1600	350	fpm	<b>Up Terminal Slowdown Velocity.</b> Maximum velocity to hit the up terminal slowdown limit. Hitting the limit at a higher velocity will cause the NTS Processor to drop the NTSD output to the drive. Removal of the signal will cause the drive to execute an emergency timed slowdown until the car reaches leveling speed. The car will stop when the terminal landing is reached.



Field Variable	Min	Max	Initial	Units	Description
<b>Table 7-15: NTS Processor Adjustable Variables</b>					
UT1 Velocity	0	1600	450	fpm	<b>Up Terminal 1-6 Slowdown Velocity.</b> Maximum velocity to hit the up terminal slowdown limit. Hitting the limit at a higher velocity will cause the NTS Processor to drop the NTSD output to the drive. Removal of the signal will cause the drive to execute an emergency timed slowdown until the car reaches leveling speed. The car will stop when the terminal landing is reached.
UT2 Velocity	0	1600	550	fpm	<b>Up Terminal 1-6 Slowdown Velocity.</b> Maximum velocity to hit the up terminal slowdown limit. Hitting the limit at a higher velocity will cause the NTS Processor to drop the NTSD output to the drive. Removal of the signal will cause the drive to execute an emergency timed slowdown until the car reaches leveling speed. The car will stop when the terminal landing is reached.
UT3 Velocity	0	1600	650	fpm	<b>Up Terminal 1-6 Slowdown Velocity.</b> Maximum velocity to hit the up terminal slowdown limit. Hitting the limit at a higher velocity will cause the NTS Processor to drop the NTSD output to the drive. Removal of the signal will cause the drive to execute an emergency timed slowdown until the car reaches leveling speed. The car will stop when the terminal landing is reached.
UT4 Velocity	0	1600	750	fpm	<b>Up Terminal 1-6 Slowdown Velocity.</b> Maximum velocity to hit the up terminal slowdown limit. Hitting the limit at a higher velocity will cause the NTS Processor to drop the NTSD output to the drive. Removal of the signal will cause the drive to execute an emergency timed slowdown until the car reaches leveling speed. The car will stop when the terminal landing is reached.
UT5 Velocity	0	1600	850	fpm	<b>Up Terminal 1-6 Slowdown Velocity.</b> Maximum velocity to hit the up terminal slowdown limit. Hitting the limit at a higher velocity will cause the NTS Processor to drop the NTSD output to the drive. Removal of the signal will cause the drive to execute an emergency timed slowdown until the car reaches leveling speed. The car will stop when the terminal landing is reached.

Field Variable	Min	Max	Initial	Units	Description
<b>Table 7-15: NTS Processor Adjustable Variables</b>					
UT6 Velocity	0	1600	950	fpm	<b>Up Terminal 1-6 Slowdown Velocity.</b> Maximum velocity to hit the up terminal slowdown limit. Hitting the limit at a higher velocity will cause the NTS Processor to drop the NTSD output to the drive. Removal of the signal will cause the drive to execute an emergency timed slowdown until the car reaches leveling speed. The car will stop when the terminal landing is reached.
Velocity Dir	0	1	0	-	<b>Velocity Direction.</b> Used to invert the direction of the NTS velocity. 0 = Normal 1 = Invert

### 7.4 APS Selector Adjustable Variables

Field Variable	Min	Max	Initial	Units	Description
<b>Table 7-16: APS Selector Adjustable Variables</b>					
Can Baud Rate	0	1	0	bps	<b>CAN Baud Rate.</b> Set to zero and do not change. Special jobs utilize a different baud rate for CAN Bus. All devices would need to be reconfigured for new rate. CAN Baud Rate, 0 = 115.2K 1 = 57.6K
Debug Mode	0	7	0	-	<b>Debug Mode</b>
Num of Limits	1	8	1	-	<b>Number of Limits</b>
Number Valid Fl	2	Top Floor	2	-	<b>Number of Valid Floors</b>
Top Speed	0	1600	200	fpm	<b>Top Speed</b> or contract speed of the car.
UT/DT Dist	0	32000	0	inches	<b>UT/DT Limit Distance</b>
UT1/DT1 Dist	0	32000	0	inches	<b>UT1/DT1 Limit Distance</b>

Field Variable	Min	Max	Initial	Units	Description
<b>Table 7-16: APS Selector Adjustable Variables</b>					
UT2/DT2 Dist	0	32000	0	inches	<b>UT2/DT2 Limit Distance</b>
UT3/DT3 Dist	0	32000	0	inches	<b>UT3/DT3 Limit Distance</b>
UT4/DT4 Dist	0	32000	0	inches	<b>UT4/DT4 Limit Distance</b>
UT5/DT5 Dist	0	32000	0	inches	<b>UT5/DT5 Limit Distance</b>
UT6/DT6 Dist	0	32000	0	inches	<b>UT6/DT6 Limit Distance</b>

<b>Table 7-17: Velocity Slowdown Table</b>				
FPM	UT/ DT	UT1/ DT1	UT2/ DT2	UT3/ DT3
50	5"			
75	9"			
100	12"			
150	21"			
200	30"			
250	45"			
300	25"	50"		
350	33"	65"		
400	41"	83"		
450	51"	102"		
500	56"	113"		
600	52"	105"	157"	
700	70"	140"	209"	
800	67"	135"	202"	269"
900	77"	153"	230"	306"

## Section 8 – Appendix A

---



**Every safety precaution, whether or not specifically stated in this document, must be implemented when installing, adjusting, or servicing elevator equipment. All safety precautions must be followed to ensure the safety of elevator personnel and the general public.**



**The test procedures outlined in this Appendix provide a guide for elevator personnel to perform the specific tests in this Appendix. These test procedures are not intended to override or circumvent any procedure or test that is mandated by the applicable codes and the Authority Having Jurisdiction.**



**All temporary connections must be removed before placing the elevator in service.**



**If there are any questions in regard to the procedures for performing these tests with a GALaxy IV controller, please call GAL Manufacturing toll free at 1-(877) 425-7778 for free technical assistance.**

### 8.1 Testing Precheck

---

Before attempting any tests, you must make sure that the following velocities all match while on inspection:

Dmd Vel - CPU Demand Velocity  
Enc Vel - Encoder Velocity  
Drv Vel - Drive Velocity  
SPB Vel - Safety Processor Velocity  
NTS Vel - NTS Processor Velocity

These velocities can be monitored at “Elevator Status”->Enter->Scroll Up or Down until you find each of the following: DMD, VEL, SPB VEL and NTS VEL.

The Drive Velocity can be monitored in the Trace I/O Screen if you have a monitor or in the M1000 drive parameter D1 SPEED FEEDBACK.

It is useful to confirm the velocity readings by using a handheld tachometer on the machine.

The encoder pulses must also be verified. On the same screen where you see DMD & VEL (above) you will also see “DP=”, this number should increment as the car goes up and should decrement as the car goes down. If the “DP” count does not increment and decrement properly, complete the procedures in section 3.3.3, “Verify the Encoder Direction for the Main CPU”.

## 8.2 Learn Limit Velocities

---

- 1) Go to “Elevator Setup -> Learn Limit Velocities” and follow the prompts.
- 2) Be sure to press “Enter” when asked to Preset Limit Velocities, this will set all limits to contract speed before learning the limits. Failure to do so may prevent the limits from being learned properly.
- 3) After the limits are learned please verify that they were learned properly, check the following:
- 4) “Elevator Setup” -> DT/UT, DT1/UT1, DTS/UTS Slowdown Clamps.
- 5) “Adjustable Variables -> NTS Proc Adj Vars” -> UT/DT/UT1/DT1 Velocities.
- 6) “Adjustable Variables -> Safety Proc Adj Vars” -> UTS/DTS Velocity.
- 7) These values can be further adjusted manually if necessary.

## 8.3 Emergency Terminal Speed Limiting Device

---

The ETSLD is only required when reduced stroke buffers are used.

The SAF-PROC processor reads the state and position of the emergency terminal stopping switches mounted in the hoistway. If a fault is detected, power is removed from the driving-machine motor, the driving-machine brake, and the emergency brake.

The SAF-PAL also monitors speed and the emergency terminal stopping switches mounted in the hoistway and can remove power from the driving-machine motor and brake independent of the SAF-PROC.

Separate speed verification (microprocessor and discrete logic), separate hoist-way switches, and separate speed references are used to ensure that the sensing device of ETSLD [2.25.4.1] is independent of the normal speed control system, per 2.25.4.1.2.

For redundancy, two separate magnetic switches are used for the ETSLD function, per 2.25.4.1.9.

### 8.3.1 Testing ETSLD At The Bottom Terminal Landing

---

- 1) Prior to the test, the “Learn Limit Velocities” and “ETSLD Setup” procedures must be completed. Verify that the “ETSLD TEST” jumper is removed from the 1102 board, and that the “Safety Proc Adj Vars” parameter “ETS Setup Mode = 0”. This test will be run twice, once with the “ETS” input temporarily connected to terminal “S10” and the second time with the “DTS” input temporarily connected to terminal “S10”.
- 2) Position the car at an intermediate floor where the “ETS” input is on. Install a temporary connection from the “ETS” terminal to the “S10” terminal on the 1102 board. This will prove that the function operates properly if the “ETS” input fails in the “ON” state.
- 3) From the Controller’s LCD display, select the “Elevator Setup” menu and then select “Emergency Term SD Test”. Follow the instructions displayed to run the car in the down direction. Keep in mind that when switching the car from inspection to normal, there will be a 5 second delay. When the test is initiated the car will run to the bottom terminal landing. When the remaining ETSLD switch (DTS or ETS), that is not temporarily disabled, is actuated, power will be removed from the driving-machine motor, driving-machine brake, and emergency brake.
- 4) Observe that when the (DTS or ETS) switch is activated the car does an emergency stop (removes power from the brake, emergency brake and machine). After the car stops (for the “Fault Time” set in the Adjustable Variables -> Car Timers menu) the car will then move to a floor.
- 5) Remove the temporary connection from the “ETS” terminal to the “S10” terminal on the 1102 board. Position the car at an intermediate floor where the “DTS” input is on. Install a temporary connection

from the “DTS” terminal to the “S10” terminal on the 1102 board. Repeat procedure in steps 2 through 4.

- 6) Remove the temporary connection from the “DTS” input. Run the car to the bottom landing. Temporarily connect the “ETS” input to “S10”. A “Terminal Limit Flt” status will be displayed on the status screen and an “ETS Failed On Bot FI” will be recorded in the fault log. Verify that the car is not allowed to run from the floor. To restore the car to normal operation, remove all temporary connections, move the controller inspection switch to the INSP position and then back to NORM.
- 7) With the car at the bottom landing, temporarily connect the “DTS” input to “S10”. A “Terminal Limit Flt” status will be displayed on the status screen and an “DTS Failed On Fault” will be recorded in the fault log. Verify that the car is not allowed to run from the floor. To restore the car to normal operation, remove all temporary connections, move the controller inspection switch to the INSP position and then back to NORM.
- 8) After the tests are completed, remove all temporary connections.

### 8.3.2 Testing ETSLD At The Top Terminal Landing

---

- 1) Prior to the test, the “Learn Limit Velocities” and “ETSLD Setup” procedures must be completed. Verify that the “ETSLD TEST” jumper is removed from the 1102 board, and that the “Safety Proc Adj Vars” parameter “ETS Setup Mode = 0”. This test will be run twice, once with the “ETS” input temporarily connected to terminal “S10” and the second time with the “UTS” input temporarily connected to terminal “S10”.
- 2) Position the car at an intermediate floor where the “ETS” input is on. Install a temporary connection from the “ETS” terminal to the “S10” terminal on the 1102 board. This will prove that the function operates properly if the “ETS” input fails in the “ON” state.
- 3) From the Controller’s LCD display, select the “Elevator Setup” menu and then select “Emergency Term SD Test”. Follow the instructions displayed to run the car in the up direction. Keep in mind that when switching the car from inspection to normal, there will be a 5 second delay. When the test is initiated the car will run to the top terminal landing. When the ETSLD switch is actuated, power will be removed from the driving-machine motor, driving-machine brake, and emergency brake.
- 4) Observe that when the (UTS or ETS) switch is activated the car does an emergency stop (removes power from the brake, emergency brake and machine). After the car stops (for the “Fault Time” set in the Field Variables-Car Timers menu) the car will then move to a floor.
- 5) Remove the temporary connection from the “ETS” terminal to the “S10” terminal on the 1102 board. Position the car at an intermediate floor where the “UTS” input is on. Install a temporary connection from the “UTS” terminal to the “S10” terminal on the 1102 board. Repeat procedure in steps 2 through 4.
- 6) Remove the temporary connection from the “UTS” input. Run the car to the top landing. Temporarily connect the “ETS” input to “S10”. A “Terminal Limit Flt” status will be displayed on the status screen and an “ETS Failed On Top FI” will be recorded in the fault log. Verify that the car is not allowed to run from the floor. To restore the car to normal operation, remove all temporary connections, move the controller inspection switch to the INSP position and then back to NORM.
- 7) With the car at the top landing, temporarily connect the “UTS” input to “S10”. A “Terminal Limit Flt” status will be displayed on the status screen and an “UTS Failed On Fault” will be recorded in the fault log. Verify that the car is not allowed to run from the floor. To restore the car to normal operation, remove all temporary connections, move the controller inspection switch to the INSP position and then back to NORM.
- 8) After the tests are completed remove all temporary connections.

## 8.4 Emergency Terminal Stopping device

---

Emergency Terminal Stopping Devices are only required on elevators with static control and rated speeds over 1 m/s (200 ft/min). Elevators that already have Emergency Terminal Speed Limiting Devices are not required to also have Emergency Terminal Stopping Devices.

Magnetic limit switches are arranged at the terminal limits. The Main Processor checks the speed and position of the elevator whenever one of these magnetic switches opens. If a velocity or position fault is detected, the elevator will do an emergency slowdown to the next floor.

The Safety Processor monitors the speed at which the UTS and DTS switches are activated. If the car is above the set speed when the UTS or DTS switches opens, the SAF-PROC processor removes power from the driving machine and brake.

If the elevator uses a reduced stroke buffer skip this test because ETSLD test was performed.

### 8.4.1 Testing ETSD At The Bottom Terminal Landing

---

- 1) Prior to the test, the “Learn Limit Velocities” procedure must be completed. Verify that the limit trip velocities are valid. This can be done by verifying that the “Adjustable Variables” -> “Safety Proc Adj Vars” -> “DTS Velocity is less than contract speed.
- 2) From the Controller’s LCD display, select the “Elevator Setup” menu and then select “Emergency Term SD Test”. Follow the instructions displayed to run the car in the down direction. Keep in mind that when switching the car from inspection to normal, there will be a 5 second delay. When the test is initiated the car will run to the bottom terminal landing.
- 3) When the ETSD switch “DTS” is actuated, verify that power is removed from the driving-machine motor and brake. After the car stops (for the “Fault Time” set in the Field Variables-Car Timers menu) the car will then move to a floor.

### 8.4.2 Testing ETSD At The Top Terminal Landing

---

- 1) Prior to the test, the “Learn Limit Velocities” procedure must be completed. Verify that the limit trip velocities are valid. This can be done by verifying that the “Adjustable Variables” -> “Safety Proc Adj Vars” -> “UTS Velocity is less than contract speed.
- 2) From the Controller’s LCD display, select the “Elevator Setup” menu and then select “Emergency Term SD Test”. Follow the instructions displayed to run the car in the up direction. Keep in mind that when switching the car from inspection to normal, there will be a 5 second delay. When the test is initiated the car will run to the top terminal landing.
- 3) When the ETSD switch “UTS” is actuated, verify that power is removed from the driving-machine motor and brake. After the car stops (for the “Fault Time” set in the Field Variables-Car Timers menu) the car will then move to a floor.

## 8.5 NTSD – Normal Terminal Stopping Device

---

The NTS Processor functions independently from the Safety processor and Main processor. If the elevator activates the terminal switches above the learned velocity, the NTS processor will turn off the NTSD outputs. The NTSD output feeds an Emergency Slowdown input on the drive. When the Emergency Slowdown input turns off, the drive will perform an emergency slowdown specified by its own internal rate. The elevator will continue to slow down until the car speed reaches the drive’s internal leveling speed, and

then the elevator will continue at leveling speed until it arrives and stops at floor level at the terminal landing.

### 8.5.1 Test The Top and Bottom Normal Limits

---

- 1) Position the car at the bottom floor.
- 2) Put the car on inspection, which will render the normal elevator stopping means inoperative.
- 3) Run the car down on inspection until it stops. Notice the DN led should be off.
- 4) Put the car on Automatic and position the car at the top floor.
- 5) Put the car on inspection, which will render the normal elevator stopping means inoperative.
- 6) Run the car up on inspection until it stops. Notice the UN led should be off.
- 7) Remove the car from inspection.

### 8.5.2 Testing NTSD At The Bottom Terminal Landing

---

- 1) Prior to the test, the “Learn Limit Velocities” procedure must be completed. Verify that the limit trip velocities are valid. This can be done by verifying that the “Adjustable Variables” -> “NTS Proc Adj Vars” -> “DT’s” Velocities are less than contract speed.
- 2) Also verify that the drive is setup with the correct emergency speed profile parameters and will perform a slowdown when the NTSD signal to the drive is removed.
- 3) Install a temporary connection from UTS, DTS and ETS (if applicable) inputs on the 1102 main I/O board to S10.
- 4) From the Controller’s LCD display, select the “Elevator Setup” menu and then select “Normal Terminal SD Test”. Follow the instructions displayed to run the NTSD Test in the down direction. Do not select the NTSD Trip function. Keep in mind that when switching the car from inspection to normal, there will be a 5 second delay. When the test is initiated the car will run to the bottom terminal landing.
- 5) Observe that when the DT switch furthest from the landing activates, the car will do an emergency slowdown and stop at or near the landing. When the test is complete the LCD display should read “Limit Test Complete Press Mode for Menu”.
- 6) Remove all temporary connections from UTS, DTS, and ETS (if applicable) to S10.

### 8.5.3 Testing NTSD At The Top Terminal Landing

---

- 1) Prior to the test, the “Learn Limit Velocities” procedure must be completed. Verify that the limit trip velocities are valid. This can be done by verifying that the “Adjustable Variables” -> “NTS Proc Adj Vars” -> “UT’s” Velocities are less than contract speed.
- 2) Also verify that the drive is setup with the correct emergency speed profile parameters and will perform a slowdown when the NTSD signal to the drive is removed.
- 3) Install a temporary connection from UTS, DTS and ETS (if applicable) inputs on the 1102 main I/O board to S10.
- 4) From the Controller’s LCD display, select the “Elevator Setup” menu and then select “Normal Terminal SD Test”. Follow the instructions displayed to run the NTSD Test in the up direction. Do not select the NTSD Trip function. Keep in mind that when switching the car from inspection to normal, there will be a 5 second delay. When the test is initiated the car will run to the bottom terminal landing.
- 5) Observe that when the UT switch furthest from the landing activates, the car will do an emergency slowdown and stop at or near the landing. When the test is complete the LCD display should read “Limit Test Complete Press Mode for Menu”.
- 6) Remove all temporary connections from UTS, DTS and ETS (if applicable) to S10.



## 8.6 Ascending Car Overspeed

---

Note 1: Governor over-speed switch, device meets 2.26.4.3

Note 2: Main processor monitors the speed of the car and if an overspeed is detected will apply the emergency brake while also removing power from the driving machine and normal brake. Detection means meet the requirements of 2.19.1.2(a)(1)(b).

### 8.6.1 Test Ascending Car Overspeed From Governor Switch

---

- 1) When the governor switch opens, the controller will drop the power to the rope gripper or emergency brake circuit. If the “Adjustable Variables -> Car Options -> GOV Gripper/EBK” parameter is set to a 0 then the Gripper/EBK fault is latched immediately and will require a manual reset. If the parameter is set to 1, the Gripper/EBK fault is latched only if the elevator is moving so that if the switch is opened by hand without elevator motion, it will reset the Gripper/EBK fault automatically once the switch is closed.

On the controller's LCD display, verify the parameter “Adjustable Variables -> Car Options -> GOV Gripper/EBK” is set to a 1. To simulate an over-speed condition, put the car on inspection mode and then operate the governor mechanism by hand. To restore the car to normal operation, reset the governor over-speed switch. If the “GOV Gripper/EBK” parameter is set to a 1 then the rope gripper will reset upon reactivation of the governor over-speed switch otherwise go to “Reset / View Faults -> Reset Gripper/EBK Fault” and follow the displayed instructions to reset the Gripper/Emergency brake. Take the car off inspection mode.

- 2) To perform an Ascending car over-speed test, the mechanic should follow the required precautions and procedures set forth in the local and national elevator codes.
  - a. With the car on automatic, run the car to the bottom floor.
  - b. Refer to governor trip speed and governor overspeed switch speed listed on the governor data tag. Calculate a value half way between the overspeed switch value and the trip speed value. If the contract speed is 150 fpm or less, the calculated value will need to be set greater than the governor trip speed value. This value is the desired speed at which the test should be conducted.
  - c. For a KEB Combivert F5 drive:
    - i. Set KEB “Tune Parameters” -> “LL16 Overspeed Test Speed” to the desired test speed.
    - ii. Set KEB “Tune Parameters: -> “LL15 Overspeed Test” to “start”
  - d. For the Magnetek M1000 AC drive:
    - i. Access the A1 Ovrspd Tst Mult parameter in the drive and set the % over-speed to the calculated % overspeed, i.e.,  $\% \text{ overspeed} = (\text{desired speed} * 100) / (\text{contract speed})$ .
    - ii. If the calculated value of % overspeed is greater than 150%, increase the CONTRACT MTR SPD parameter on the drive to the appropriate rpm to achieve the correct overspeed amount.
    - iii. Set the U4 Overspeed Test to “Enable” in the drive. This will cause the drive to run over speed for one run. If the CONTRACT MTR SPD parameter was used this step can be skipped.
  - e. Select the “Elevator Setup” menu and then “Overspeed Test” menu and follow instructions on the LCD display to run the test in the up direction. After the test is complete, reset the governor and reset all drive parameters back to the appropriate values.

### 8.6.2 Test Ascending Car Overspeed Stopping With Emergency Brake Only

---

- 3) Perform an Ascending Car Overspeed test to verify that the elevator will be stopped by only the Rope Gripper or Emergency Brake:
  - a. With the car on automatic, run the car to the bottom floor.
  - b. Refer to governor trip speed and governor overspeed switch speed listed on the governor data tag. Calculate a value greater than the overspeed switch value but less than the trip speed value. If the contract speed is 150 fpm or less, the calculated value will need to be set greater than the governor trip speed value. This value is the desired speed at which the test should be conducted.
  - c. Power off the controller. Install temporary connections from RG5 to RG7 and from GOV to S10. Power up the controller.
  - d. From the Controller's LCD display, select the "Elevator Setup" menu and then select "Emergency Brake Test". Follow the instructions displayed to run the Emergency Brake Test in the up direction. Keep in mind that when switching the car from inspection to normal, there will be a 5 second delay.
  - e. When prompted from the LCD display, select to run the over speed test and also enter the desired over speed velocity.
  - f. When prompted from the LCD display to set the "Drv Ovspd", follow drive overspeed setup below:
    - i. For a KEB Combivert F5 drive:
      1. Set KEB "Tune Parameters" -> "LL16 Overspeed Test Speed" to the desired test speed.
      2. Set KEB "Tune Parameters: -> "LL15 Overspeed Test" to "start"
    - ii. For the Magnetek M1000 drive:
      1. Access the A1 Ovrsprd Tst Mult parameter in the drive and set the % overspeed to the calculated % overspeed, i.e.,  $\% \text{ overspeed} = (\text{desired speed} * 100) / (\text{contract speed})$ .
      2. If the calculated value of % overspeed is greater than 150%, increase the CONTRACT MTR SPD parameter on the drive to the appropriate rpm to achieve the correct overspeed amount.
      3. Set the U4 Overspeed Test to "Enable" in the drive. This will cause the drive to run over speed for one run. If the CONTRACT MTR SPD parameter was used this step can be skipped.
  - g. Press Enter on the LCD display to start the test.
  - h. When the test is initiated the car will accelerate to the over speed velocity. Once the required speed is obtained, the drive is turned off and the Emergency Brake/Rope Gripper is dropped. The main brake will stay energized for roughly 5 to 6 seconds.
  - i. After the test is complete the car will delay a few seconds and then attempt to recover to a floor.
  - j. Place the car on inspection and then remove all temporary connections.
  - k. Return the car to automatic and allow it to recover to a floor.

### 8.6.3 Test Ascending Car Overspeed Detection From Main Processor

---

- 4) To perform an over-speed test on the Main processor.
  - a. With the car on automatic, run the car to the bottom floor.
  - b. Select "Adjustable Variables -> Car Motion -> Overspeed Trip". Set this parameter to 80%.
  - c. Make a run to the top floor.

- d. When the car reaches 80% of contract speed, it will do an emergency stop dropping the Gripper/Emergency brake.
- e. Readjust the “Overspeed Trip” parameter to 115%.
- f. From the controller’s LCD display, select “Reset / View Faults -> Reset Gripper/EBK Fault” and follow the instructions displayed to reset the Gripper/Emergency brake.

## 8.7 Unintended Movement

---

The Safety processor will, independent of the Main processor, detect unintended car movement away from the landing with an open door circuit. Detection means meet the requirements of 2.19.2.2(a)(1)(b).

The Main processor will, independent of the Safety processor, detect unintended car movement away from the landing with an open door circuit. Detection means meet the requirements of 2.19.2.2(a)(1)(b).

### 8.7.1 Test Unintended Movement

---

- 1) With 125% load, place the elevator at the second landing, level with the floor and the front doors open on inspection. Make sure that someone is outside the elevator at the floor to ensure that no one enters the elevator during this test. Mechanically or electrically pick the Service Brake. To pick the brake electrically:
  - a. Put the BRK test switch in the test position.
  - b. Put the RUN test switch in the test position.
  - c. From the LCD display, select “Elevator Setup”, “Lift Brake On Inspect” and follow the instructions displayed to override the “Car Not Safe” status and lift the brake on inspection.
  - d. Push and hold the ENTER and UP button. This will cause the elevator to roll down with the doors open.
  - e. Verify that the Rope Gripper or Emergency Brake activates and stops the car.

To put the car back in service:

- a. Put the BRK test switch in the NORM position.
- b. Put the RUN test switch in the NORM position.
- c. From the LCD display, select “Reset / View Faults -> Reset Gripper/EBK Fault” and follow the instructions displayed to reset the Gripper/Emergency brake.
- d. Place the car back on automatic operation.

**Note: Repeat the above test procedure (8.8) for all modes of inspection operation applicable.**

## 8.8 Speed Control on Inspection

---

The Safety Processor and Safety PAL independent of the Main processor, verifies the speed of the car on inspection and removes power from the driving machine and brake if a fault condition is detected.

### 8.8.1 Check Inspection Speed Limit

---

- 1) Place the car on inspection.

- 2) From the LCD display interface, change the “Adjustable Variables -> Car Motion -> Insp Speed” parameter to 50fpm.
- 3) Change the “Safety Proc Adj Vars -> Insp Velocity” parameter to 25 fpm.
- 4) Run the elevator on inspection and verify the car comes to an immediate stop when the car exceeds 25 fpm. Observe that the SAF-PAL FAULT and SAF-PROC FAULT LEDs will come on for 2 seconds.
- 5) Change the “Insp Velocity” Parameter back to its original setting.
- 6) Return the car to automatic operation.

## 8.9 Speed Control on Access

---

The Safety processor and Safety PAL, independent of the Main processor, verifies the speed of the car on Access and removes power from the driving machine and brake if a fault condition is detected.

### 8.9.1 Test Access Speed Limit

---

- 1) Place the car on inspection.
- 2) From the LCD display interface, change the “Adjustable Variables -> Car Motion -> Access Speed” parameter to 50fpm.
- 3) Change the “Safety Proc Adj Vars -> Insp Velocity” parameter to 25 fpm.
- 4) Run the elevator on Access and verify the car comes to an immediate stop when the car exceeds 25 fpm. Observe that the SAF-PAL FAULT and SAF-PROC FAULT LEDs will come on for 2 seconds.
- 5) Change the “Access Speed” and “Insp Velocity” Parameters back to the original setting.
- 6) Return the car to automatic operation.

## 8.10 Speed in Leveling / Truck Zone

---

The Safety processor and Safety PAL, independent of the Main processor, verifies the speed of the car while in the leveling/truck zone and removes power from the driving machine and brake if a fault condition is detected.

### 8.10.1 Test Leveling Speed Limit

---

- 1) With the car in automatic operation.
- 2) From the LCD display interface, change the “Adjustable Variables -> Car Option -> Preopen Doors” parameter to 1 (enable preopening).
- 3) Change the “Safety Proc Adj Vars -> Leveling Vel” parameter to 0 fpm.
- 4) Place a call to an onward floor.
- 5) Verify that the car comes to an immediate stop when the car reaches the leveling zone at the destination floor and begins opening the door. Observe that the SAF-PAL FAULT and SAF-PROC FAULT LEDs will turn on. After the SAF-PAL FAULT and SAF-PROC FAULT LEDs go off, the car will then level into the floor.
- 6) Change the “Preopen Doors” and “Leveling Velocity” parameter back to the original setting.

## 8.11 Inner Landing Zone Limits

---

The Safety processor and Safety PAL, independent of the Main processor, verifies the inner landing zone and door status and removes power from the driving machine and brake if a fault condition is detected.

The Main processor is programmed to not attempt to run the car when outside of the inner landing zone until the doors are fully closed.

### 8.11.1 Test Inner Landing Zone Limits

---

- 1) Run the elevator to the top floor.
  - a. Run the elevator down, on inspection, outside the 3 inch door zone.
  - b. Open the doors.
  - c. Place the elevator on automatic service.
  - d. Verify that the car will not move until the doors close.
- 2) Run the elevator to a middle floor.
  - a. Run the elevator, on inspection, outside the 3 inch door zone.
  - b. Open the doors.
  - c. Place the elevator on automatic service.
  - d. Verify that the car will not move until the doors close.
- 3) Run the elevator to the bottom floor.
  - a. Run the elevator up, on inspection, outside the 3 inch door zone.
  - b. Open the doors.
  - c. Place the elevator on automatic service.
  - d. Verify that the car will not move until the doors close.
- 4) If the elevator has rear doors run the elevator to the rear opening.
  - a. Run the elevator on inspection outside the 3 inch door zone.
  - b. Open the rear doors.
  - c. Place the elevator on automatic service.
  - d. Verify that the car will not move until the rear doors close.

## 8.12 Protection Against Traction Loss

---

An encoder on the governor or a tape installed in the hoist-way will provide the velocity-measuring device for the suspension members and an encoder on the motor is used for the velocity measuring device for the drive sheave. The Safety Processor and the Main CPU will monitor each velocity device independently. If the difference between the velocity on the Safety Processor and the Main CPU is exceeded by a field adjustable amount (Adjustable Variables -> Car Options -> Slip Vel Diff), the system will engage the rope gripper or emergency brake, preventing the elevator from moving and a manual reset of the elevator controller needs to be performed.

### 8.12.1 Test Protection Against Traction Loss

---

To test the functionality of this operation, set the velocity check parameter to a lower value than normal and then run the car to verify that the gripper/emergency brake trips. This test can be accomplished using the following steps.

- 1) Under “Adjustable Variables -> Safety Processor Adjustable Variables” change the “Encoder RPM” to a value 50f/min lower than the existing value.
- 2) Under “Adjustable Variables -> Car Options”, set “Slip Vel Diff” parameter to 10f/min. With the car on automatic at the top or bottom landing, place a car call.
- 3) When the velocity difference between the Main CPU and the Safety Processor is greater than the “Slip Vel Diff” parameter value, a fault will be detected. Observe that the GR1 and the GR2 relays de-energize and the Rope Gripper or Emergency Brake sets.
- 4) To restore the car to normal operation, place the car on inspection. From the LCD display, select “Reset / View Faults -> Reset Gripper/EBK Fault” and follow the instructions displayed to reset the Gripper/Emergency brake.
- 5) Under “Adjustable Variables -> Car Options”, set “Slip Vel Diff” parameter back to its original value.
- 6) Under “Adjustable Variables -> Safety Processor Adjustable Variables” set the “Encoder RPM” parameter back to its original value.

---

## 8.13 Emergency Power

---

### 8.13.1 Test Emergency Power

---

- 1) Where applicable, simulate emergency power by installing a temporary connection from terminal HCP to terminal EMP. Make sure that the elevator(s) complies with 2.27.2.
- 2) To restore to normal operation, remove the temporary connection from terminal HCP to terminal EMP.

---

### 8.13.2 Power Loss Brake Lift

---

#### Contactors:

MBP – Manual Brake Power

MBC – Manual Brake Contactor

BRK – Brake Contactor

RUN – Run Contactor

MBC and MC are mechanically interlocked, mutually exclusive.

---

### 8.13.3 Test MBC Contactor

---

- 1) Before the car leaves the floor for a run in either direction, hold in the MBC contactor.
- 2) Place a call to another landing.
- 3) Observe that the car shuts down at the landing and does not restart.
- 4) To restore the car to normal operation, release the MBC contactor, move the controller inspection switch to the INS position and then back to NORM.

---

### 8.13.4 Testing The Communication From The Controller To The UPS

---

- 1) Disconnect the UPS communication cable.
- 2) Place a car call and verify that the car is out of service and does not leave the floor. Elevator Status will indicate “PWL UPS Comm Fault”.
- 3) Connect the UPS communication cable and the elevator will resume back in service.

### 8.13.5 Testing The UPS Battery Capacity

---

- 1) Under Diagnostics, UPS Comm Status note what the battery capacity is.
- 2) Under Adjustable Variables, System Options, set the Low Bat Cap Lev parameter to a value above the battery capacity observed under Diagnostics, UPS Comm Status.
- 3) Verify that the elevator does not accept car calls and does not start. Elevator Status will indicate “PWR UPS Fault”.
- 4) Change the parameter for Low Bat Cap Lev back to its original value.

### 8.13.6 Procedure To Electrically Pick The Main And Emergency Brake

---

- 1) Make sure the controller is on machine room inspection.
- 2) Push and hold the Manual Brake Pick Enable button on the controller until the MBP relay picks.
- 3) Put the Normal Brake BRK test switch in the test position.
- 4) Put the Normal Brake RUN test switch in the test position.
- 5) Under the Setup menu on the LCD Interface, select the Power Loss Lift Bake option. Press and hold the UP and Enter buttons to pick the main and emergency brakes.
- 6) The leveling zone status, UL, DZ and DL LEDs indicate when you are at or near a floor. Car speed and direction are shown on the LCD display.
- 7) When the car reaches the desired position, release the UP and Enter buttons.
- 8) Place the Normal Brake BRK and RUN test switches back to the Normal position.

## 8.14 Buffer Test

---

- 1) Position the car in the middle of the hoistway.
- 2) For a Car buffer test, install temporary connections from DTS and ETS inputs on the 1102 board to S10. For a Counterweight buffer test, install temporary connections from UTS and ETS inputs on the 1102 board to S10.
- 3) From the Controller’s LCD display, select the “Elevator Setup” menu and then select “Car Buffer Test” or Counterweight Buffer Test”.
- 4) Follow the menu directions to place the car on inspection, turn off automatic door and turn on the Independent switch.
- 5) The test also cannot be started from a terminal landing. If the car is at a terminal landing, the LCD display will show “To position the car press Enter”. Pressing “Enter” will place a car call at the appropriate position in the hoistway. If the car is already positioned properly for the run, the display will give the option to position the car or the skip to the next step.
- 6) Once the car is located in the correct starting position, select “Run Buffer Test”. When the “Enter” button is pressed, the car’s position will be modified internally to the top of the hoistway for a car buffer test or to the bottom of the hoistway for a counterweight buffer test. The car will then run high speed to the appropriate buffer.
- 7) While the car is in motion, the LCD display will change to “Press Enter Button to Cancel Buffer Test”. Pressing the “Enter” button will cause the car to execute an emergency slowdown.
- 8) After the test is complete, place the car on inspection.
- 9) Remove all temporary connections from UTS, DTS and ETS inputs on the 1102 board to S10.
- 10) Inspect the buffers and verify that the buffers function properly.
- 11) Verify proper operation of the elevator.